Fleetguard®



Air Filtration

LT36500



Why an Air Filtration System is So Important	5-5	DF1800 Series	5-106
Air Cleaner Housings	5-6	AH55576 • AH55674	5-106
How to Select an Air Cleaner	5-7	AH55577 • AH55675	5-108
Air Cleaner Selection Charts	5-8	AH55589 • AH55673	5-110
Air Filtration Application Guidelines	5-10	AH55590 • AH55672	5-112
Direct Flow™ Air Cleaners	5-13	DF2100 Series	5-114
DF200 Series	5-14	AH55661	5-114
AH55639	5-14	AH55662	5-116
AH55654	5-16	AH55663	5-118
AK55708	5-18	AH55664	5-120
AK55709	5-20	AH55665	5-122
AK55710	5-22	AH55666	5-124
AK55720	5-24	AH55668	5-126
DF390 TBAP Series	5-26	How to Service a Direct Flow™ System	5-128
AK55692	5-26	Frequently Asked Questions	5-129
AK55693	5-28	OptiAir™ Air Cleaners	5-131
AK55694	5-30	OptiAir™ 400 Series	5-132
AK55695	5-32	90° Outlet	5-134
AH55641	5-34	OptiAir™ 500 Series	5-136
AH55642	5-36	Straight Outlet	5-136
DF390 MAF Series	5-38	90° Outlet	5-138
AH55579	5-38	OptiAir™ 600 Series	5-140
AH55582	5-40	90° Outlet	5-142
AH55583	5-42	OptiAir™ 800 Series	5-144
AH55592	5-44	Straight Outlet	5-144
AK55681	5-46	90° Outlet	5-146
AK55682	5-48	OptiAir™ 1000 Series	5-148
DF585 MAF Series	5-50	Straight Outlet	5-148
AH55593	5-50	OptiAir™ 1100 Series	5-150
AH55584	5-52	Straight Outlet	5-150
AK55683	5-54	OptiAir™ 1300 Series	5-152
AK55684	5-56	Straight Outlet	5-152
AH55587	5-58	Straight Inlet	5-154
AH55588	5-60	OptiAir™ 1400 Series	5-156
DF585 TBAP Series	5-62	Hybrid	5-156
AH55643	5-62	How to Service an OptiAir™ System	5-158
AH55644	5-64	Metal Air Cleaners	5-161
AK55696	5-66	Service Parts	5-162
AK55697	5-68	Style 1	5-162
AK55698	5-70	Style 2	5-162
AK55699	5-72	Style 3	5-162
DF600 Series	5-74	AH19107	5-164
AH55508 • AH55555	5-74	AH19108	5-166
AH55598 • AH55602	5-76	AH19109	5-168
AH55600 • AH55604	5-78	AH19110	5-170
AH55599 • AH55603	5-80	AH19061 • AH19062	5-172
AH55601 • AH55605	5-82	AH19063 • AH19064	5-174
DF900 Series	5-84	AH19065 • AH19066	5-176
AH55542 • AH55559	5-84	AH19268	5-178
AH55543 • AH55556	5-86	AH19270 • AH19269	5-180
AH55544 • AH55560	5-88	AH19069 • AH19070	5-182
AH55545 • AH55557	5-90	AH19271 • AH19272	5-184
AH55548 • AH55561	5-92	AH19259	5-186
AH55549 • AH55558	5-94	AH19073 • AH19074	5-188
DF1200 Series	5-96	AH19075 • AH19076	5-190
AH55546 • AH55562	5-96	AH19077	5-192
AH55547 • AH55563	5-98	AH19078	5-194
AH55550 • AH55564	5-100	AH19079	5-196
AH55676 • AH55677	5-102	AH19080	5-198
AH55722 • AH55723	5-104	AH19473	5-200

Disposable Air Cleaners	5-203
Throw-Away Style • ECB Style	5-204
ECC Style • ECD Style	5-205
ECO II	5-206
ECO-SE	5-207
Air Intake Components	5-209
Hump Hoses/Hump Hose Reducers	5-209
Weather Hoods	5-210
Mounting Brackets	5-211
Hose Clamps • Dust Ejection Valves	5-212
Elbows	5-213
Reducing Elbows	5-214
Reducer Inlet Sleeves	5-215
Restriction Indicators	5-217
Pre-Cleaners	5-219
Maintenance Free	5-220
Radial Fin	5-290
Accessories	5-296
Aspiration System	5-299
Service and Maintenance Tips	5-301
Cleaning Air Filters	5-303
Revisions	5-305

Why an Air Filtration System is So Important



There Is Something In the Air

Air is not only vital for any life form on earth but also important for today's state of the art diesel engines. An average Heavy Duty Diesel truck engine requires between 3,650 to 5,600 gallons (13,000 to 20,000 liters) of air to burn just one liter of fuel. However, this air is polluted with all kinds of contaminants, such as fumes, dust, smog and other particles. Like temperature and humidity, these particles are not always visible to the eye, but they are harmful to the engine. They diminish the purity of the air and can lead to severe damage of all engine components. Under normal highway conditions, the air consumed by a 16 liter engine contains almost 20 kilograms of dirt/contaminants per 62,500 miles (100,000 kilometers).

Don't Compromise On Air Filtration

There is no room for compromise. The air intake is an open loop system, and the air filter only has one opportunity to filter the contaminant out of the intake air. Air filters are essential for heavy duty diesel engines, and the air that these engines 'breathe' needs to be as clean as possible. Poor air quality will significantly impact the performance of a diesel engine. Plugged air filters reduce engine performance, create higher fuel consumption, increase exhaust fumes and are harmful to the environment. Fleetguard® air filters are engineered to deliver optimized air quality and provide the best overall performance and service life. To properly perform its function of reducing wear and extending engine life, the air filter must filter 100% of the pre-combustion air and remove as much contaminant of any and every particle size as it can to a very high final efficiency. Sooner or later, the choice of the right filter for the right application can make a substantial difference in wear rate, cost and performance of your diesel engine.



From Pre-Cleaning to Direct Flow™

With a range of over 1,500 different air filtration products from clamps to air housings to "state-of-the-art" air filters, Fleetguard Heavy Duty Air Filtration, covers all the needs for your sophisticated air intake systems. Fleetguard Pre-Cleaners and highly efficient



Fleetguard pre-cleaner™ self cleaning Pre-cleaners are strongly recommended for construction, mining, farming, forestry and other segments where operating conditions are severe. For best preventive maintenance practice and to automatically monitor the performance of your air filter, use Fleetguard Restriction indicators. Fleetguard products are engineered to provide the best overall performance and service life. They are the ideal solution in terms of better engine protection, extended service intervals and lower maintenance cost. Our media technology is designed to meet technical specifications including fiber size, shape, pore size, paper thickness and mechanical strength. Fleetguard LIPS (Lenticular Integral Pleat Spacing) ensures that pleats are evenly spaced and that the air spreads equally throughout the surface to maximize filter capacity and life. Special resins impregnated in the media provide maximum performance. Hot melt bonding ensures proper alignment

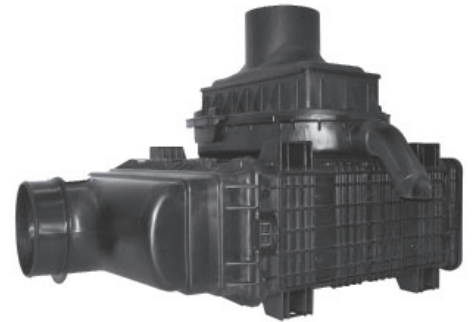

and protection of pleats throughout filter life.

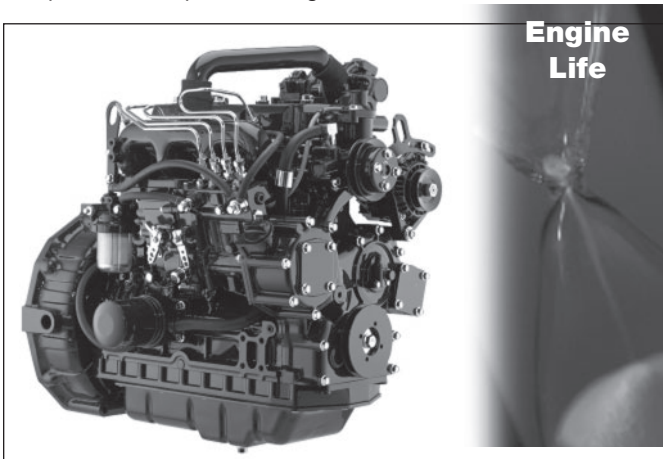

Air Cleaner Housings

Fleetguard® air housings, air cleaners and intake components meet the needs of over 200 Original Equipment Manufacturers (OEM). Fleetguard leads the way in air filtration technology through state-of-the-art design and manufacturing capabilities worldwide. We have the experience and technical expertise to design air filtration systems that exceed application requirements and maximize system potential.

Fleetguard manufacturing facilities around the world produce air filtration systems and are QS 9000, ISO 9001 and/or TS16949 certified. All performance data displayed in this section is based on ISO 5011/SAE J726 standards.



- Fleetguard products are used in a wide variety of markets, including:
- On-Highway - Heavy and Medium Duty Trucks
- Construction and Mining
- Agriculture
- Marine
- Industrial



Determine the Requirements

- Establish the air flow required
 - Refer to engine data sheet or contact engine manufacturer
 - Calculate from the available engine data using the formula below
- Establish the maximum allowable initial restriction
 - Refer to engine data sheet or contact engine manufacturer
 - If no information is available, use the 152 mm H₂O, 1.5 kPa, or 6 in H₂O rule of thumb as a guide for On-Highway applications and 254 mm H₂O, 2.5 kPa, or 10 in H₂O for Off-Highway/Industrial applications

Determine the Class of Air Cleaner: If in doubt always over-specify

- In what type of application/ environment will it operate?
 - Light dust concentration environment (single stage air cleaner)
 - On highway, Marine, Light dust environments
 - Medium dust concentration environment (2 stage air cleaner)
 - On/off highway, industrial with moderate dust
 - Heavy dust concentration environment (2 stage air cleaner with safety element)
 - Off road, industrial equipment with heavy dust in the air

Select an Appropriate Air Cleaner

- Examine the flow versus restriction curves to determine the restriction at your given flow rate
- Check the dimensional data to ensure it will fit the customer's application
- Verify that the capacity meets the performance requirements
- Inlet and outlet size and positioning

Determine the Accessories Needed

- Mounting Bracket(s)
- Weather Hood
- Restriction Indicator
- Fleetguard Pre-Cleaner
- Rubber Elbows, Hump Hoses, Hose Clamps, etc.

Air Flow Calculation Formula

$$\text{Metric: Air flow in m}^3/\text{min} = \frac{\text{swept volume}^1 (\text{liters}) \times \text{speed}^2 \times \text{VE}^3 \times \text{PF}^4}{1000 \times \text{CF}}$$

¹ engine displacement in liters; ² maximum engine RPM; ³ Volumetric Efficiency; ⁴ Pulsation factor

$$\text{Imperial: Air flow in CFM} = \frac{\text{swept volume}^5 (\text{CID}) \times \text{speed}^2 \times \text{VE}^3 \times \text{PF}^4}{1728 \times \text{CF}}$$

⁵ engine displacement in **cubic inches**; ² maximum engine RPM; ³ Volumetric Efficiency; ⁴ Pulsation factor

Volumetric Efficiency (VE)

- VE = can be greater than >2 for very new engine designs
- VE = 1.3 to 1.8 for 4 stroke engine with turbocharger
- VE = 0.85 for 4 stroke engine that is naturally aspirated
- VE = 1.4 for 2 stroke (cycle) engine with Roots-Compressor (blower)
- VE = 1.9 for 2 stroke (cycle) engine with Turbocharger

Cycle Factor (CF)

- CF = 2 for a four stroke (cycle) engine
- CF = 1 for a 2 stroke (cycle) engine

Pulsation Factor (PF) - only applies to engines that are *both naturally aspirated and having 3 cylinders or less*

- PF = 2-2.1 if only 1 cylinder
- PF = 1.4-1 for two cylinders
- PF = 1.33 for three cylinders

Air Cleaner Selection Charts

OptiAir™ Air Cleaner Selection Chart

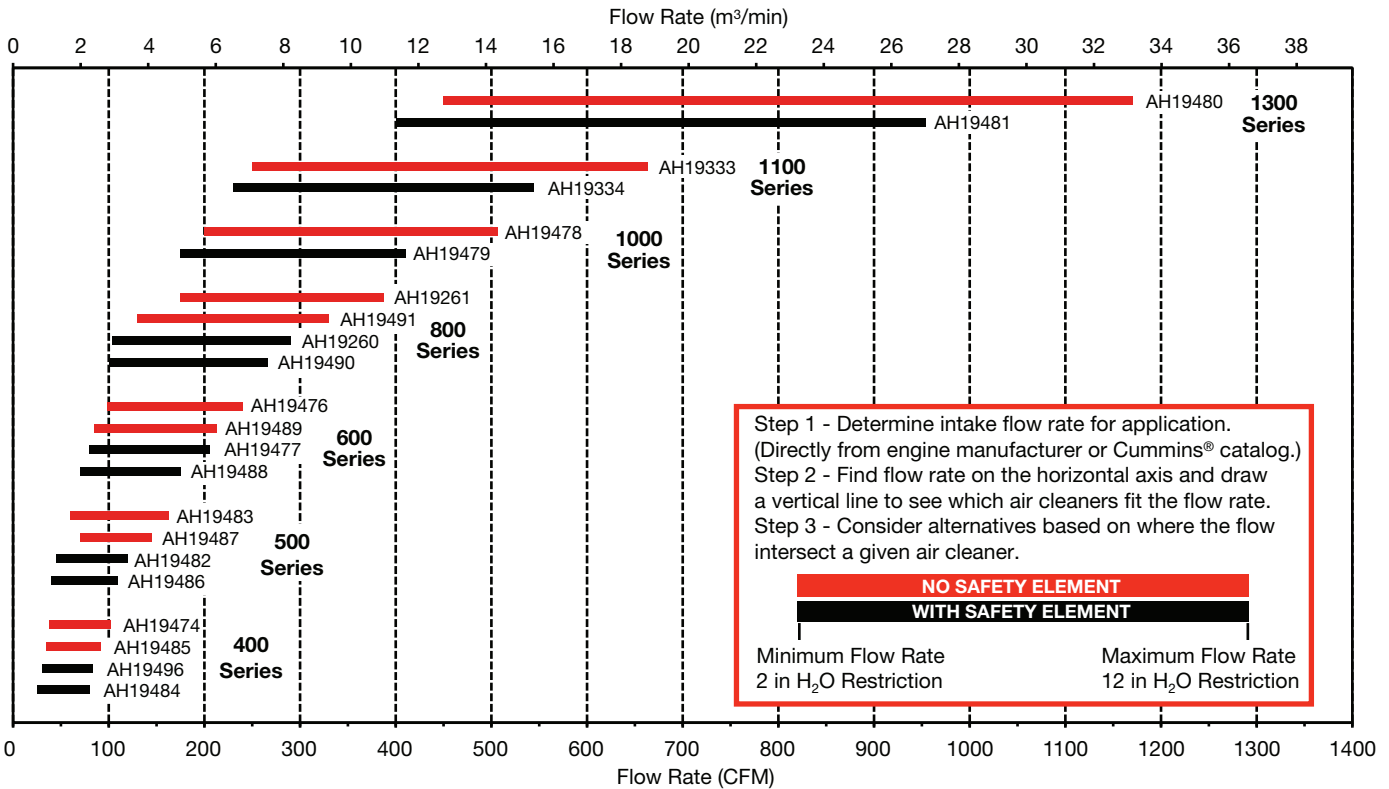

Metal Air Cleaner Selection Chart

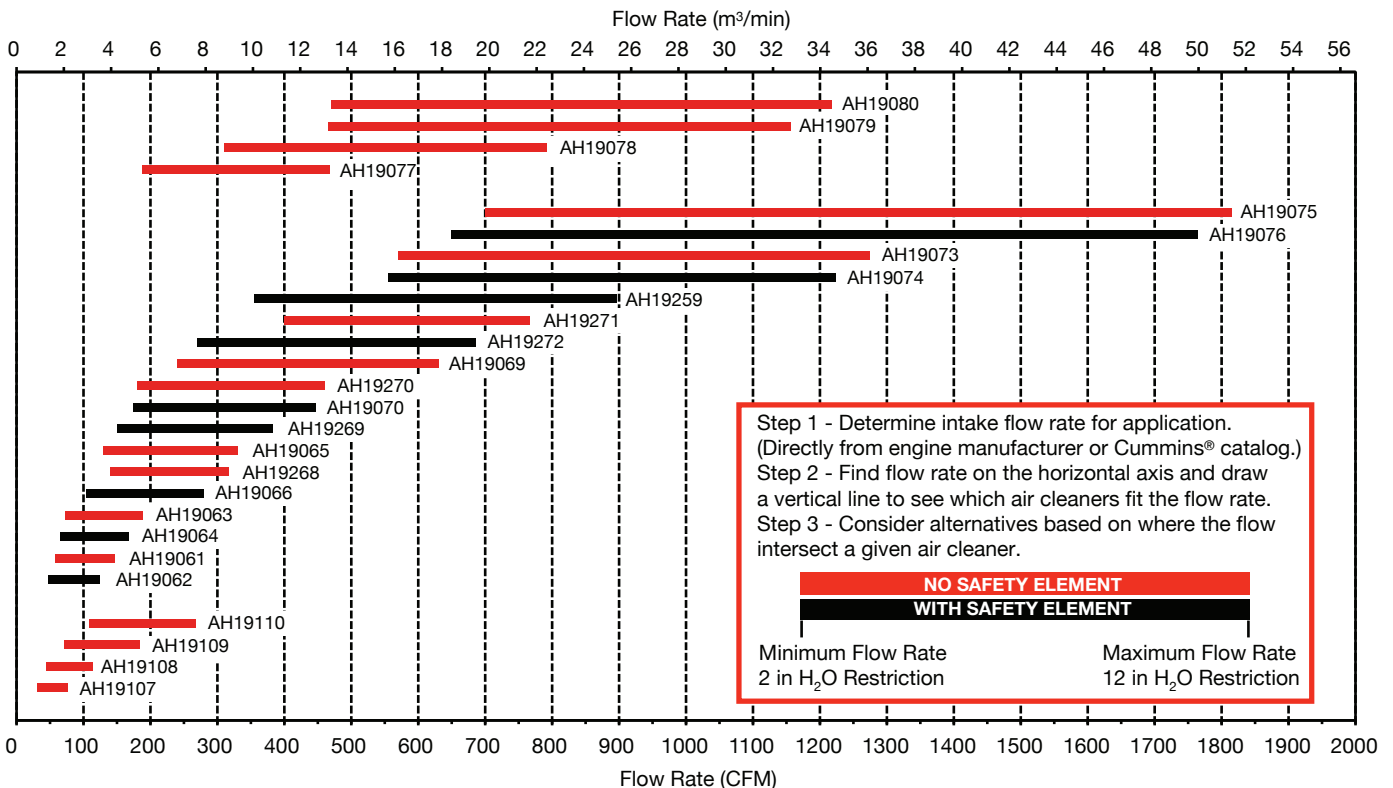

Direct Flow™ Flow Air Cleaner Selection Chart

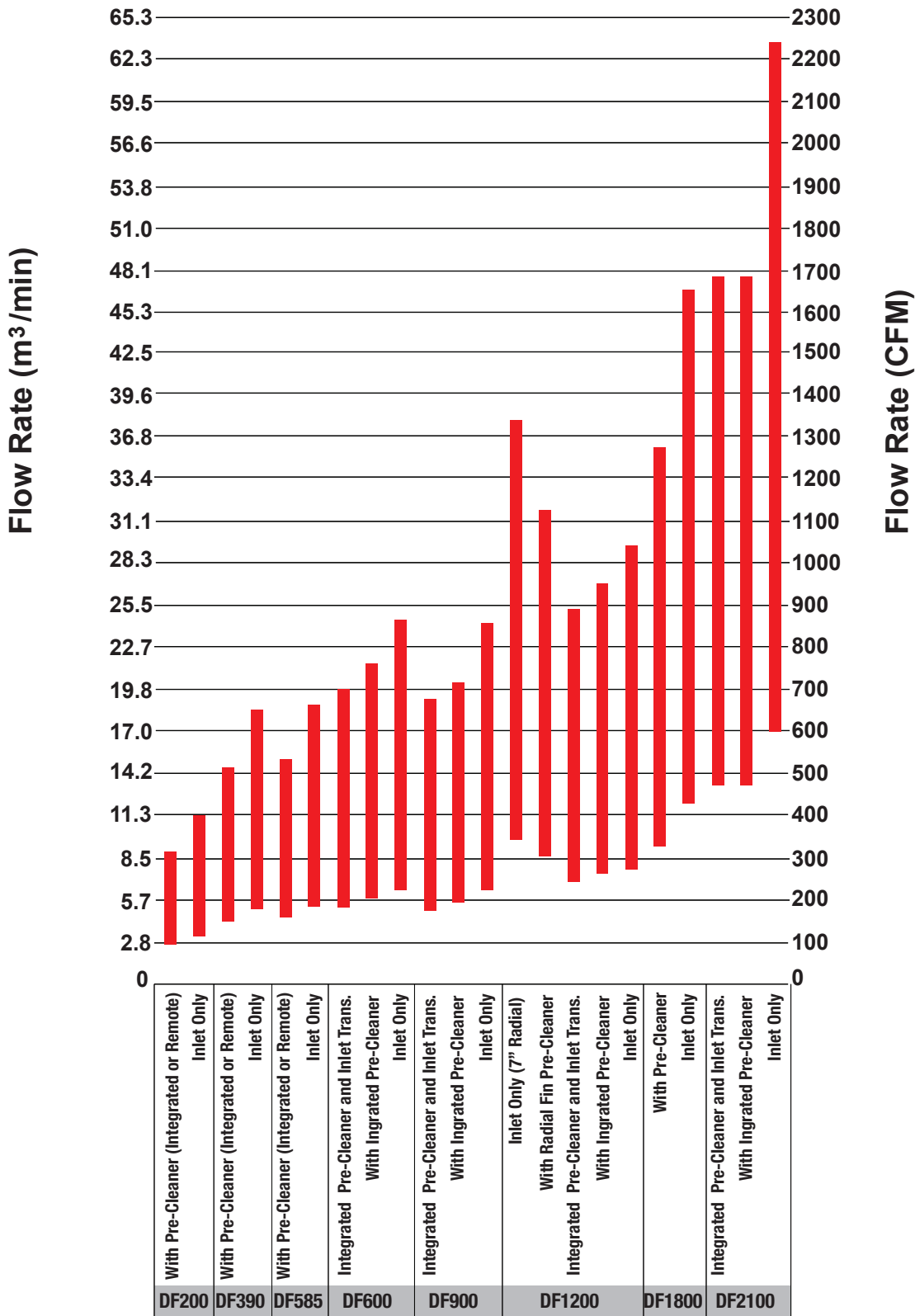

Air Filtration Application Guidelines

This section describes Air Filtration Application Guidelines as they relate to Engine Manufacturer Requirements, Environmental Considerations, and Durability.

Engine Manufacturer Requirements

System Restriction

Every engine manufacturer has their own recommendation for the maximum allowable initial (clean) restriction for the air intake system, which includes upstream and downstream ducting and grills. If the system's initial restriction requirements are unknown, use 3.74 kPa (15 in H₂O) for off-highway applications and 2.49 kPa (10 in H₂O) for on-highway applications.



This application is where ducting specifications are important. Pressure loss through the combination of upstream and downstream ducting is generally 0.75-1.25 kPa (3-5 in H₂O). However, poor ducting designs can more than double that effect. Proper duct design and care taken to minimize initial restriction will improve the air cleaner's capacity and **increase service life**.

The following are key items for minimizing pressure drop:

- Ensure that air intake openings are as large as possible. Utilize ideal openings or grills (where possible) to straighten the flow path at air intake openings.
- Minimize the number of turns and transitions and avoid sharp angles and rough surfaces.
- Keep the duct diameter as large as possible throughout the system and reduce down as close to the engine/turbo intake as possible.
- When combining two flows, use gradual "Y" angles. A gradual "Y" angle is preferred, as "T" style connections cause pressure loss due to turbulence.

Ducting Designs

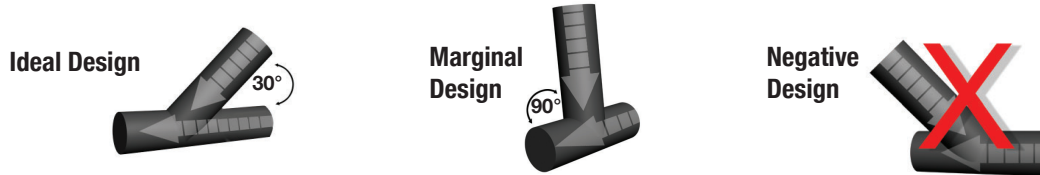

One way to describe dust holding capacity is by taking a ratio of the grams of dust processed by the air cleaner per engine airflow (g/CFM). The following dust holding capacities are recommended for the given dust environments:

Dust Holding Capacity

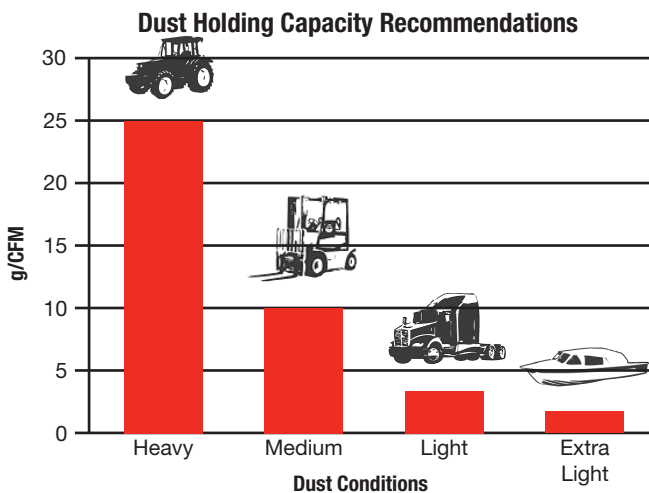

Dust Environments and Typical Applications

Heavy = Construction, mining, convoys on dirt roads, agricultural equipment

Medium = Asphalt equipment, forklifts

Light = On-highway vehicles in developed countries, lawn & turf equipment

Extra Light = Marine use, residential stationary equipment

For light environments the dust holding capacity can range from 1.5-3 g/CFM.

Heavy and medium dust environments require a two-stage air cleaner such as an integral pre-cleaner with a tangential inlet, or a spinner fin. Dump trucks and on-road trucks spending more than 20% of their time off-road or in developing countries should anticipate medium or heavy dust conditions. Heavy-duty applications should always utilize an air cleaner with a secondary element. The use of a secondary element is also recommended for medium-duty applications.

Air Filtration Application Guidelines

Environmental Considerations

The purpose of the air intake system is to provide clean, cool, quiet, and dry air for the engine. Keep the following environmental conditions in mind when positioning the air cleaner and intake ducting:

- **Protect the intake air from water ingestion by utilizing weather hoods or other protection.**
- **Position the air intake to minimize dust ingress.** Do not draw air from the wheel well or under carriage areas. The air intake should be positioned as high as possible and toward the front of the vehicle for on-highway vehicles. (Small variations in the air intake position can greatly improve service life.)
- **Air intake ducting should draw air from near-ambient locations.** Increased air intake temperatures have a significant effect on engine power.
- **Continuous Operating Temperature Range (COTR) for the plastic air cleaners shown in this catalog is -40 °F (-40 °C) to 180 °F (82 °C).** Heat shielding and air baffles are acceptable options for reducing skin temperatures. If higher temperature materials are required, contact your Fleetguard sales representative to inquire about custom designs (minimum quantities may apply).

Durability

Air cleaners should be chassis mounted to minimize vibration. Engine mounting is only recommended with proper validation by a vehicle/equipment designer. Avoid the mounting of air cleaners or other components to 3-cylinder engines, as the vibration level is excessive due to the natural unbalanced condition of the engine. If vibration is a concern, consider iso-mounting or bracket designs to reduce acceleration levels and move the air cleaner resonance points away from the engine or vehicle resonance frequencies. Consider both the engine and vehicle resonance points. Engine resonance frequencies can be easily calculated. Vehicle resonance points are not easy to calculate. However, many on-highway vehicles have their first resonance point at or around 20 Hz. For further assistance in dealing with vibration issues, contact your Fleetguard representative to inquire about custom designs or materials (minimum quantities may apply).

When air cleaners are chassis mounted, pay close attention to the clean side ducting design. Because of the relative movement between the air cleaner and the engine, the ducting will be exposed to additional forces and the hose design may need to compensate for significant length changes between connections during operation. Flexible hose connections are essential.

Minimize vibration with a chassis mount.

Protect the inlet from harmful elements with a weather hood.

Ensure that the design accounts for full relative motion between the air cleaner and the engine. Flexible connections are mandatory.

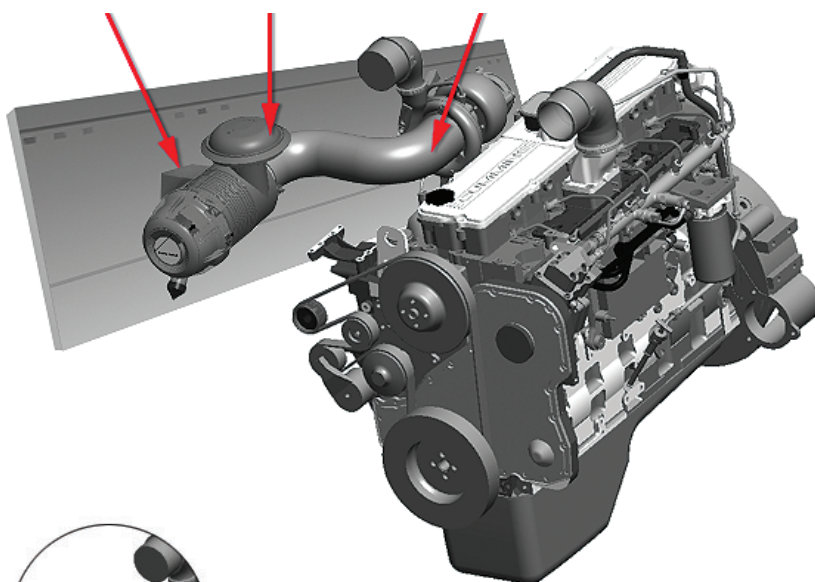

Avoid mounting in areas where ducting is exposed to components that could cause abrasive wear.

Miscellaneous Guidelines

- **Torque Range:** The torque range for plastic inlet/outlet tubes = 25-40 in-lbs (2.8-4.5 N·m). Do not over-torque connections.
- **Hose Connections:** Use appropriate hose connections. SAE HD Worm Gear F-style or T-bolt are recommended.
- **Connection Points:** Minimize the connection points. Leakage is a greater risk with multiple connections.
- **Hose Materials:** Utilize the appropriate high temperature material at the turbo.
- **Intake Routing:** Use caution when routing intake system ducting by avoiding damage from abrasion and heat sources.
- **Excessive Weight:** Avoid excessive unsupported weight on clamped joints (< 3 lb (1.4 kg) recommended).
- **Restriction Indicators:** Utilize restriction indicators in the system to monitor restriction and maximize performance and service life.

Direct Flow™ Air Cleaners

Reduced Volume - Improved Performance - Flexible Packaging

The patented Direct Flow technology provides the flexibility to optimize the air system performance to size ratio, meeting the demands of today's engines and specialized applications.

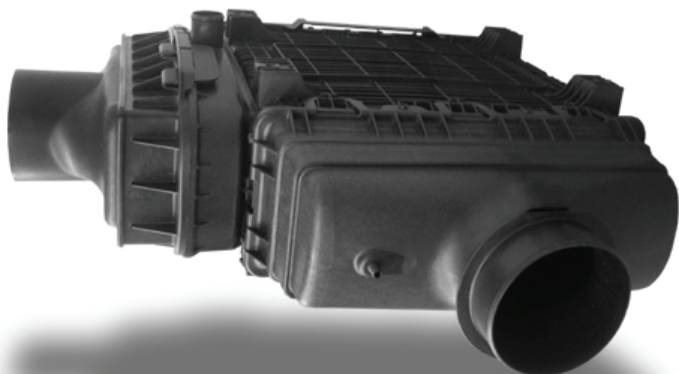

Direct Flow™ design utilizes more media volume in less space than some cylindrical systems

The Direct Flow Advantage

Front Inlet/Front Service

Air Out

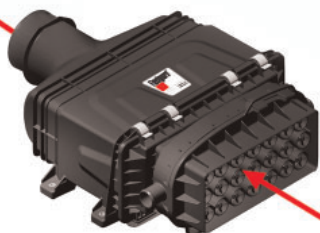

Air In

Integrated Handle
Improved serviceability

Element Label
Can display service part information and service instructions

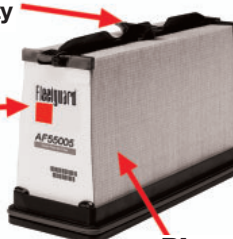

Phenolic Media
Water resistant with high stiffness to improve service intervals

Side Inlet/Front Service

Air In

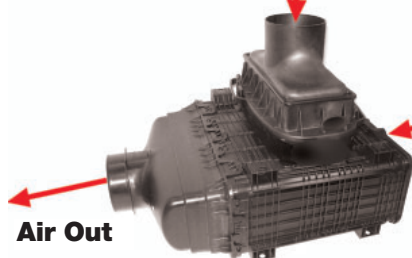

Service Element

Air Out



Metal-Free Service Element



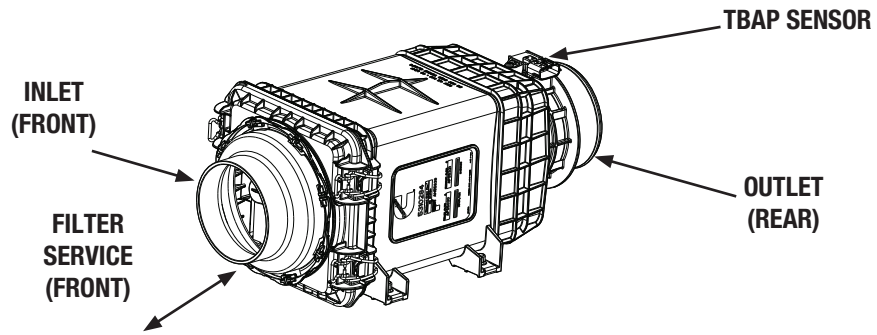

Specifications

Specification	AH55639
Length, Overall	16.9" (432.2 mm)
Width, Overall	8.1" (207.4 mm)
Height, Overall	7.2" (184.3 mm)
Flow, Min. at 2" H ₂ O (0.5 kPa) Restriction	110 CFM (3.1 m ³ /min)
Flow, Max. at 12" H ₂ O (3.0 kPa) Restriction	280 CFM (709 m ³ /min)
Secondary Element	Yes
Housing Material	Glass-filled Polyamide
Pre-Cleaner	No
Inlet	Straight, 4.05" (103.0 mm)
Outlet	Straight, 4.08" (103.7 mm)
Filter Efficiency	≥ 99.90% per ISO 5011

Specifications Subject to change without notice.

Dust Holding Capacity per Flow Rate

Specification	Non Aspirated	
	CFM	m ³ /min
Maximum Flow for 10 g/CFM (357.1 g/m ³ /min)	75	2.1
Maximum Flow for 25 g/CFM (892.9 g/m ³ /min)	*N/A	*N/A

*Requires Pre-Cleaner (Optional)

Dimensions

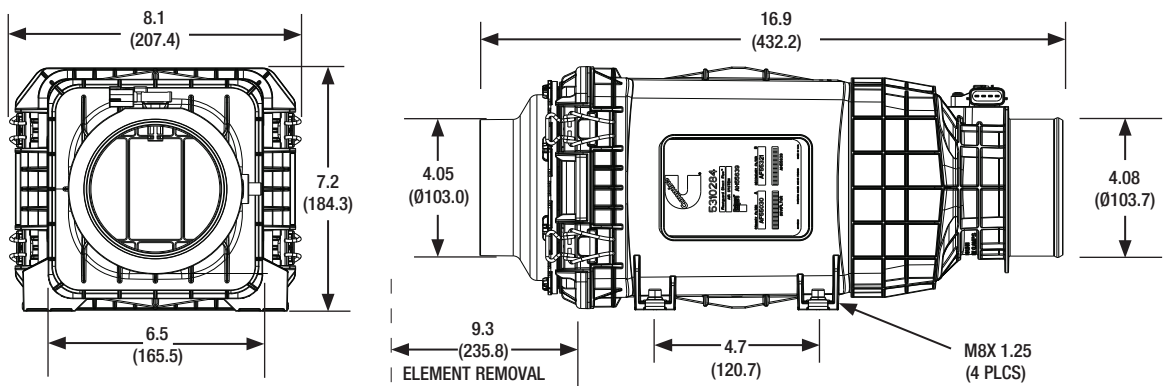

All dimensions are in inches (millimeters)

Ordering Information

Air Cleaners	
Part Number	Description
AH55639	Direct Flow -Front Inlet -With TBAP Sensor

Service Parts	
Part Number	Description
AF55030	Primary Element
AF55321	Secondary Element
SP1080	Front Service Cover

Optional Accessories	
Part Number	Description
3316658S	4" Band Clamp
3316660S	5" Band Clamp
3316608S	4" Hump Hose
3316610S	5" Hump Hose
3316568S	4" 90° Elbow
3316570S	5" 90° Elbow
3316618S	5" to 4" Hump Hose Reducer
3946329S	Restriction Indicator

Additional sizes/shapes may be available.
Refer to the Cummins Filtration catalog or website.

Performance

System Restriction vs Flow Rate

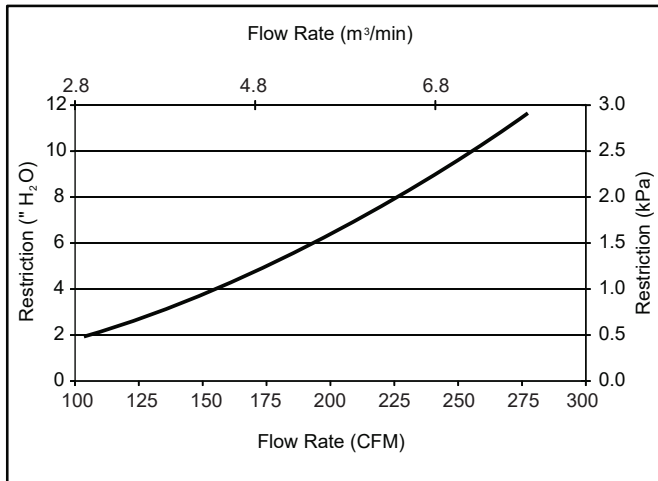

System Capacity vs Flow Rate

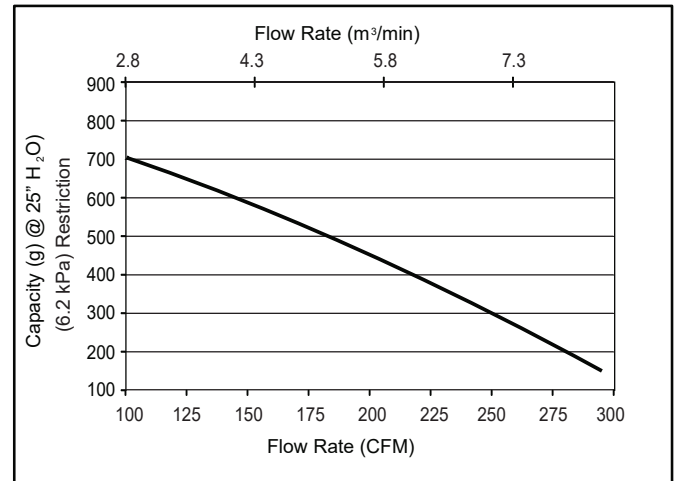

Restriction		Flow Rate		Typical Capacity at 25" H ₂ O (6.2 kPa) of Terminal Restriction
in H ₂ O	kPa	CFM	m³/min	Non Aspirated (g)
4	1.0	155	4.4	570
6	1.5	190	5.4	480
8	2.0	225	6.4	380
10	2.5	253	7.2	295
12	3.0	280	7.9	200

ISO Fine Dust
1.0 g/m³ Feed Rate
25" H₂O (6.2 kPa)
Terminal Restriction
per ISO 5011

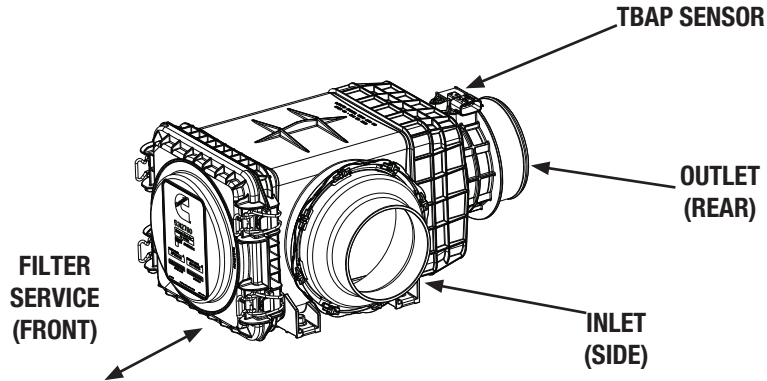

Specifications

Specification	AH55654
Length, Overall	15.1" (383.8 mm)
Width, Overall	10.2" (261.4 mm)
Height, Overall	7.2" (184.3 mm)
Flow, Min. at 2" H ₂ O (0.5 kPa) Restriction	110 CFM (3.1 m ³ /min)
Flow, Max. at 12" H ₂ O (3.0 kPa) Restriction	288 CFM (8.2 m ³ /min)
Secondary Element	Yes
Housing Material	Glass-filled Polyamide
Pre-Cleaner	No
Inlet	90° to Outlet 4.05" (103.0 mm)
Outlet	Straight 4.08" (103.7 mm)
Filter Efficiency	≥ 99.90% per ISO 5011

Specifications Subject to change without notice.

Dust Holding Capacity per Flow Rate

Specification	Non Aspirated	
	CFM	m ³ /min
Maximum Flow for 10 g/CFM (357.1 g/m ³ /min)	74	2.0
Maximum Flow for 25 g/CFM (892.9 g/m ³ /min)	N/A*	N/A*

*Requires Pre-cleaner (Optional)

Dimensions

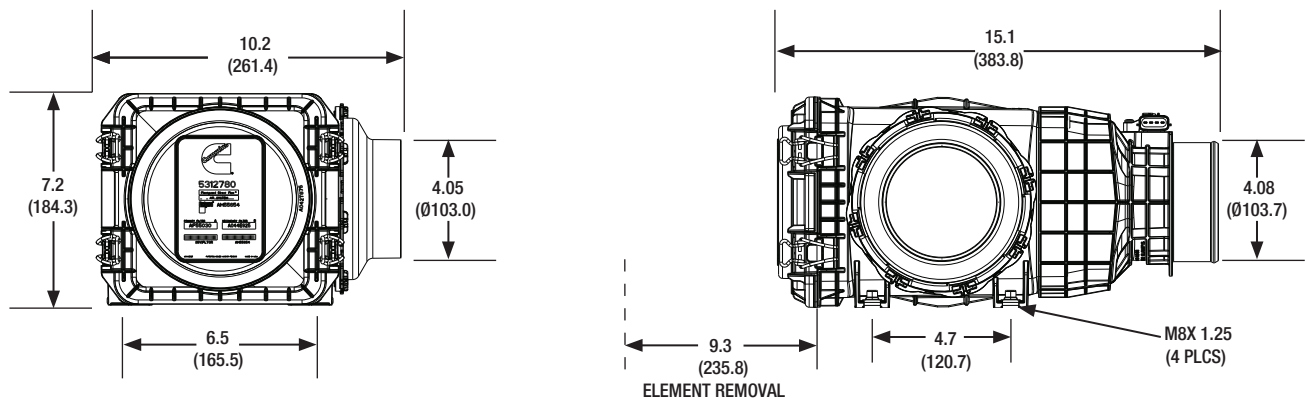

All dimensions are in inches (millimeters)

Ordering Information

Air Cleaners	
Part Number	Description
AH55654	Direct Flow -Side Inlet -With TBAP Sensor

Service Parts	
Part Number	Description
AF55030	Primary Element
AF55321	Secondary Element
SP1079	Front Service Cover

Optional Accessories	
Part Number	Description
3316658S	4" Band Clamp
3316660S	5" Band Clamp
3316608S	4" Hump Hose
3316610S	5" Hump Hose
3316568S	4" 90° Elbow
3316570S	5" 90° Elbow
3316618S	5" to 4" Hump Hose Reducer
3946329S	Restriction Indicator

Additional sizes/shapes may be available. Refer to the Cummins Filtration catalog or website.

Performance

System Restriction vs Flow Rate

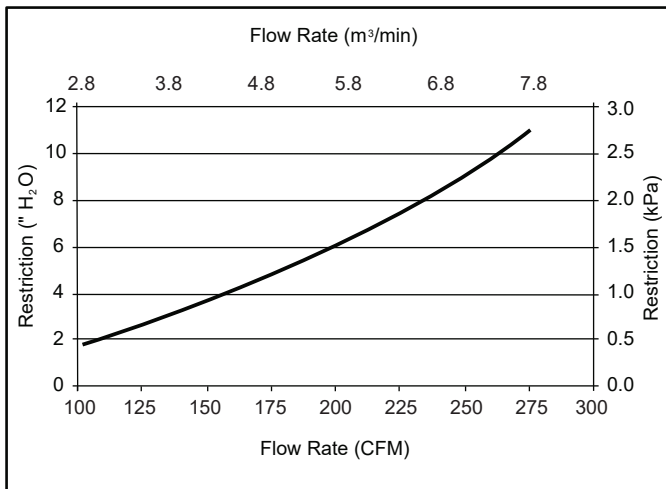

System Capacity vs Flow Rate

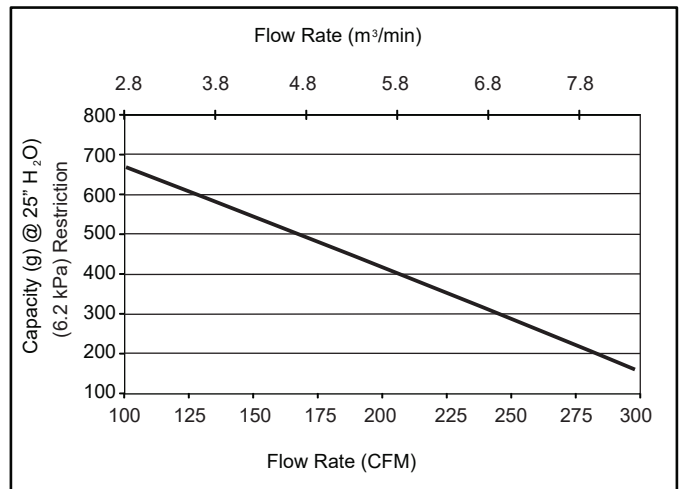

Restriction		Flow Rate		Typical Capacity at 25" H ₂ O (6.2 kPa) of Terminal Restriction
in H ₂ O	kPa	CFM	m³/min	Non Aspirated (g)
4	1.0	160	4.5	520
6	1.5	198	5.6	420
8	2.0	233	6.6	330
10	2.5	262	7.4	250
12	3.0	288	8.2	180

ISO Fine Dust
1.0 g/m³ Feed Rate
25" H₂O (6.2 kPa)
Terminal Restriction
per ISO 5011

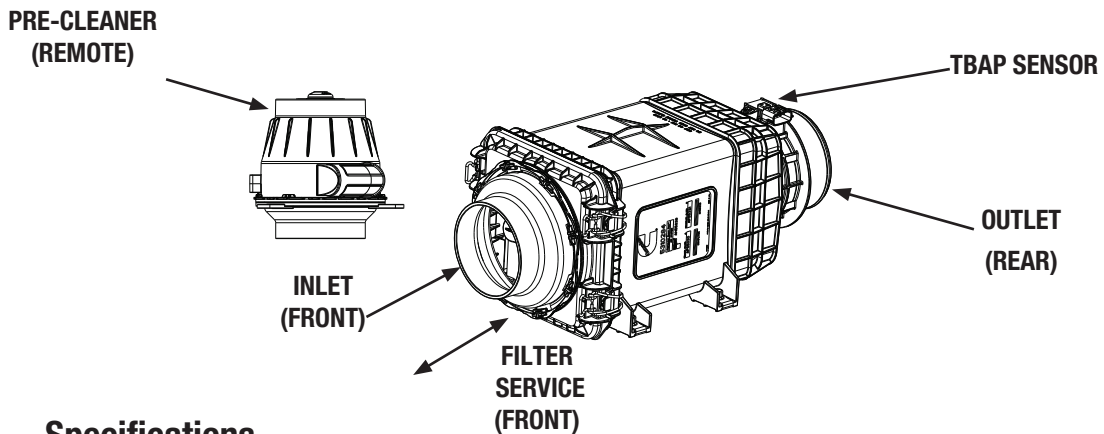

Specifications

Specification	AK55708
Length, Overall	16.9" (431.2 mm)
Width, Overall	8.1" (207.4 mm)
Height, Overall	7.2" (184.3 mm)
Flow, Min. at 2" H ₂ O (0.5 kPa) Restriction	90 CFM (3.5 m ³ /min)
Flow, Max. at 12" H ₂ O (3.0 kPa) Restriction	220 CFM (6.2 m ³ /min)
Secondary Element	Yes
Housing Material	Glass-filled Polyamide
Pre-Cleaner	Remote
Inlet	Straight 4.05" (103.0 mm)
Outlet	Straight 4.08" (103.7 mm)
Filter Efficiency	≥ 99.90% per ISO 5011

Specifications Subject to change without notice.

Dust Holding Capacity per Flow Rate

Specification	Non Aspirated	
	CFM	m ³ /min
Maximum Flow for 10 g/CFM (357.1 g/m ³ /min)	180	5.0
Maximum Flow for 25 g/CFM (892.9 g/m ³ /min)	102	2.8

Dimensions

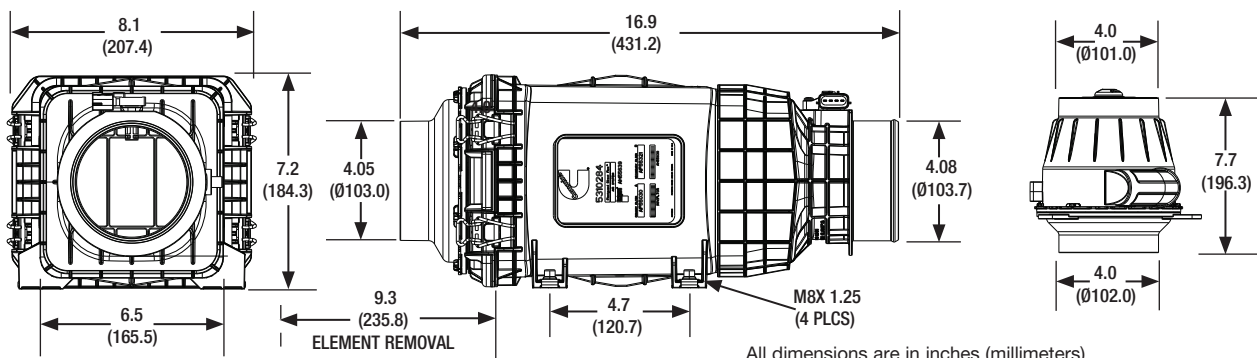

All dimensions are in inches (millimeters)

Ordering Information

Air Cleaners	
Part Number	Description
AK55708	Direct Flow -Front Inlet -Remote Mount Pre-Cleaner -With TBAP Sensor

Service Parts	
Part Number	Description
AF55030	Primary Element
AF55321	Secondary Element
AP15910	Pre-Cleaner
AP15911	Pre-Cleaner Remote Adapter
SP1080	Front Service Cover
SP1048	Dust Ejector Valve (DEV)

Optional Accessories	
Part Number	Description
3316658S	4" Band Clamp
3316660S	5" Band Clamp
3316608S	4" Hump Hose
3316610S	5" Hump Hose
3316568S	4" 90° Elbow
3316570S	5" 90° Elbow
3316618S	5" to 4" Hump Hose Reducer
3946329S	Restriction Indicator

Additional sizes/shapes may be available.
Refer to the Cummins Filtration catalog or website.

Performance

System Restriction vs Flow Rate

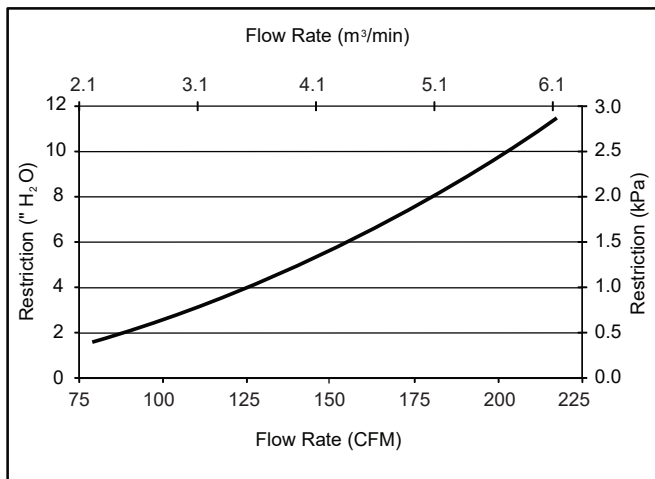

System Capacity vs Flow Rate

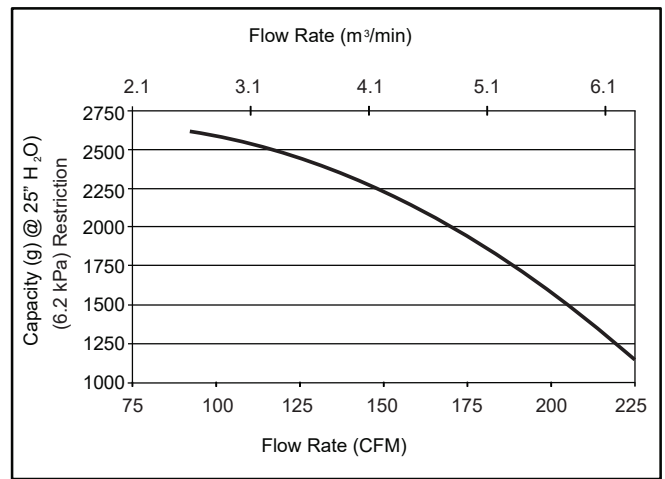

Restriction		Flow Rate		Typical Capacity at 25" H ₂ O (6.2 kPa) of Terminal Restriction
in H ₂ O	kPa	CFM	m³/min	Non Aspirated (g)
4	1.0	123	3.5	2325
6	1.5	160	4.5	2050
8	2.0	178	5.1	1825
10	2.5	200	5.7	1600
12	3.0	220	6.2	1450

ISO Coarse Dust
2.0 g/m³ Feed Rate
25" H₂O (6.2 kPa)
Terminal Restriction
per ISO 5011

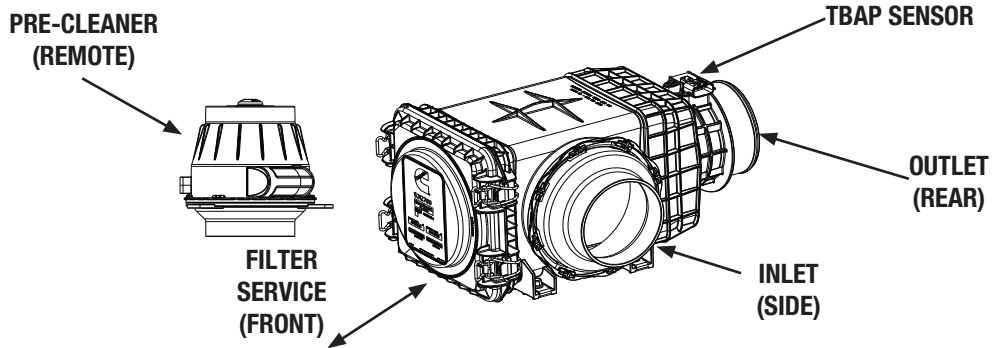

Specifications

Specification	AK55709
Length, Overall	15.1" (383.8 mm)
Width, Overall	10.2" (261.4 mm)
Height, Overall	7.2" (184.3 mm)
Flow, Min. at 2" H ₂ O (0.5 kPa) Restriction	90 CFM (3.5 m ³ /min)
Flow, Max. at 12" H ₂ O (3.0 kPa) Restriction	220 CFM (8.6 m ³ /min)
Secondary Element	Yes
Housing Material	Glass-filled Polyamide
Pre-Cleaner	Remote
Inlet	90° to Outlet 4.05" (103.0 mm)
Outlet	Straight 4.08" (103.7 mm)
Filter Efficiency	≥ 99.90% per ISO 5011

Specifications Subject to change without notice.

Dust Holding Capacity per Flow Rate

Specification	Non Aspirated	
	CFM	m ³ /min
Maximum Flow for 10 g/CFM (357.1 g/m ³ /min)	180	5.0
Maximum Flow for 25 g/CFM (892.9 g/m ³ /min)	102	2.8

Dimensions

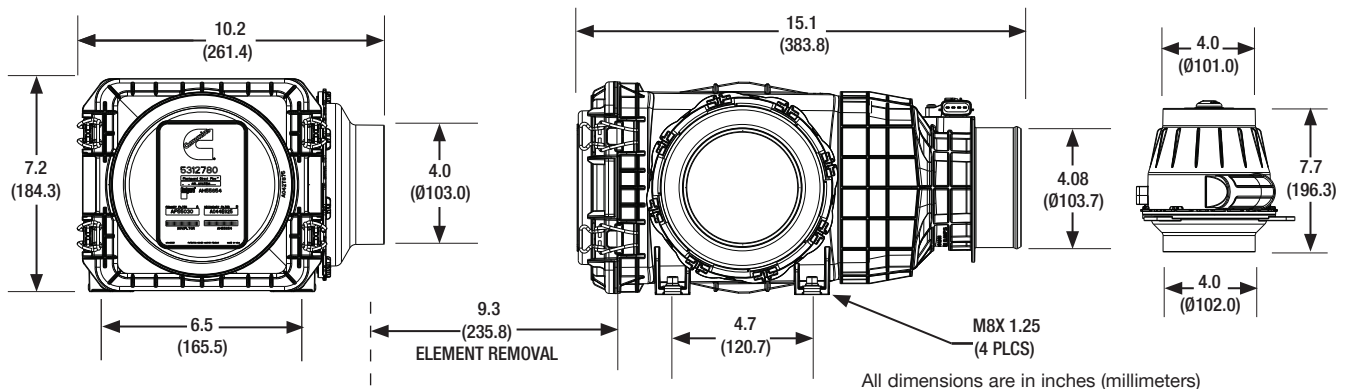

Ordering Information

Air Cleaners	
Part Number	Description
AK55709	Direct Flow -Side Inlet -Remote Mount Pre-Cleaner -With TBAP Sensor

Service Parts	
Part Number	Description
AF55030	Primary Element
AF55321	Secondary Element
SP1079	Front Service Cover
AP15910	Pre-Cleaner
AP15911	Pre-Cleaner Remote Adapter
SP1048	Dust Ejector Valve (DEV)

Optional Accessories	
Part Number	Description
3316658S	4" Band Clamp
3316660S	5" Band Clamp
3316608S	4" Hump Hose
3316610S	5" Hump Hose
3316568S	4" 90° Elbow
3316570S	5" 90° Elbow
3316618S	5" to 4" Hump Hose Reducer
3946329S	Restriction Indicator

Additional sizes/shapes may be available.
Refer to the Cummins Filtration catalog or website.

Performance

System Restriction vs Flow Rate

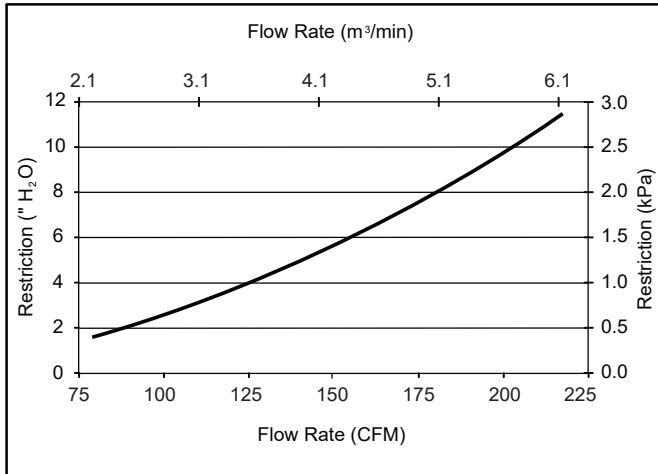

System Capacity vs Flow Rate

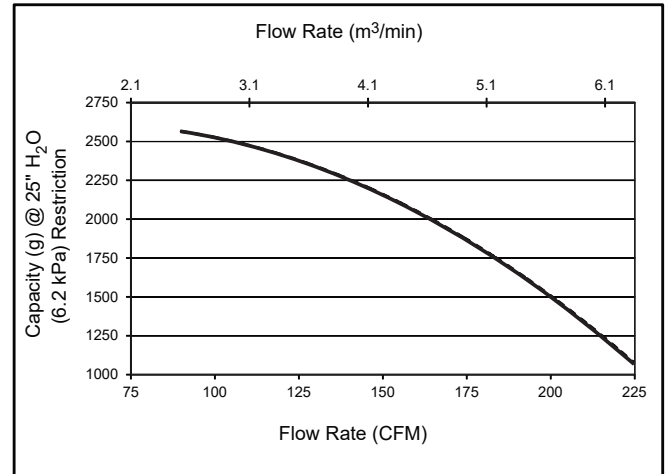

Restriction		Flow Rate		Typical Capacity at 25" H ₂ O (6.2 kPa) of Terminal Restriction
in H ₂ O	kPa	CFM	m³/min	Non Aspirated (g)
4	1.0	123	3.5	2400
6	1.5	160	4.5	2100
8	2.0	180	5.1	1800
10	2.5	202	5.7	1475
12	3.0	220	6.2	1250

ISO Coarse Dust
2.0 g/m³ Feed Rate
25" H₂O (6.2 kPa)
Terminal Restriction
per ISO 5011

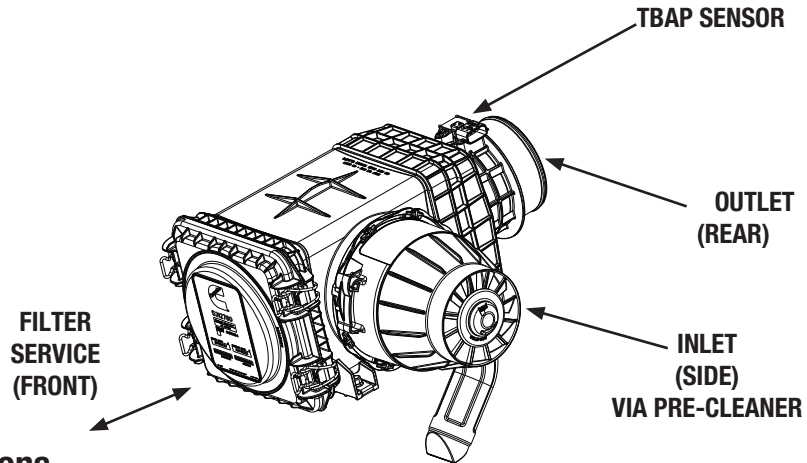

Specifications

Specification	AK55710
Length, Overall	15.1" (383.8 mm)
Width, Overall	13.9" (353.9 mm)
Height, Overall	7.2" (184.3 mm)
Flow, Min. at 2" H ₂ O (0.5 kPa) Restriction	90 CFM (3.5 m ³ /min)
Flow, Max. at 12" H ₂ O (3.0 kPa) Restriction	220 CFM (8.6 m ³ /min)
Secondary Element	Yes
Housing Material	Glass-filled Polyamide
Pre-Cleaner	Integrated
Inlet	90° to outlet 4.0" (103.0 mm)
Outlet	Straight 4.0" (103.0 mm)
Filter Efficiency	≥ 99.90% per ISO 5011

Specifications Subject to change without notice.

Dust Holding Capacity per Flow Rate

Specification	Non Aspirated	
	CFM	m ³ /min
Maximum Flow for 10 g/CFM (357.1 g/m ³ /min)	180	5.0
Maximum Flow for 25 g/CFM (892.9 g/m ³ /min)	102	2.8

Dimensions

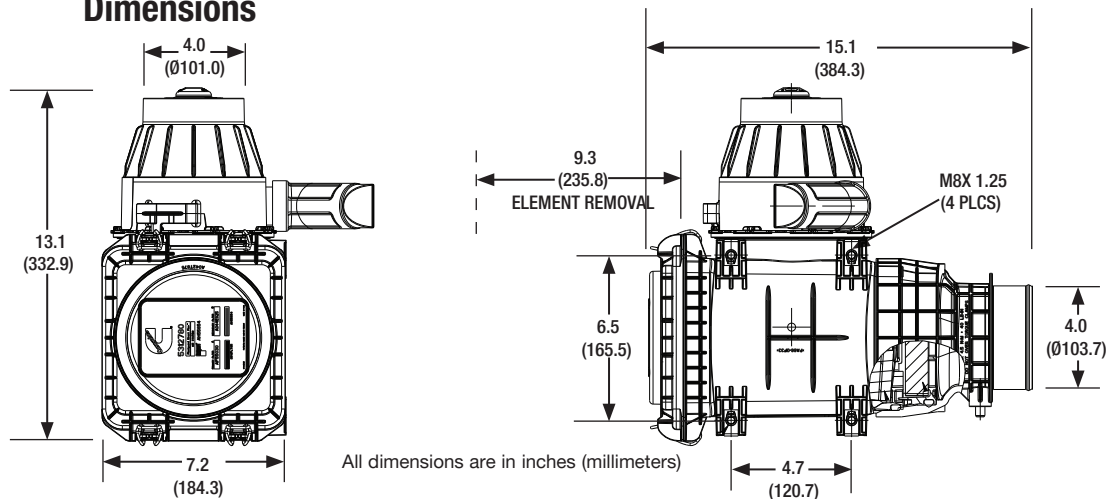

Ordering Information

Air Cleaners	
Part Number	Description
AK55710	Direct Flow -Side Inlet -Integrated Pre-Cleaner -With TBAP Sensor

Service Parts	
Part Number	Description
AF55030	Primary Element
AF55321	Secondary Element
AP15910	Pre-Cleaner
SP1079	Front Service Cover
SP1048	Dust Ejector Valve (DEV)

Optional Accessories	
Part Number	Description
3316658S	4" Band Clamp
3316660S	5" Band Clamp
3316608S	4" Hump Hose
3316610S	5" Hump Hose
3316568S	4" 90° Elbow
3316570S	5" 90° Elbow
3316618S	5" to 4" Hump Hose Reducer
3946329S	Restriction Indicator

Additional sizes/shapes may be available.
Refer to the Cummins Filtration catalog or website.

Performance

System Restriction vs Flow Rate

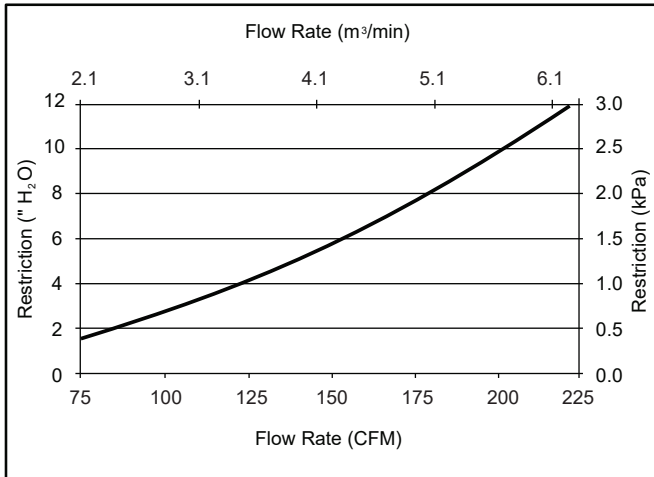

System Capacity vs Flow Rate

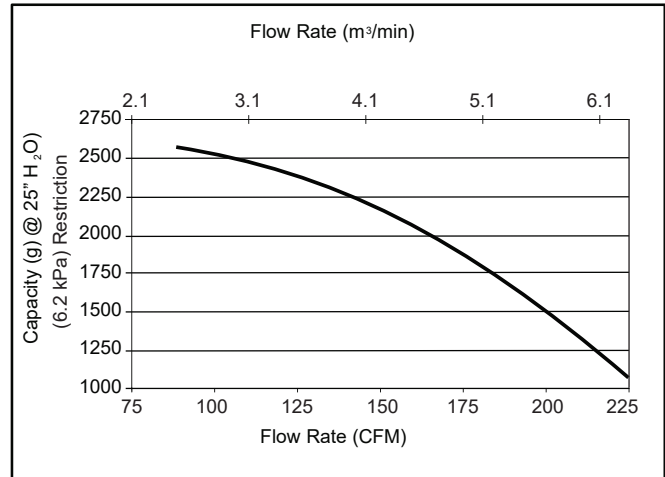

Restriction		Flow Rate		Typical Capacity at 25" H ₂ O (6.2 kPa) of Terminal Restriction
in H ₂ O	kPa	CFM	m³/min	Non Aspirated (g)
4	1.0	123	3.5	2400
6	1.5	160	4.5	2100
8	2.0	180	5.1	1800
10	2.5	202	5.7	1475
12	3.0	220	6.2	1250

ISO Coarse Dust
2.0 g/m³ Feed Rate
25" H₂O (6.2 kPa)
Terminal Restriction
per ISO 5011

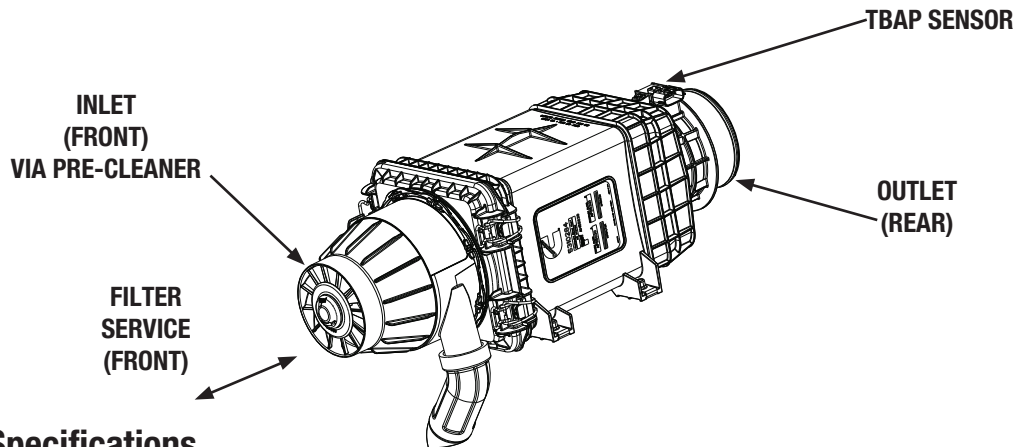

Specifications

Specification	AK55720
Length, Overall	20.5" (522.7 mm)
Width, Overall	8.1" (207.4 mm)
Height, Overall	7.2" (184.2 mm)
Flow, Min. at 2" H ₂ O (0.5 kPa) Restriction	90 CFM (3.5 m ³ /min)
Flow, Max. at 12" H ₂ O (3.0 kPa) Restriction	220 CFM (6.2 m ³ /min)
Secondary Element	Yes
Housing Material	Glass-filled Polyamide
Pre-Cleaner	Integrated
Inlet	Straight, via Pre-Cleaner 3.97" (101.0 mm)
Outlet	Straight 4.08" (103.7 mm)
Filter Efficiency	≥ 99.90% per ISO 5011

Specifications Subject to change without notice.

Dust Holding Capacity per Flow Rate

Specification	Non Aspirated	
	CFM	m ³ /min
Maximum Flow for 10 g/CFM (357.1 g/m ³ /min)	180	5.0
Maximum Flow for 25 g/CFM (892.9 g/m ³ /min)	102	2.8

Dimensions

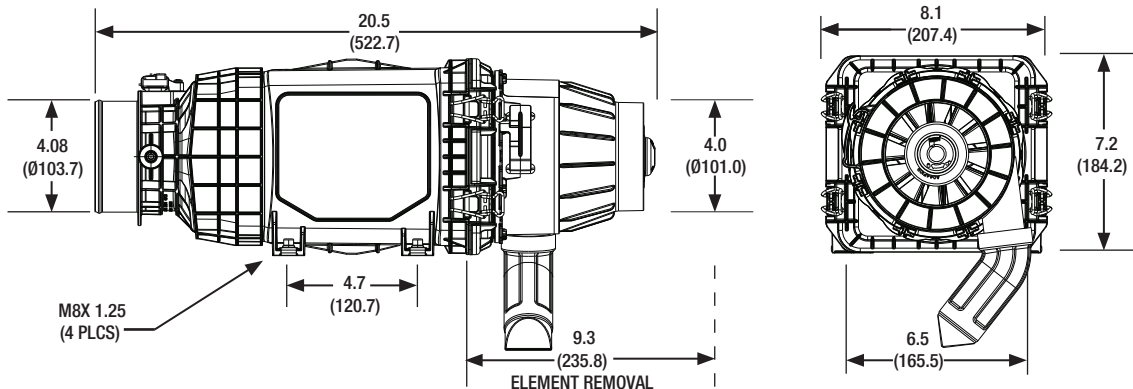

All dimensions are in inches (millimeters)

Ordering Information

Air Cleaners	
Part Number	Description
AK55720	Direct Flow -Front Inlet -Integrated Pre-Cleaner -With TBAP Sensor

Service Parts	
Part Number	Description
AF55030	Primary Element
AF55321	Secondary Element
SP1080	Front Service Cover
AP15910	Pre-Cleaner
SP1048	Dust Ejector Valve (DEV)

Optional Accessories	
Part Number	Description
3316658S	4" Band Clamp
3316660S	5" Band Clamp
3316608S	4" Hump Hose
3316610S	5" Hump Hose
3316568S	4" 90° Elbow
3316570S	5" 90° Elbow
3316618S	5" to 4" Hump Hose Reducer
3946329S	Restriction Indicator

Additional sizes/shapes may be available.
Refer to the Cummins Filtration catalog or website.

Performance

System Restriction vs Flow Rate

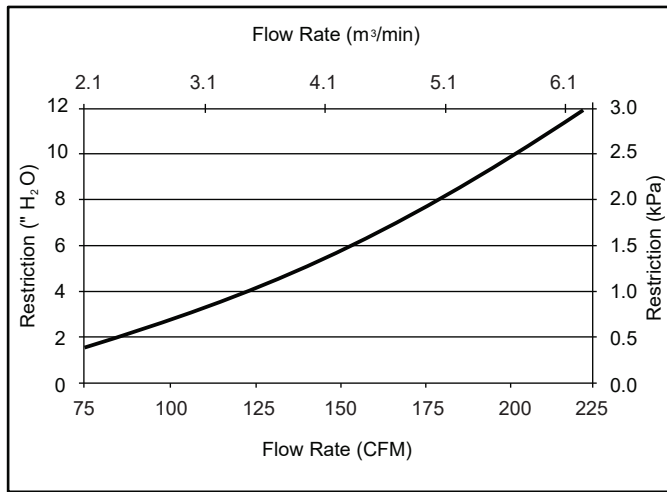

System Capacity vs Flow Rate

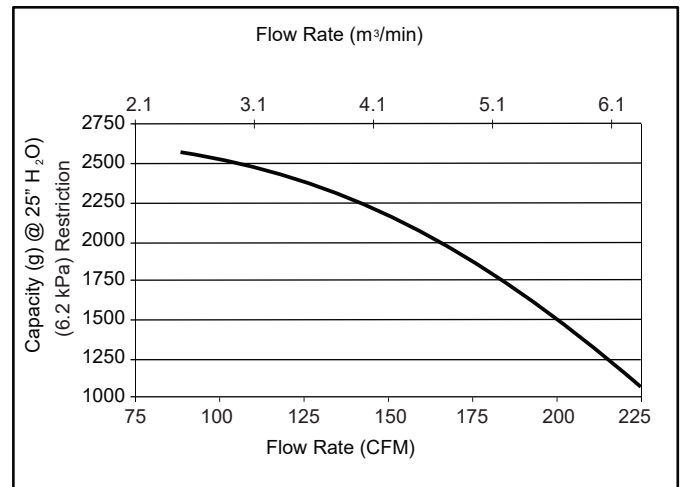

Restriction		Flow Rate		Typical Capacity at 25" H ₂ O (6.2 kPa) of Terminal Restriction
in H ₂ O	kPa	CFM	m³/min	Non Aspirated (g)
4	1.0	123	3.5	2325
6	1.5	160	4.5	2050
8	2.0	178	5.1	1825
10	2.5	200	5.7	1600
12	3.0	220	6.2	1450

ISO Coarse Dust
2.0 g/m³ Feed Rate
25" H₂O (6.2 kPa)
Terminal Restriction
per ISO 5011

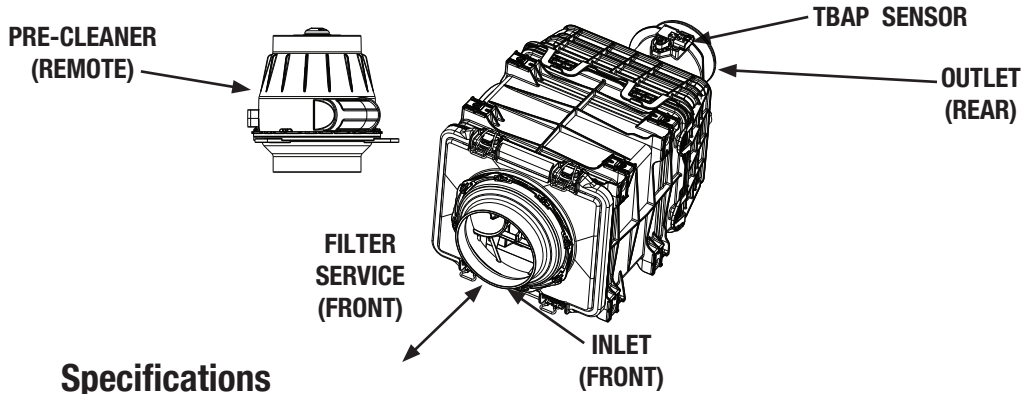

Specifications

Specification	AK55692
Length, Overall	20.5" (521.2 mm)
Width, Overall	10.9" (277.4 mm)
Height, Overall	9.5" (241.3 mm)
Flow, Min. at 2" H ₂ O (0.5 kPa) Restriction	145 CFM (4.1 m ³ /min)
Flow, Max. at 12" H ₂ O (3.0 kPa) Restriction	360 CFM (10.1 m ³ /min)
Secondary Element	Yes
Housing Material	Glass-filled Polyamide
Pre-Cleaner	Remote
Inlet	Straight, 5.0" (Ø127.0 mm)
Outlet	Straight, 4.0" (Ø101.6 mm)
Filter Efficiency	≥ 99.90% per ISO 5011

Specifications Subject to change without notice.

Dust Holding Capacity per Flow Rate

Specification	Non Aspirated	
	CFM	m ³ /min
Maximum Flow for 10 g/CFM (357.1 g/m ³ /min)	360.0*	10.0*
Maximum Flow for 25 g/CFM (892.9 g/m ³ /min)	188.0	5.3

*Indicates maximum recommended flow rate.

Dimensions

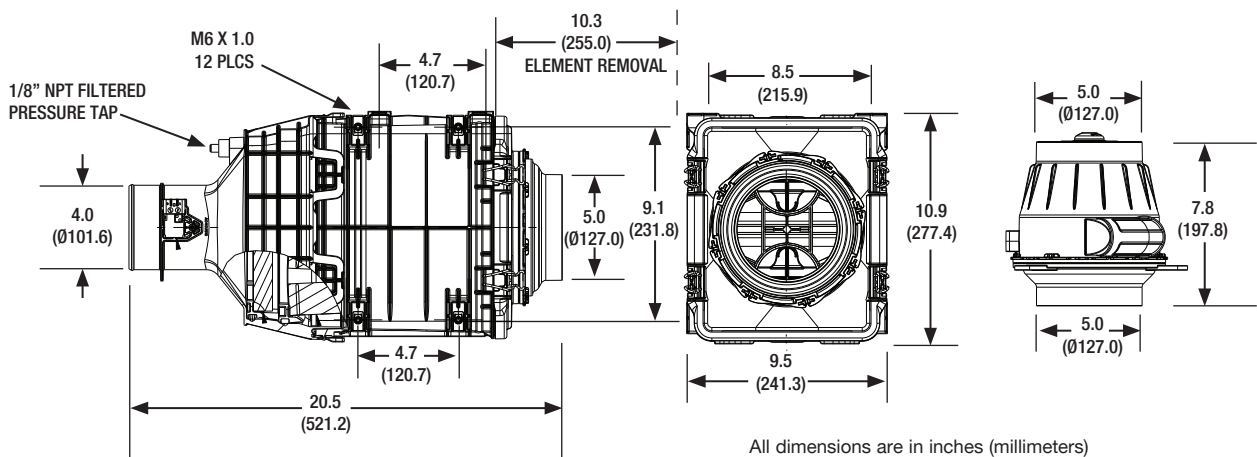

All dimensions are in inches (millimeters)

Ordering Information

Air Cleaners	
Part Number	Description
AK55692	Direct Flow -Remote Pre-Cleaner -Front Inlet -With TBAP Sensor

Service Parts	
Part Number	Description
AF55020	Primary Element
AF55320	Secondary Element
AP15914	Pre-Cleaner
AP15912	Pre-Cleaner Remote Adapter
SP1048	Dust Ejection Valve (DEV)
SP1060	M6 Mounting Clips
SP1042	Front Service Cover

Optional Accessories	
Part Number	Description
3316658S	4" Band Clamp
3316660S	5" Band Clamp
3316608S	4" Hump Hose
3316610S	5" Hump Hose
3316568S	4" 90° Elbow
3316570S	5" 90° Elbow
3316618S	5" to 4" Hump Hose Reducer
3946329S	Restriction Indicator

Additional sizes/shapes may be available. Refer to the Cummins Filtration catalog or website.

Performance

System Restriction vs Flow Rate

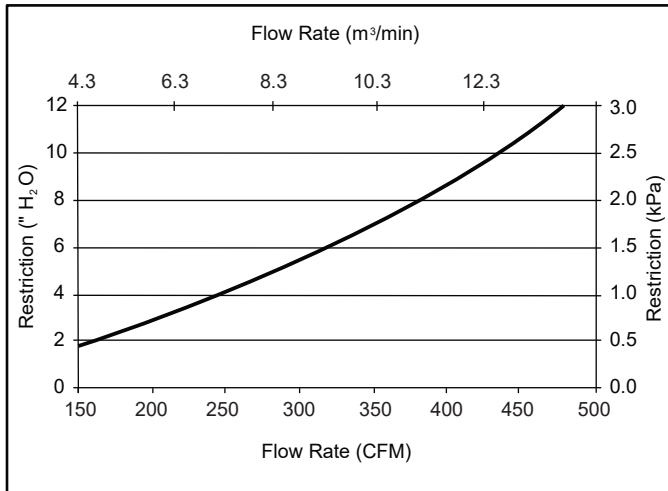

System Capacity vs Flow Rate

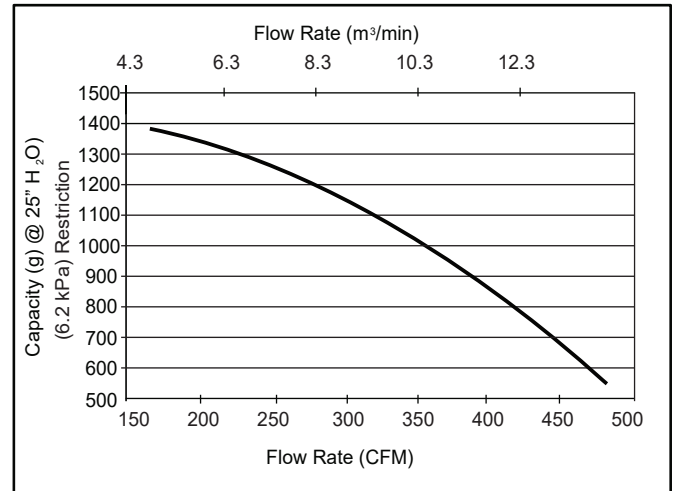

Restriction		Flow Rate		Typical Capacity at 25" H ₂ O (6.2 kPa) of Terminal Restriction
in H ₂ O	kPa	CFM	m³/min	Non Aspirated (g)
4	1.0	210	5.9	4575
6	1.5	260	7.4	4350
8	2.0	300	8.5	4090
10	2.5	338	9.6	3800
12	3.0	360	10.2	3530

ISO Coarse Dust
2.0 g/m³ Feed Rate
25" H₂O (6.2 kPa)
Terminal Restriction
per ISO 5011

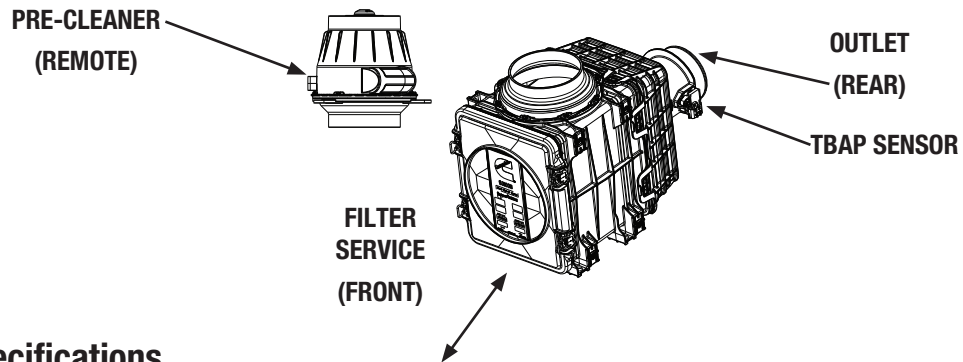

Specifications

Specification	AK55693
Length, Overall	18.4" (469.2 mm)
Width, Overall	9.5" (241.3 mm)
Height, Overall	12.7" (322.8 mm)
Flow, Min. at 2" H ₂ O (0.5 kPa) Restriction	145 CFM (4.1 m ³ /min)
Flow, Max. at 12" H ₂ O (3.0 kPa) Restriction	367 CFM (10.4 m ³ /min)
Secondary Element	Yes
Housing Material	Glass-filled Polyamide
Pre-Cleaner	No
Inlet	90° to Outlet, 5.0" (Ø127.0 mm)
Outlet	Straight 4.0" (Ø101.6 mm)
Filter Efficiency	≥ 99.90% per ISO 5011

Specifications Subject to change without notice.

Dust Holding Capacity per Flow Rate

Specification	Non Aspirated	
	CFM	m ³ /min
Maximum Flow for 10 g/CFM (357.1 g/m ³ /min)	367*	10.4*
Maximum Flow for 25 g/CFM (892.9 g/m ³ /min)	205	5.7

*Indicates maximum recommended flow rate.

Dimensions

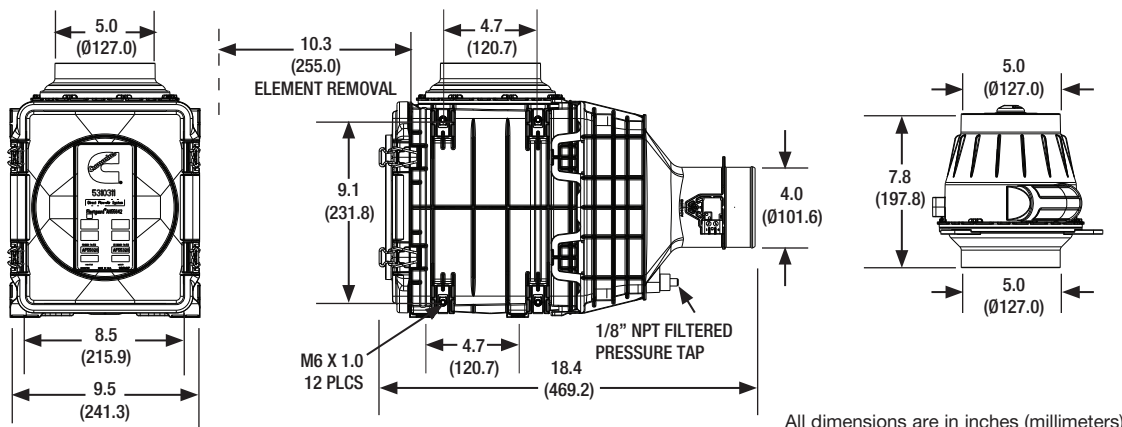

All dimensions are in inches (millimeters)

Ordering Information

Air Cleaners	
Part Number	Description
AK55693	Direct Flow -Remote Pre-Cleaner -Front Inlet -With TBAP Sensor

Service Parts	
Part Number	Description
AF55020	Primary Element
AF55320	Secondary Element
AP15914	Pre-Cleaner
AP15912	Pre-Cleaner Remote Adapter
SP1048	Dust Ejection Valve (DEV)
SP1060	M6 Mounting Clips
SP1041	Front Service Cover

Optional Accessories	
Part Number	Description
3316658S	4" Band Clamp
3316660S	5" Band Clamp
3316608S	4" Hump Hose
3316610S	5" Hump Hose
3316568S	4" 90° Elbow
3316570S	5" 90° Elbow
3316618S	5" to 4" Hump Hose Reducer
3946329S	Restriction Indicator

Additional sizes/shapes may be available. Refer to the Cummins Filtration catalog or website.

Performance

System Restriction vs Flow Rate

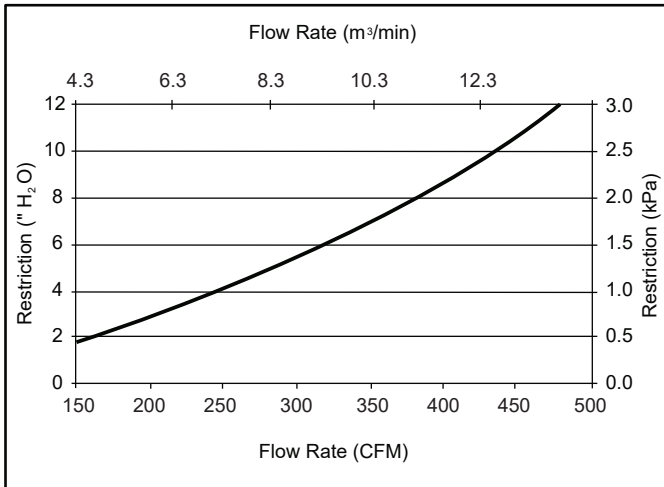

System Capacity vs Flow Rate

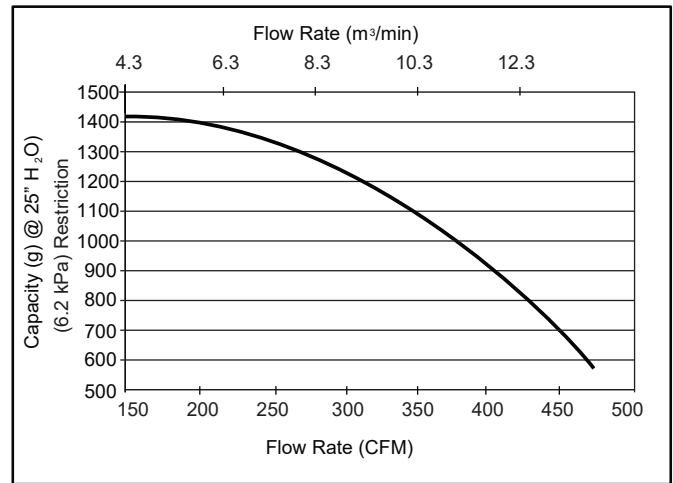

*Data reflects the Pre-Cleaner as Integrated.

Restriction		Flow Rate		Typical Capacity at 25" H ₂ O (6.2 kPa) of Terminal Restriction
in H ₂ O	kPa	CFM	m³/min	
4	1.0	210	5.9	5130
6	1.5	257	7.3	4750
8	2.0	297	8.4	4350
10	2.5	335	9.5	3900
12	3.0	367	10.4	3550

ISO Coarse Dust
2.0 g/m³ Feed Rate
25" H₂O (6.2 kPa)
Terminal Restriction
per ISO 5011

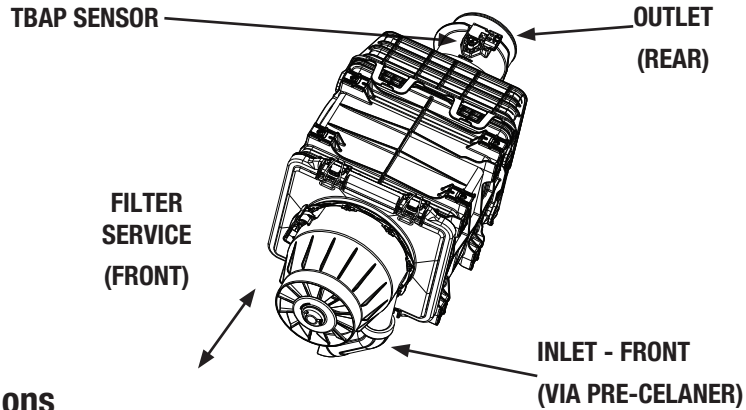

Specifications

Specification	AK55694
Length, Overall	24.7" (629.0 mm)
Width, Overall	10.9" (277.4 mm)
Height, Overall	9.5" (241.3 mm)
Flow, Min. at 2" H ₂ O (0.5 kPa) Restriction	145 CFM (4.1 m ³ /min)
Flow, Max. at 12" H ₂ O (3.0 kPa) Restriction	360 CFM (10.2 m ³ /min)
Secondary Element	Yes
Housing Material	Glass-filled Polyamide
Pre-Cleaner	Integrated
Inlet	Straight - via Pre-cleaner 5.0" (Ø127.0 mm)
Outlet	Straight 4.0" (Ø101.6 mm)
Filter Efficiency	≥ 99.90% per ISO 5011

Specifications Subject to change without notice.

Dust Holding Capacity per Flow Rate

Specification	Non Aspirated	
	CFM	m ³ /min
Maximum Flow for 10 g/CFM (357.1 g/m ³ /min)	360*	10.2*
Maximum Flow for 25 g/CFM (892.9 g/m ³ /min)	188	5.3

*Indicates maximum recommended flow rate.

Dimensions

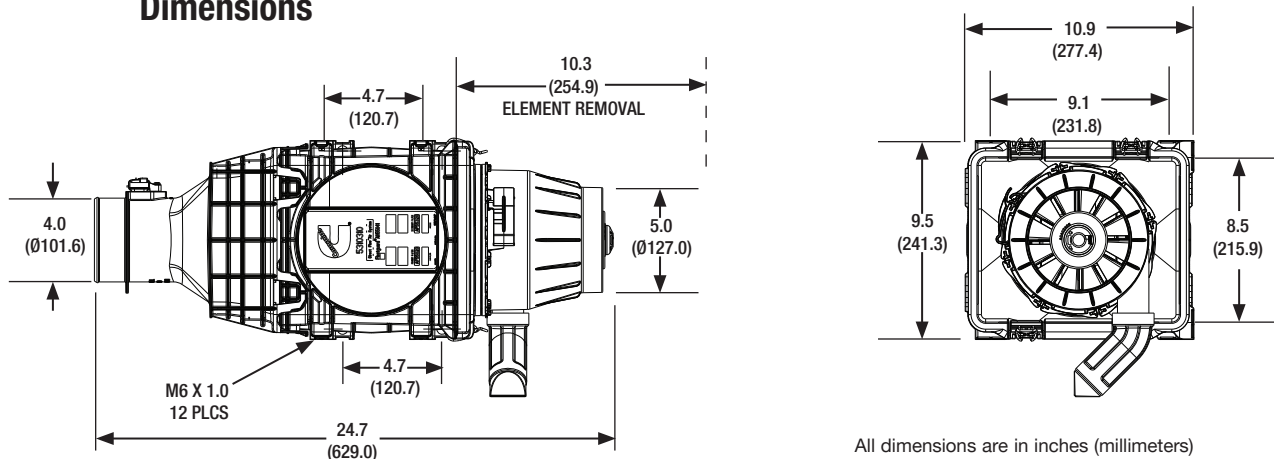

All dimensions are in inches (millimeters)

Ordering Information

Air Cleaners	
Part Number	Description
AK55694	Direct Flow -Front Inlet -With TBAP Sensor -Integrated Pre-Cleaner

Service Parts	
Part Number	Description
AF55020	Primary Element
AF55320	Secondary Element
SP1048	Dust Ejection valve (DEV)
SP1060	M6 Mounting Clips
SP1042	Front Service Cover
AP15914	Pre-Cleaner

Optional Accessories	
Part Number	Description
3316658S	4" Band Clamp
3316660S	5" Band Clamp
3316608S	4" Hump Hose
3316610S	5" Hump Hose
3316568S	4" 90° Elbow
3316570S	5" 90° Elbow
3316618S	5" to 4" Hump Hose Reducer
3946329S	Restriction Indicator

Additional sizes/shapes may be available. Refer to the Cummins Filtration catalog or website.

Performance

System Restriction vs Flow Rate

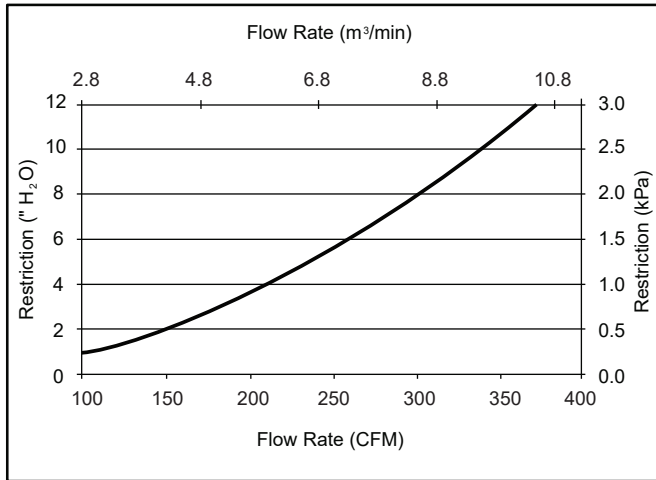

System Capacity vs Flow Rate

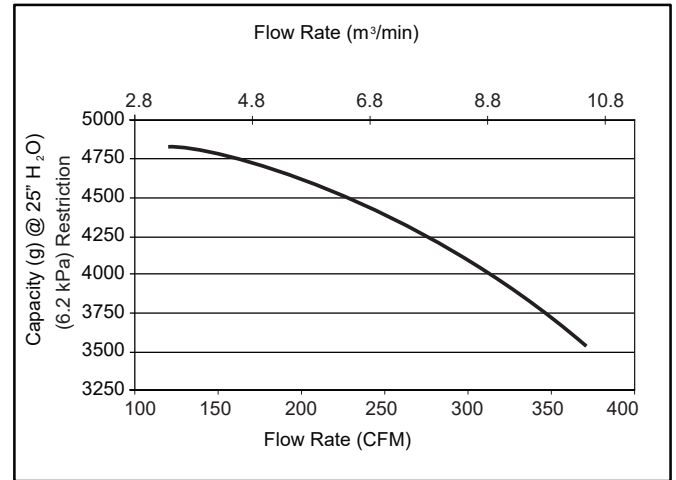

Restriction		Flow Rate		Typical Capacity at 25" H ₂ O (6.2 kPa) of Terminal Restriction
in H ₂ O	kPa	CFM	m³/min	Non Aspirated (g)
4	1.0	210	5.9	4575
6	1.5	260	7.4	4350
8	2.0	300	8.5	4090
10	2.5	338	9.6	3800
12	3.0	360	10.2	3530

ISO Coarse Dust
2.0 g/m³ Feed Rate
25" H₂O (6.2 kPa)
Terminal Restriction
per ISO 5011

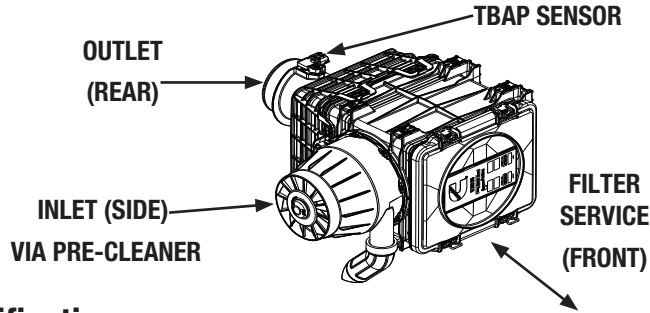

Specifications

Specification	AK55695
Length, Overall	18.4" (469.2 mm)
Width, Overall	16.9" (430.0 mm)
Height, Overall	9.5" (241.3 mm)
Flow, Min. at 2" H ₂ O (0.5 kPa) Restriction	145 CFM (4.1 m ³ /min)
Flow, Max. at 12" H ₂ O (3.0 kPa) Restriction	367 CFM (10.4 m ³ /min)
Secondary Element	Yes
Housing Material	Glass-filled Polyamide
Pre-Cleaner	Integrated
Inlet	90° to Outlet - via Pre-Cleaner 5.0" (Ø127.0 mm)
Outlet	Straight 4.0" (Ø101.6 mm)
Filter Efficiency	≥ 99.90% per ISO 5011

Specifications Subject to change without notice.

Dust Holding Capacity per Flow Rate

Specification	Non Aspirated	
	CFM	m ³ /min
Maximum Flow for 10 g/CFM (357.1 g/m ³ /min)	367*	10.4*
Maximum Flow for 25 g/CFM (892.9 g/m ³ /min)	205	5.7

*Indicates maximum recommended flow rate.

Dimensions

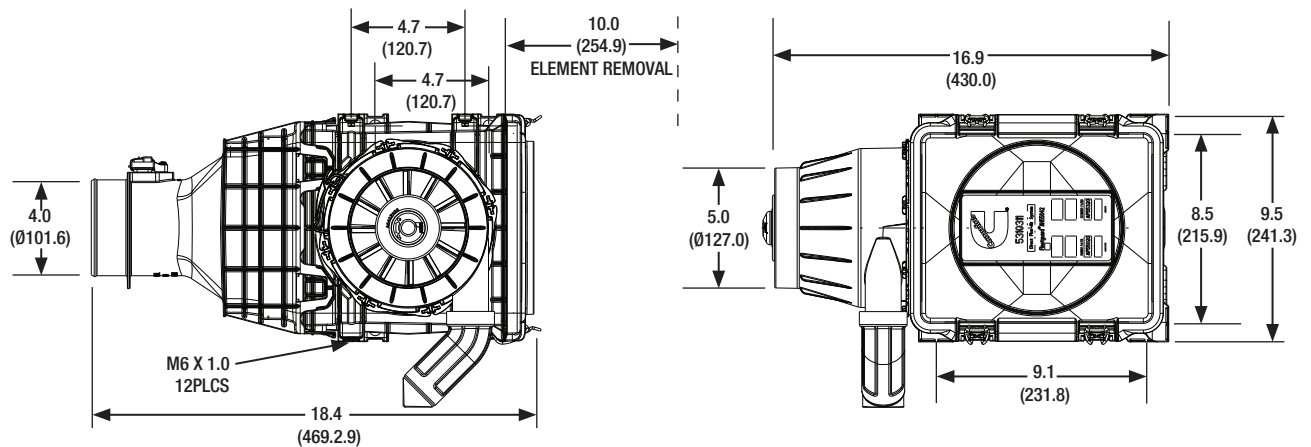

All dimensions are in inches (millimeters)

Ordering Information

Air Cleaners	
Part Number	Description
AK55695	Direct Flow -Integrated Pre-Cleaner -Front Inlet -With TBAP Sensor

Service Parts	
Part Number	Description
AF55020	Primary Element
AF55320	Secondary Element
SP1048	Dust Ejection Valve (DEV)
SP1060	M6 Mounting Clips
SP1041	Front Service Cover
AP15914	Pre-Cleaner

Optional Accessories	
Part Number	Description
3316658S	4" Band Clamp
3316660S	5" Band Clamp
3316608S	4" Hump Hose
3316610S	5" Hump Hose
3316568S	4" 90° Elbow
3316570S	5" 90° Elbow
3316618S	5" to 4" Hump Hose Reducer
3946329S	Restriction Indicator

Additional sizes/shapes may be available.
Refer to the Cummins Filtration catalog or website.

Performance

System Restriction vs Flow Rate

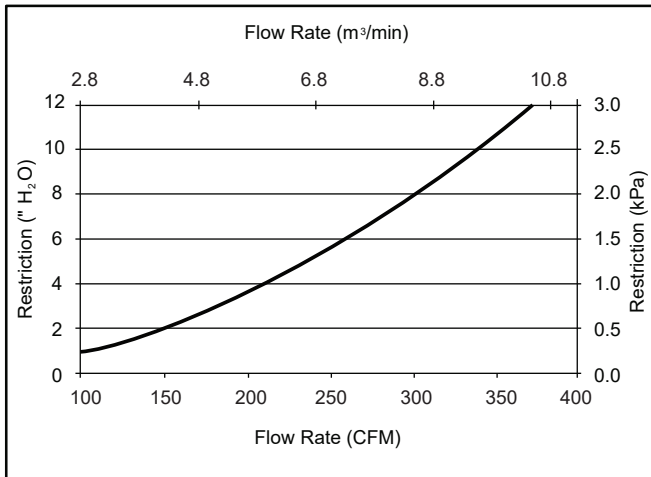

System Capacity vs Flow Rate

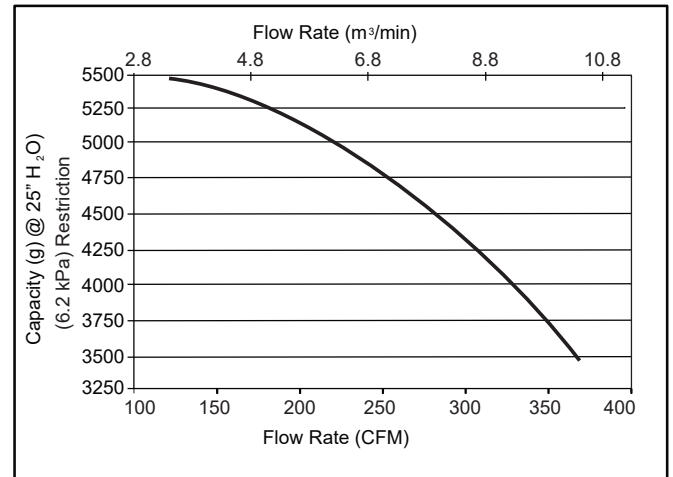

Restriction		Flow Rate		Typical Capacity at 25" H ₂ O (6.2 kPa) of Terminal Restriction Non Aspirated (g)
in H ₂ O	kPa	CFM	m³/min	
4	1.0	210	5.9	5130
6	1.5	257	7.3	4750
8	2.0	297	8.4	4350
10	2.5	335	9.5	3900
12	3.0	367	10.4	3550

ISO Coarse Dust
2.0 g/m³ Feed Rate
25" H₂O (6.2 kPa)
Terminal Restriction
per ISO 5011

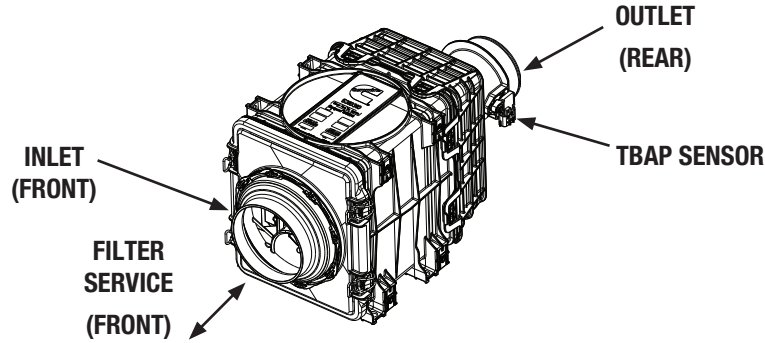

Specifications

Specification	AH55641
Length, Overall	20.5" (521.0 mm)
Width, Overall	9.5" (241.3 mm)
Height, Overall	10.9" (277.4 mm)
Flow, Min. at 2" H ₂ O (0.5 kPa) Restriction	175 CFM (4.9 m ³ /min)
Flow, Max. at 12" H ₂ O (3.0 kPa) Restriction	475 CFM (13.5 m ³ /min)
Secondary Element	Yes
Housing Material	Glass-filled Polyamide
Pre-Cleaner	No
Inlet	Straight, 5.0" (Ø127.0 mm)
Outlet	Straight, 4.0" (Ø101.6 mm)
Filter Efficiency	≥ 99.90% per ISO 5011

Specifications Subject to change without notice.

Dust Holding Capacity per Flow Rate

Specification	Non Aspirated	
	CFM	m ³ /min
Maximum Flow for 10 g/CFM (357.1 g/m ³ /min)	175	4.9
Maximum Flow for 25 g/CFM (892.9 g/m ³ /min)	N/A	N/A

Dimensions

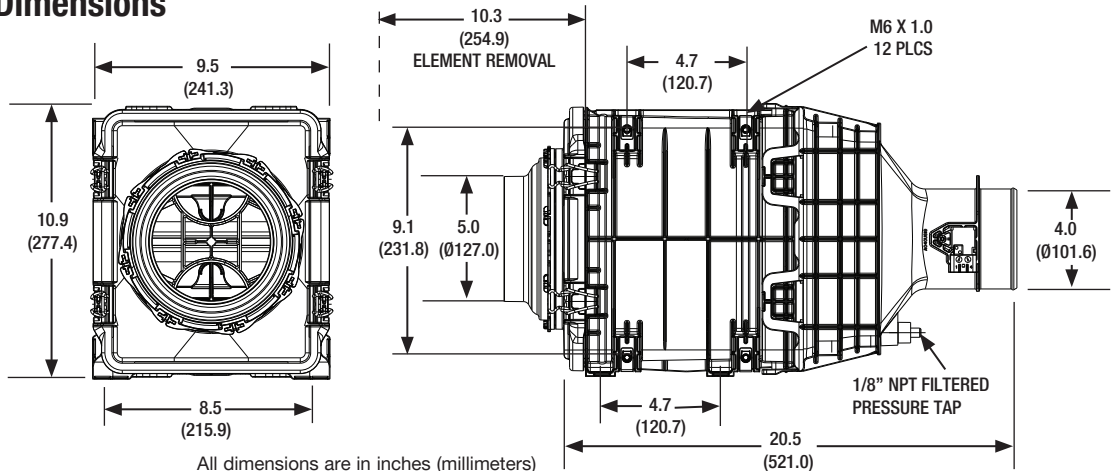

All dimensions are in inches (millimeters)

Ordering Information

Air Cleaners	
Part Number	Description
AH55641	Direct Flow -Front Inlet -With TBAP Sensor

Service Parts	
Part Number	Description
AF55020	Primary Element
AF55320	Secondary Element
SP1042	Front Service Cover
SP1060	M6 Mounting Clips

Optional Accessories	
Part Number	Description
3316658S	4" Band Clamp
3316660S	5" Band Clamp
3316608S	4" Hump Hose
3316610S	5" Hump Hose
3316568S	4" 90° Elbow
3316570S	5" 90° Elbow
3316618S	5" to 4" Hump Hose Reducer
3946329S	Restriction Indicator

Additional sizes/shapes may be available.
Refer to the Cummins Filtration catalog or website.

Performance

System Restriction vs Flow Rate

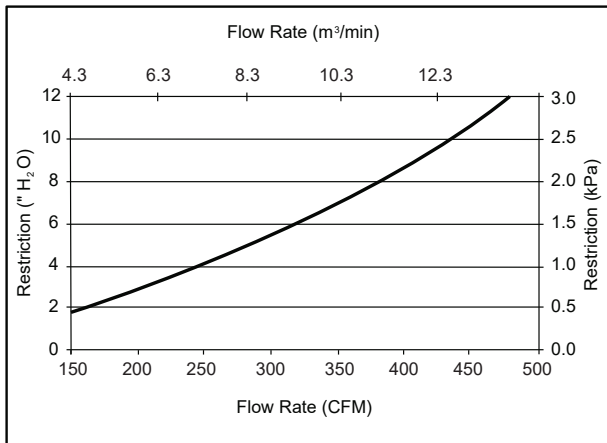

System Capacity vs Flow Rate

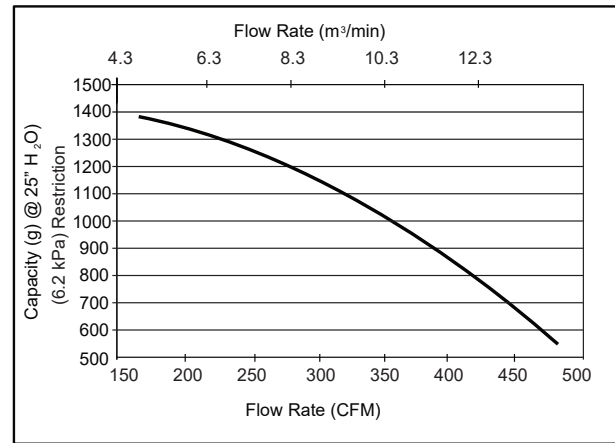

Restriction		Flow Rate		Typical Capacity at 25" H ₂ O (6.2 kPa) of Terminal Restriction
in H ₂ O	kPa	CFM	m³/min	Non Aspirated (g)
4	1.0	260	7.4	1325
6	1.5	330	9.3	1150
8	2.0	382	10.8	988
10	2.5	433	12.3	813
12	3.0	475	13.2	638

ISO Fine Dust
1.0 g/m³ Feed Rate
25" H₂O (6.2 kPa)
Terminal Restriction
per ISO 5011

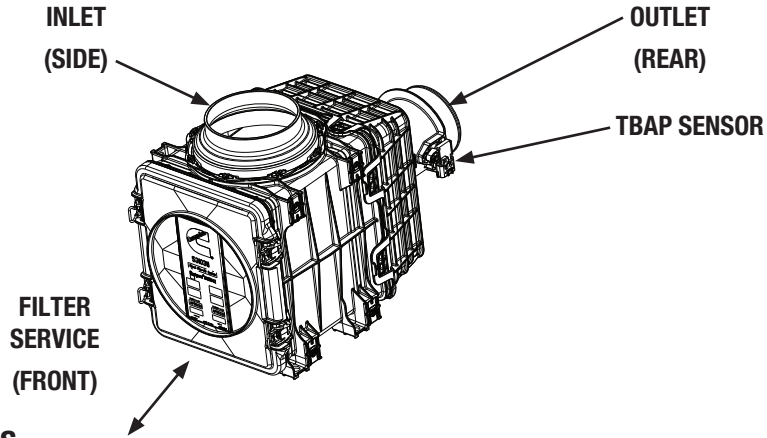

Specifications

Specification	AH55642
Length, Overall	18.5" (469.2 mm)
Width, Overall	9.5" (241.3 mm)
Height, Overall	12.7" (322.8 mm)
Flow, Min. at 2" H ₂ O (0.5 kPa) Restriction	175 CFM (4.9 m ³ /min)
Flow, Max. at 12" H ₂ O (3.0 kPa) Restriction	470 CFM (13.3 m ³ /min)
Secondary Element	Yes
Housing Material	Glass-filled Polyamide
Pre-Cleaner	No
Inlet	90° to Outlet, 5.0" (Ø127.0 mm)
Outlet	Straight 4.0" (101.6 mm)
Filter Efficiency	≥ 99.90% per ISO 5011

Specifications Subject to change without notice.

Dust Holding Capacity per Flow Rate

Specification	Non Aspirated	
	CFM	m ³ /min
Maximum Flow for 10 g/CFM (357.1 g/m ³ /min)	175	4.9
Maximum Flow for 25 g/CFM (892.9 g/m ³ /min)	N/A	N/A

* Requires Pre-Cleaner (Optional)

Dimensions

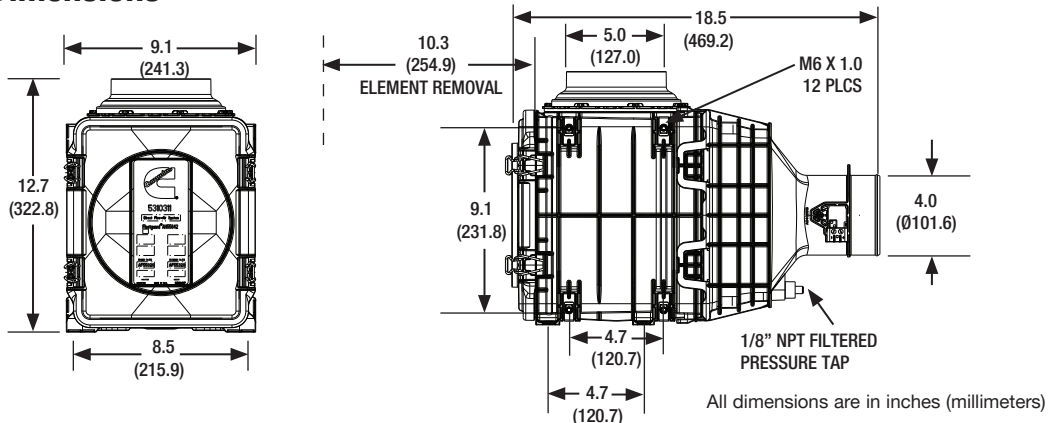

Ordering Information

Air Cleaners		Service Parts		Optional Accessories	
Part Number	Description	Part Number	Description	Part Number	Description
AH55642	Direct Flow -Side Inlet -With TBAP Sensor	AF55020	Primary Element	3316658S	4" Band Clamp
		AF55320	Secondary Element	3316660S	5" Band Clamp
		SP1080	Front Service Cover	3316608S	4" Hump Hose
		SP1060	M6 Mounting Clips	3316610S	5" Hump Hose
				3316568S	4" 90° Elbow
				3316570S	5" 90° Elbow
				3316618S	5" to 4" Hump Hose Reducer
				3946329S	Restriction Indicator

Additional sizes/shapes may be available.
Refer to the Cummins Filtration catalog or website.

Performance

System Restriction vs Flow Rate

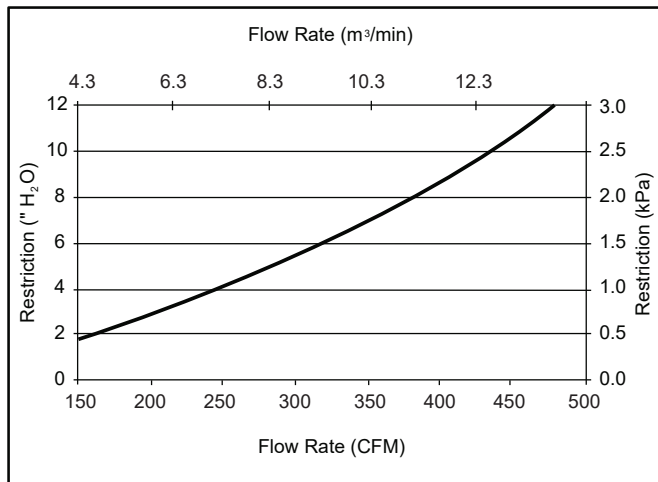

System Capacity vs Flow Rate

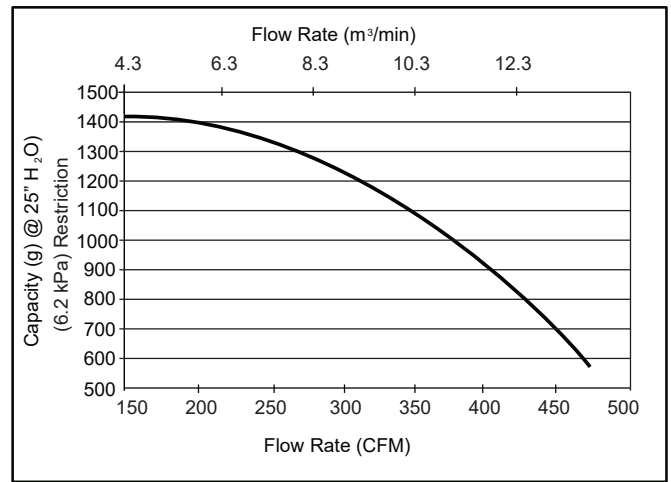

Restriction		Flow Rate		Typical Capacity at 25" H ₂ O (6.2 kPa) of Terminal Restriction
in H ₂ O	kPa	CFM	m³/min	Non Aspirated (g)
4	1.0	260	7.4	1325
6	1.5	325	9.2	1175
8	2.0	380	10.8	988
10	2.5	430	12.2	775
12	3.0	470	13.3	575

ISO Fine Dust
1.0 g/m³ Feed Rate
25" H₂O (6.2 kPa)
Terminal Restriction
per ISO 5011

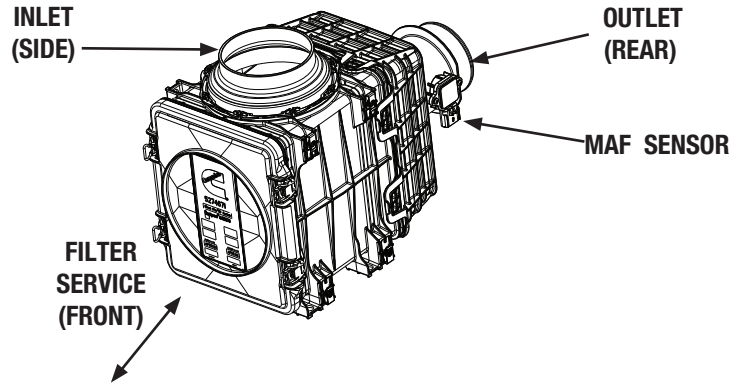

Specifications

Specification	AH55579
Length, Overall	18.5" (469.2 mm)
Width, Overall	9.5" (241.3 mm)
Height, Overall	12.7" (322.8 mm)
Flow, Min. at 2" H ₂ O (0.5 kPa) Restriction	133 CFM (3.8 m ³ /min)
Flow, Max. at 12" H ₂ O (3.0 kPa) Restriction	341 CFM (9.6 m ³ /min)
Secondary Element	Yes
Housing Material	Glass-filled Polyamide
Pre-Cleaner	No
Inlet	90° to Outlet, 5.0" (Ø127.0 mm)
Outlet	Straight, 4.0" (Ø101.6 mm)
Filter Efficiency	≥ 99.90% per ISO 5011

Specifications Subject to change without notice.

Dust Holding Capacity per Flow Rate

Specification	Non Aspirated	
	CFM	m ³ /min
Maximum Flow for 10 g/CFM (357.1 g/m ³ /min)	137*	3.9*
Minimum Flow for 25 g/CFM (892.9 g/m ³ /min)	N/A	N/A

*Indicates maximum recommended flow rate.

Dimensions

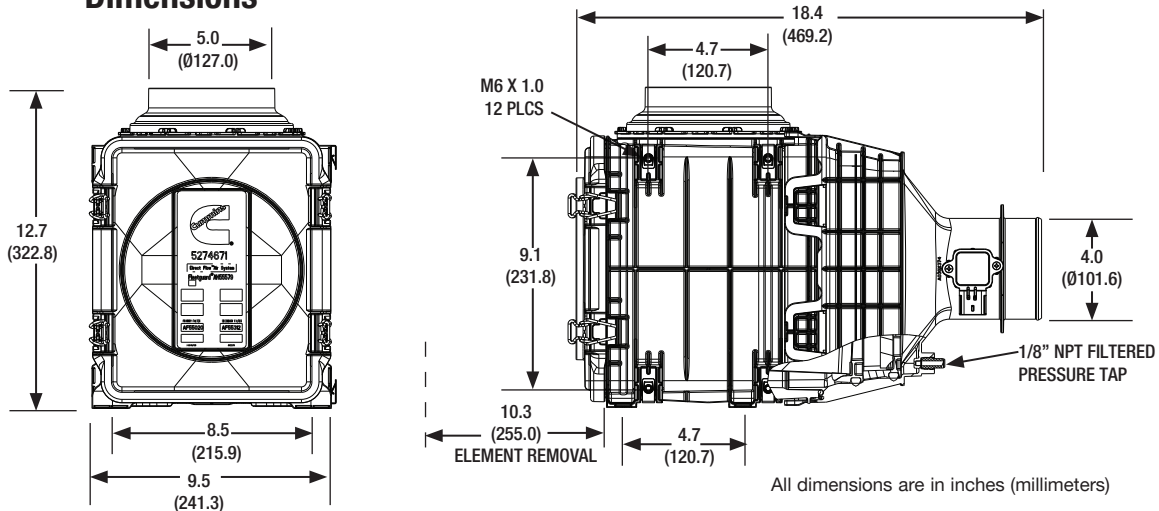

All dimensions are in inches (millimeters)

Ordering Information

Air Cleaners	
Part Number	Description
AH55579	Direct Flow -Front Inlet -With MAF Sensor

Service Parts	
Part Number	Description
AF55020	Primary Element
AF55312	Secondary Element
SP1048	Dust Ejection Valve (DEV)
SP1060	M6 Mounting Clips
SP1041	Front Service Cover

Optional Accessories	
Part Number	Description
3316658S	4" Band Clamp
3316660S	5" Band Clamp
3316608S	4" Hump Hose
3316610S	5" Hump Hose
3316568S	4" 90° Elbow
3316570S	5" 90° Elbow
3316618S	5" to 4" Hump Hose Reducer
3946329S	Restriction Indicator

Additional sizes/shapes may be available. Refer to the Cummins Filtration catalog or website.

Performance

System Restriction vs Flow Rate

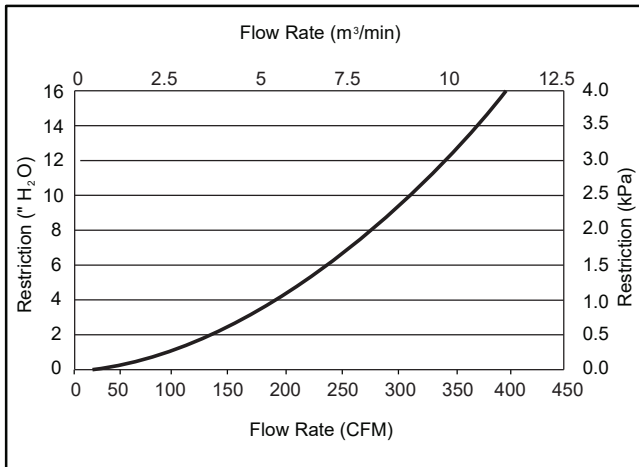

System Capacity vs Flow Rate

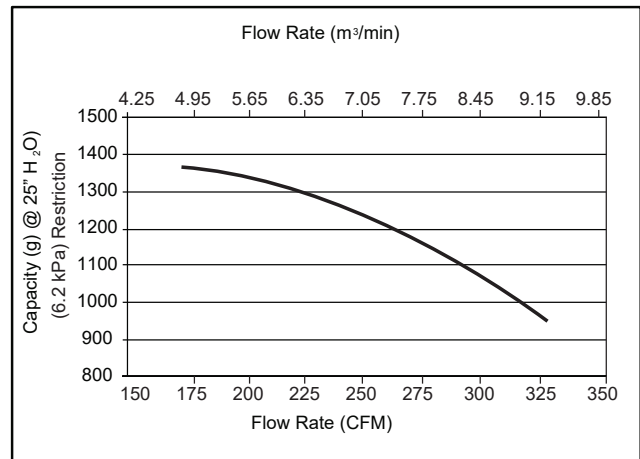

Restriction		Flow Rate		Typical Capacity at 25" H ₂ O (6.2 kPa) of Terminal Restriction
in H ₂ O	kPa	CFM	m ³ /min	Non Aspirated (g)
4	1.0	185	5.2	1352.6
6	1.5	231	6.5	1274.2
8	2.0	272	7.7	1153.6
10	2.5	309	8.7	1006.9
12	3.0	341	9.6	848.4

ISO Fine Dust
1.0 g/m³ Feed Rate
25" H₂O (6.2 kPa)
Terminal Restriction
per ISO 5011

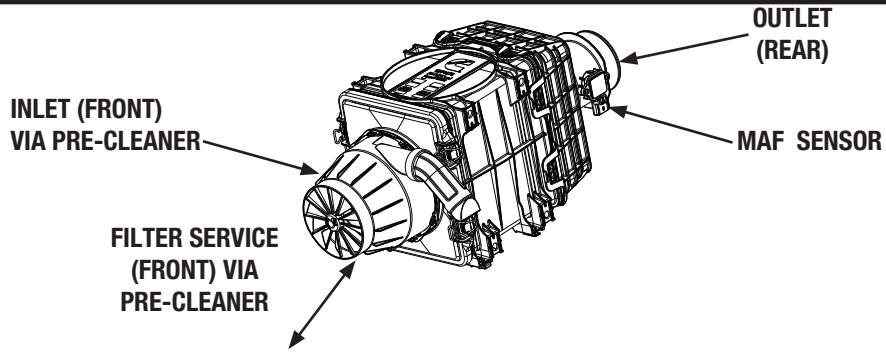

Specifications

Specification	AH55582
Length, Overall	24.4" (620.7 mm)
Width, Overall	9.5" (241.3 mm)
Height, Overall	10.9" (277.4 mm)
Flow, Min. at 2" H ₂ O (0.5 kPa) Restriction	120 CFM (3.4 m ³ /min)
Flow, Max. at 12" H ₂ O (3.0 kPa) Restriction	308 CFM (8.7 m ³ /min)
Secondary Element	Yes
Housing Material	Glass-filled Polyamide
Pre-Cleaner	Integrated
Inlet	Straight - via Pre-Cleaner, 5.0" (Ø127.0 mm)
Outlet	Straight, 4.0" (Ø101.6 mm)
Filter Efficiency	≥ 99.90% per ISO 5011

Specifications Subject to change without notice.

Dust Holding Capacity per Flow Rate

Specification	Non Aspirated	
	CFM	m ³ /min
Maximum Flow for 10 g/CFM (357.1 g/m ³ /min)	298*	8.4*
Minimum Flow for 25 g/CFM (892.9 g/m ³ /min)	152	4.3

*Indicates maximum recommended flow rate.

Dimensions

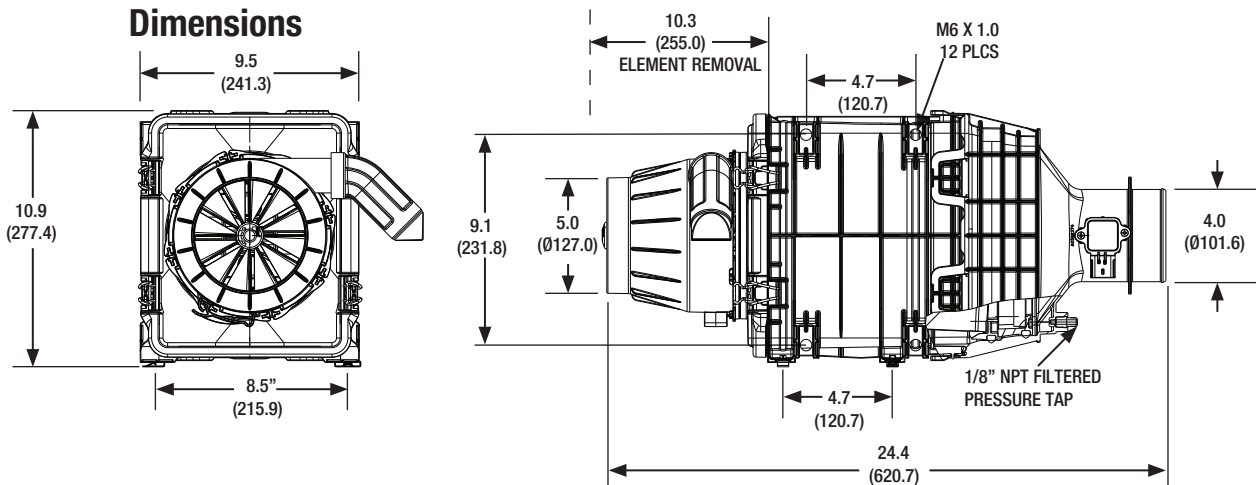

All dimensions are in inches (millimeters)

Ordering Information

Air Cleaners	
Part Number	Description
AH55582	Direct Flow -Integrated Pre-Cleaner -Front Inlet -With MAF Sensor

Service Parts	
Part Number	Description
AF55020	Primary Element
AF55312	Secondary Element
AP15909	Pre-Cleaner
SP1054	Mass Airflow Sensor
SP1048	Dust Ejection Valve (DEV)
SP1060	M6 Mounting Clips
SP1042	Front Service Cover

Optional Accessories	
Part Number	Description
3316658S	4" Band Clamp
3316660S	5" Band Clamp
3316608S	4" Hump Hose
3316610S	5" Hump Hose
3316568S	4" 90° Elbow
3316570S	5" 90° Elbow
3316618S	5" to 4" Hump Hose Reducer
3946329S	Restriction Indicator

Additional sizes/shapes may be available. Refer to the Cummins Filtration catalog or website.

Performance

System Restriction vs Flow Rate

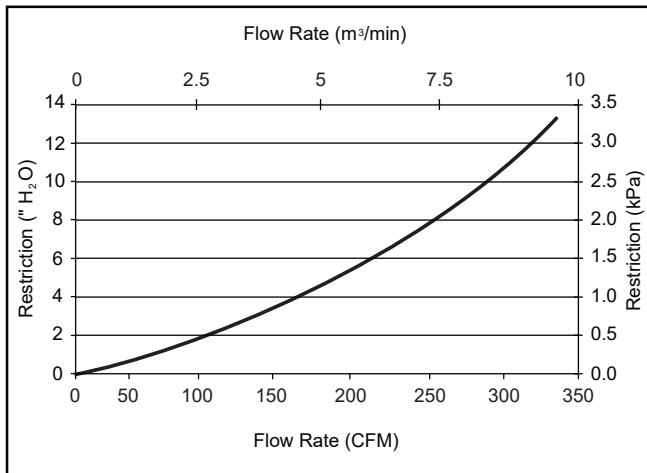

System Capacity vs Flow Rate

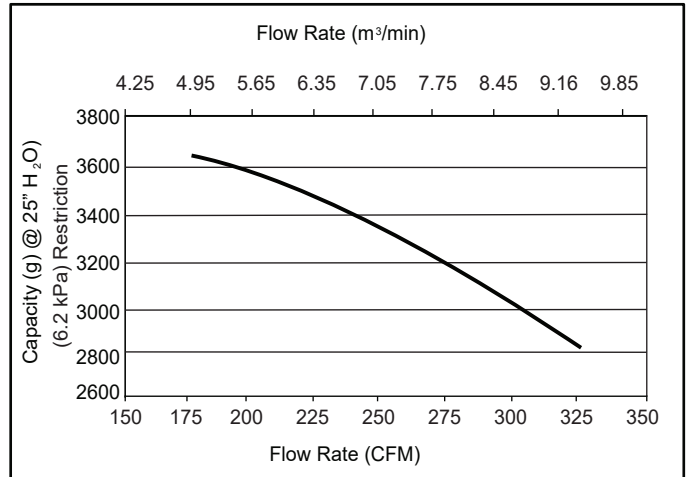

Restriction		Flow Rate		Typical Capacity at 25" H ₂ O (6.2 kPa) of Terminal Restriction	Typical Capacity at 30" H ₂ O (6.2 kPa) of Terminal Restriction
in H ₂ O	kPa	CFM	m³/min	Non Aspirated (g)	Non Aspirated (g)
4	1.0	170	4.8	3650	3730
6	1.5	213	6.0	3480	3590
8	2.0	248	7.0	3310	3500
10	2.5	280	7.9	3120	3440
12	3.0	308	8.7	2920	3390

ISO Coarse Dust
2.0 g/m³ Feed Rate
25" H₂O (6.2 kPa)
Terminal Restriction
per ISO 5011

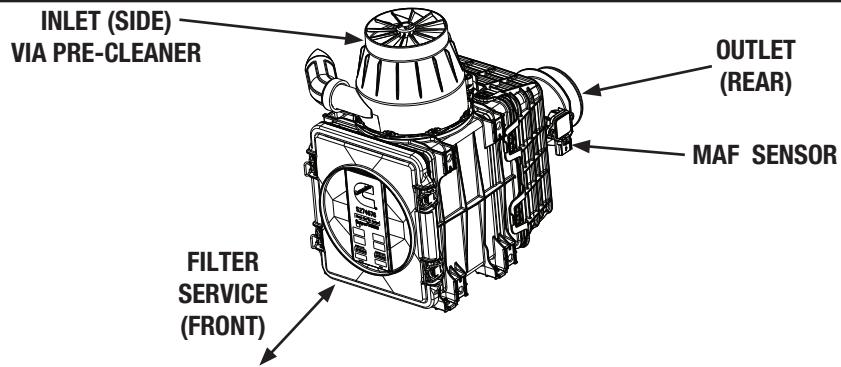

Specifications

Specification	AH55583
Length, Overall	18.4" (469.2 mm)
Width, Overall	9.5" (241.3 mm)
Height, Overall	16.6" (423.4 mm)
Flow, Min. at 2" H ₂ O (0.5 kPa) Restriction	115 CFM (3.3 m ³ /min)
Flow, Max. at 12" H ₂ O (3.0 kPa) Restriction	308 CFM (8.7 m ³ /min)
Secondary Element	Yes
Housing Material	Glass-filled Polyamide
Pre-Cleaner	Integrated
Inlet	90° to Outlet - via Pre-Cleaner, 5.0" (Ø127.00.0 mm)
Outlet	Straight, 4.0" (Ø101.6 mm)
Filter Efficiency	≥ 99.90% per ISO 5011

Specifications Subject to change without notice.

Dust Holding Capacity per Flow Rate

Specification	Non Aspirated	
	CFM	m ³ /min
Maximum Flow for 10 g/CFM (357.1 g/m ³ /min)	296*	8.4*
Maximum Flow for 25 g/CFM (892.9 g/m ³ /min)	152	4.3

*Indicates maximum recommended flow rate.

Dimensions

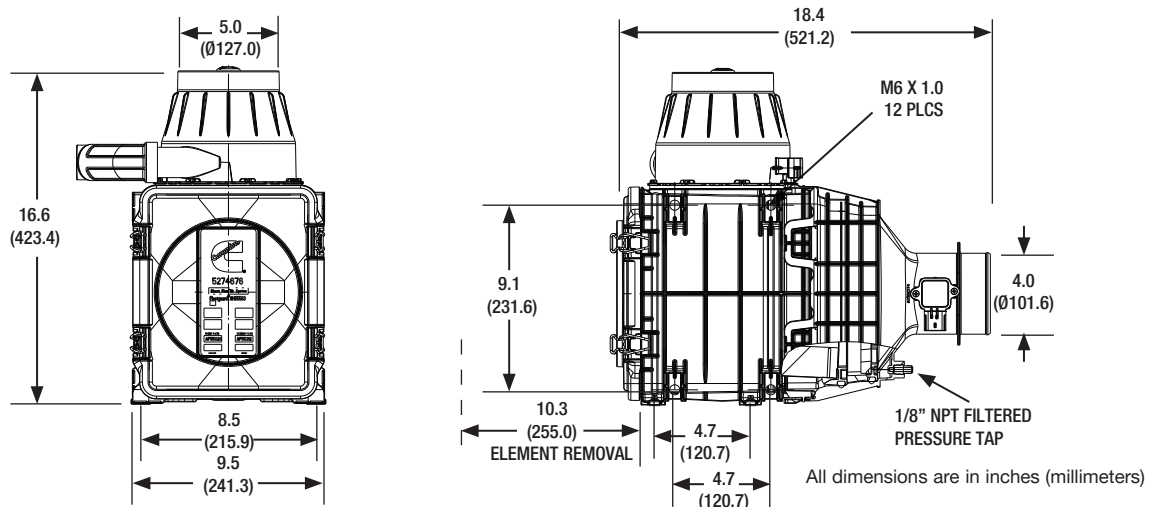

Ordering Information

Air Cleaners	
Part Number	Description
AH55583	Direct Flow -Integrated Pre-Cleaner -Side Inlet -With MAF Sensor

Service Parts	
Part Number	Description
AF55020	Primary Element
AF55312	Secondary Element
SP1054	Mass Airflow Sensor
SP1041	Front Service Cover
SP1048	Dust Ejection Valve (DEV)
SP1060	M6 Mounting Clips
AP15909	Pre-Cleaner

Optional Accessories	
Part Number	Description
3316658S	4" Band Clamp
3316660S	5" Band Clamp
3316608S	4" Hump Hose
3316610S	5" Hump Hose
3316568S	4" 90° Elbow
3316570S	5" 90° Elbow
3316618S	5" to 4" Hump Hose Reducer
3946329S	Restriction Indicator

Additional sizes/shapes may be available.
Refer to the Cummins Filtration catalog or website.

Performance

System Restriction vs Flow Rate

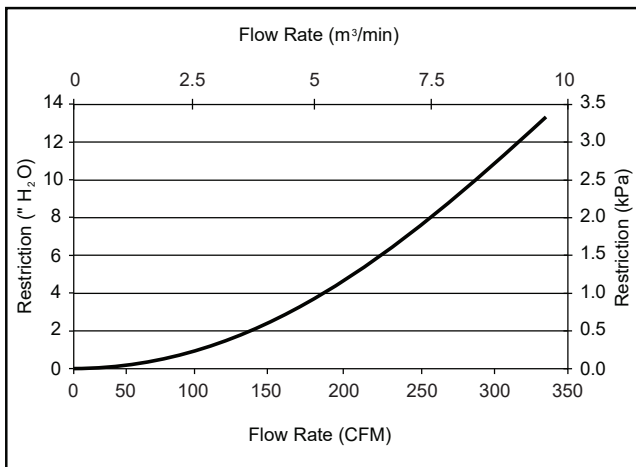

System Capacity vs Flow Rate

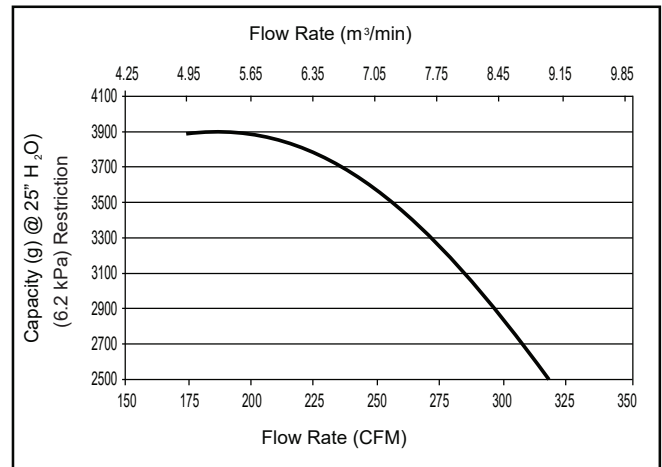

Restriction		Flow Rate		Typical Capacity at 25" H ₂ O (6.2 kPa) of Terminal Restriction	Typical Capacity at 30" H ₂ O (6.2 kPa) of Terminal Restriction
in H ₂ O	kPa	CFM	m ³ /min	Non Aspirated (g)	Non Aspirated (g)
4	1.0	165	4.6	3850	3970
6	1.5	210	6.0	3840	3960
8	2.0	248	7.0	3580	3790
10	2.5	280	7.9	3200	3520
12	3.0	308	8.7	2730	3200

ISO Coarse Dust
2.0 g/m³ Feed Rate
25" H₂O (6.2 kPa)
Terminal Restriction
per ISO 5011

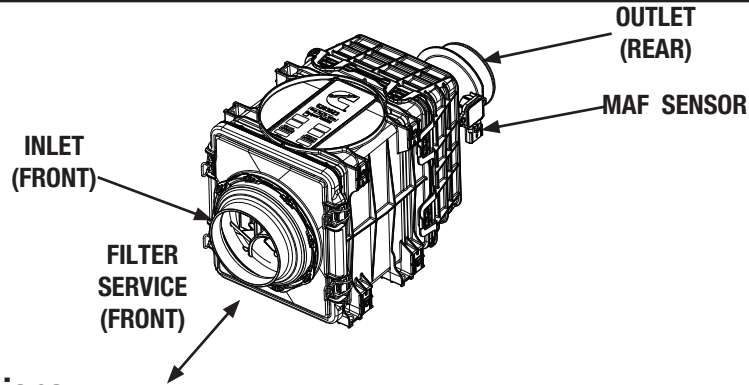

Specifications

Specification	AH55592
Length, Overall	20.5" (521.0 mm)
Width, Overall	9.5" (241.3 mm)
Height, Overall	10.9" (277.4 mm)
Flow, Min. at 2" H ₂ O (0.5 kPa) Restriction	133 CFM (3.8 m ³ /min)
Flow, Max. at 12" H ₂ O (3.0 kPa) Restriction	346 CFM (9.8 m ³ /min)
Secondary Element	Yes
Housing Material	Glass-filled Polyamide
Pre-Cleaner	No
Inlet	Straight, 5.0" (Ø127.0 mm)
Outlet	Straight, 4.0" (Ø101.6 mm)
Filter Efficiency	≥ 99.90% per ISO 5011

Specifications Subject to change without notice.

Dust Holding Capacity per Flow Rate

Specification	Non Aspirated	
	CFM	m ³ /min
Maximum Flow for 10 g/CFM (357.1 g/m ³ /min)	149	5.9
Maximum Flow for 25 g/CFM (892.9 g/m ³ /min)	N/A	N/A

Dimensions

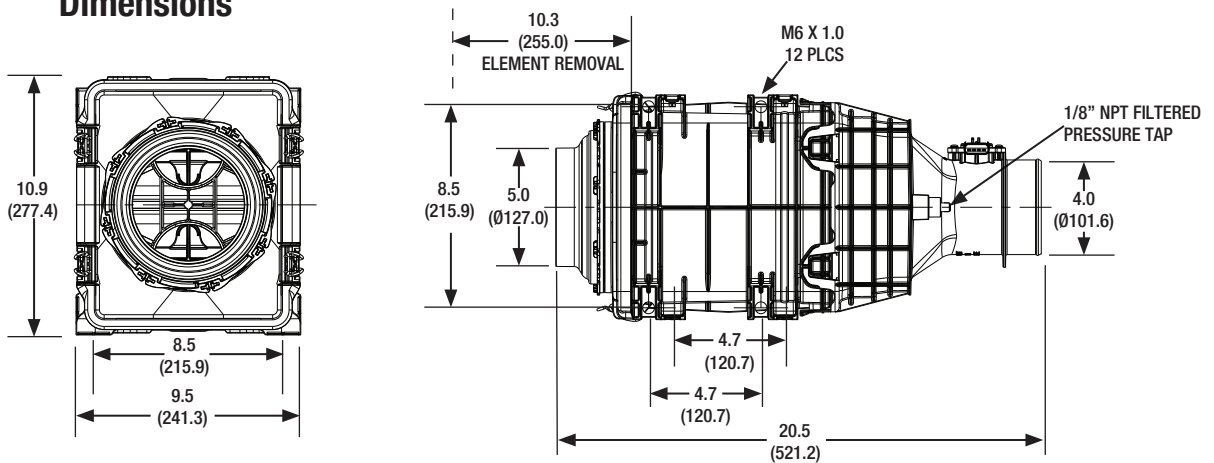

All dimensions are in inches (millimeters)

Ordering Information

Air Cleaners	
Part Number	Description
AH55592	Direct Flow -Remote Pre-Cleaner -Front Inlet -With MAF Sensor

Service Parts	
Part Number	Description
AF55020	Primary Element
AF55312	Secondary Element
SP1054	Mass Airflow Sensor
SP1060	M6 Mounting Clips
SP1042	Front Service Cover

Optional Accessories	
Part Number	Description
3316658S	4" Band Clamp
3316660S	5" Band Clamp
3316608S	4" Hump Hose
3316610S	5" Hump Hose
3316568S	4" 90° Elbow
3316570S	5" 90° Elbow
3316618S	5" to 4" Hump Hose Reducer
3946329S	Restriction Indicator

Additional sizes/shapes may be available. Refer to the Cummins Filtration catalog or website.

Performance

System Restriction vs Flow Rate

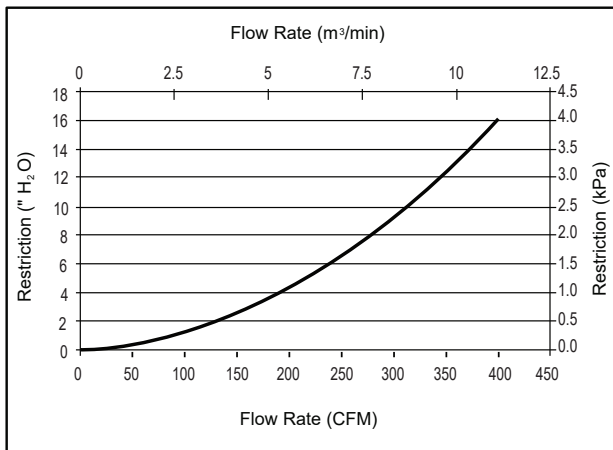

System Capacity vs Flow Rate

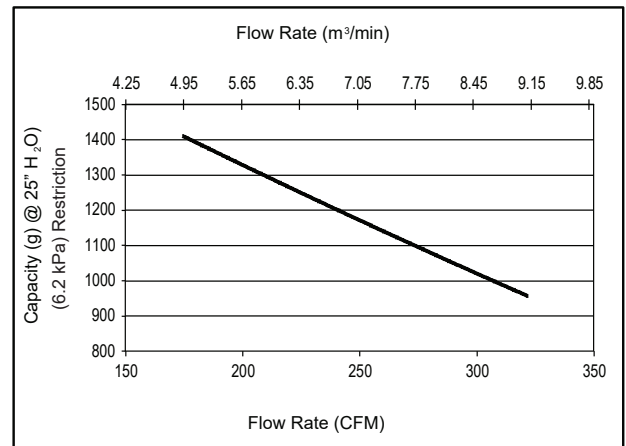

Restriction		Flow Rate		Typical Capacity at 25" H ₂ O (6.2 kPa) of Terminal Restriction Non Aspirated (g)
in H ₂ O	kPa	CFM	m³/min	
4	1.0	188	5.3	1366
6	1.5	236	6.6	1218
8	2.0	278	7.8	1090
10	2.5	314	8.9	981
12	3.0	346	9.8	889

ISO Fine Dust
1.0 g/m³ Feed Rate
25" H₂O (6.2 kPa)
Terminal Restriction
per ISO 5011

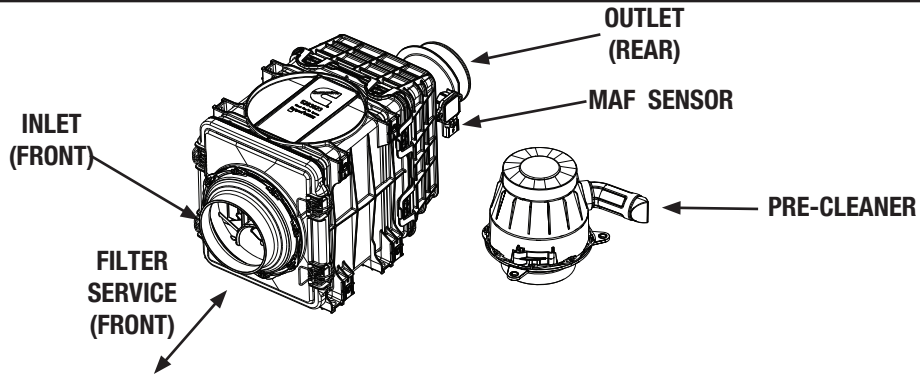

Specifications

Specification	AK55681
Length, Overall	20.5" (521.0 mm)
Width, Overall	9.5" (241.3 mm)
Height, Overall	10.9" (277.4 mm)
Flow, Min. at 2" H ₂ O (0.5 kPa) Restriction	133 CFM (3.8 m ³ /min)
Flow, Max. at 12" H ₂ O (3.0 kPa) Restriction	308 CFM (8.7 m ³ /min)
Secondary Element	Yes
Housing Material	Glass-filled Polyamide
Pre-Cleaner	Remote
Inlet	Straight, 5.0" (Ø127.0 mm)
Outlet	Straight, 4.00" (Ø101.6 mm)
Filter Efficiency	≥ 99.90% per ISO 5011

Specifications Subject to change without notice.

Dust Holding Capacity per Flow Rate

Specification	Non Aspirated	
	CFM	m ³ /min
Maximum Flow for 10 g/CFM (357.1 g/m ³ /min)	298*	8.4*
Maximum Flow for 25 g/CFM (892.9 g/m ³ /min)	152	4.3

*Indicates maximum recommended flow rate.

Dimensions

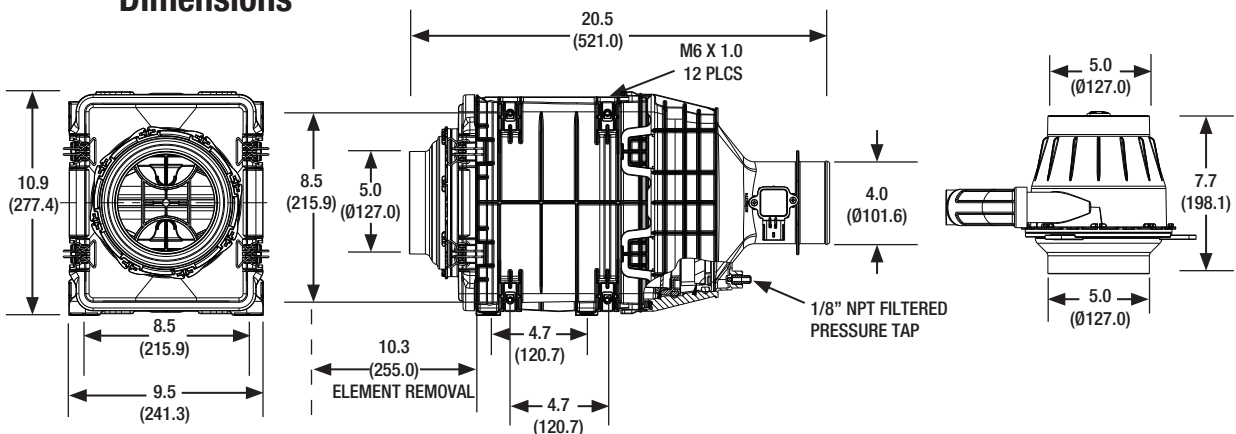

All dimensions are in inches (millimeters)

Ordering Information

Air Cleaners		Service Parts		Optional Accessories	
Part Number	Description	Part Number	Description	Part Number	Description
AK55681	Direct Flow -Remote Pre-Cleaner -Front Inlet -With MAF Sensor	AF55020	Primary Element	3316658S	4" Band Clamp
		AF55312	Secondary Element	3316660S	5" Band Clamp
		SP1054	Mass Airflow Sensor	3316608S	4" Hump Hose
		AP15903	Pre-Cleaner	3316610S	5" Hump Hose
		SP1048	Dust Ejection Valve (DEV)	3316568S	4" 90° Elbow
		SP1060	M6 Mounting Clips	3316570S	5" 90° Elbow
		SP1042	Front Service Cover	3316618S	5" to 4" Hump Hose Reducer
				3946329S	Restriction Indicator

Additional sizes/shapes may be available.
Refer to the Cummins Filtration catalog or website.

Performance

System Restriction vs Flow Rate

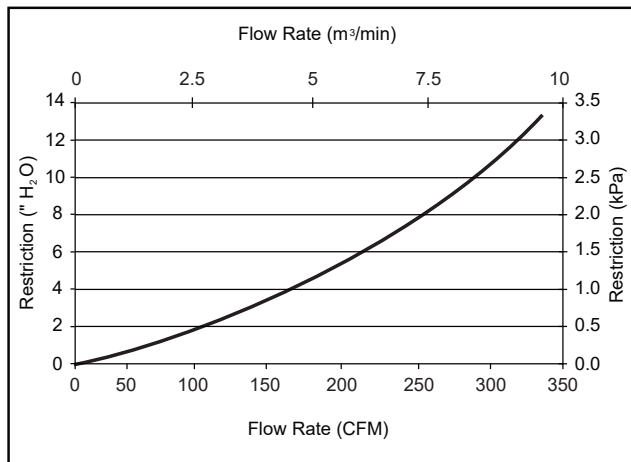

System Capacity vs Flow Rate

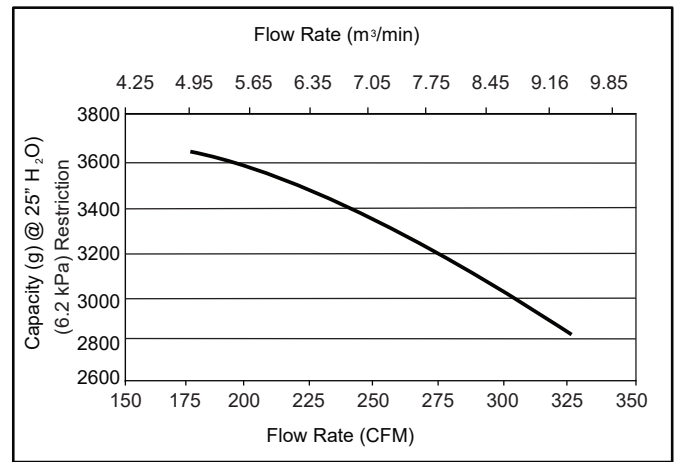

Note: These curves represent test data with limited data replicates. Data also reflects Pre-Cleaner as integrated.

Restriction		Flow Rate		Typical Capacity at 25" H ₂ O (6.2 kPa) of Terminal Restriction	Typical Capacity at 30" H ₂ O (6.2 kPa) of Terminal Restriction
in H ₂ O	kPa	CFM	m³/min	Non Aspirated (g)	Non Aspirated (g)
4	1.0	170	4.8	3650	3730
6	1.5	213	6.0	3480	3590
8	2.0	248	7.0	3310	3500
10	2.5	280	7.9	3120	3440
12	3.0	308	8.7	2920	3390

ISO Coarse Dust
2.0 g/m³ Feed Rate
25" H₂O (6.2 kPa)
Terminal Restriction
per ISO 5011

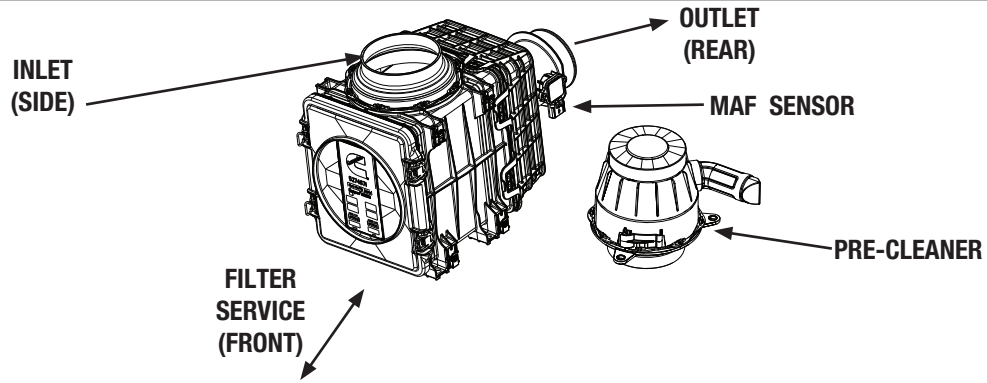

Specifications

Specification	AK55682
Length, Overall	18.4" (469.2 mm)
Width, Overall	9.5" (241.3 mm)
Height, Overall	12.7" (322.8 mm)
Flow, Min. at 2" H ₂ O (0.5 kPa) Restriction	120 CFM (3.3 m ³ /min)
Flow, Max. at 12" H ₂ O (3.0 kPa) Restriction	308 CFM (8.7 m ³ /min)
Secondary Element	Yes
Housing Material	Glass-filled Polyamide
Pre-Cleaner	Remote
Inlet	90° to Outlet, 5.0" (Ø127.0 mm)
Outlet	Straight, 4.0" (Ø101.6 mm)
Filter Efficiency	≥ 99.90% per ISO 5011

Specifications Subject to change without notice.

Dust Holding Capacity per Flow Rate

Specification	Non Aspirated	
	CFM	m ³ /min
Maximum Flow for 10 g/CFM (357.1 g/m ³ /min)	296*	8.4*
Maximum Flow for 25 g/CFM (892.9 g/m ³ /min)	152	4.3

*Indicates maximum recommended flow rate.

Dimensions

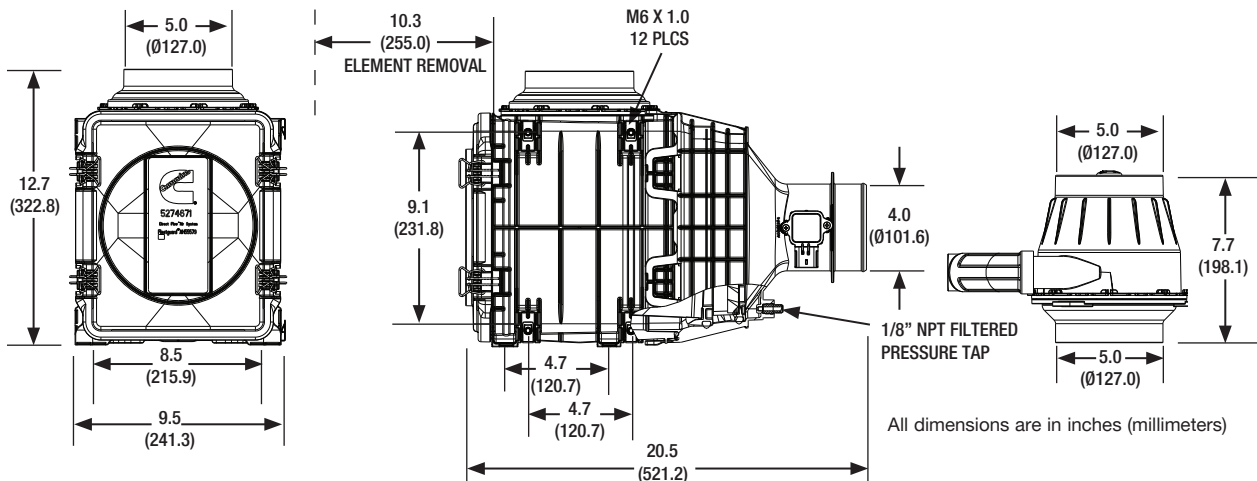

All dimensions are in inches (millimeters)

Ordering Information

Air Cleaners	
Part Number	Description
AK55682	Direct Flow -Remote Pre-Cleaner -Front Inlet -With MAF Sensor

Service Parts	
Part Number	Description
AF55020	Primary Element
AF55312	Secondary Element
AP15903	Pre-Cleaner
SP1048	Dust Ejection Valve (DEV)
SP1060	M6 Mounting Clips
SP1041	Front Service Cover

Optional Accessories	
Part Number	Description
3316658S	4" Band Clamp
3316660S	5" Band Clamp
3316608S	4" Hump Hose
3316610S	5" Hump Hose
3316568S	4" 90° Elbow
3316570S	5" 90° Elbow
3316618S	5" to 4" Hump Hose Reducer
3946329S	Restriction Indicator

Additional sizes/shapes may be available.
Refer to the Cummins Filtration catalog or website.

Performance

System Restriction vs Flow Rate

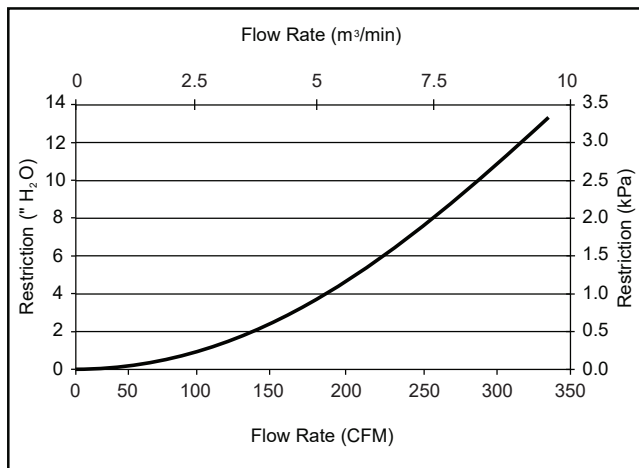

System Capacity vs Flow Rate

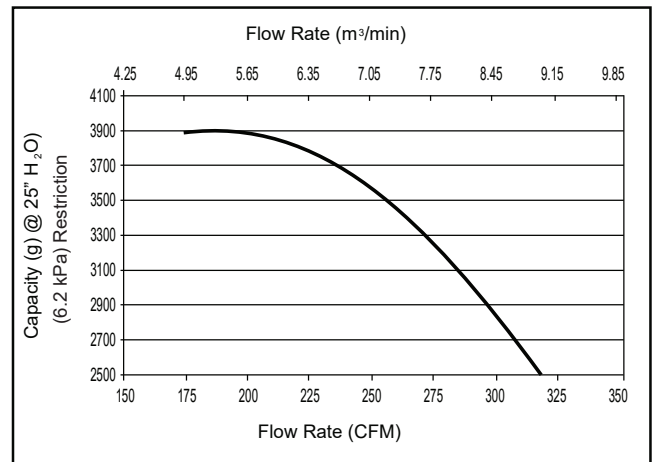

Note: Data reflects Pre-Cleaner as integrated.

Restriction		Flow Rate		Typical Capacity at 25" H ₂ O (6.2 kPa) of Terminal Restriction	Typical Capacity at 30" H ₂ O (6.2 kPa) of Terminal Restriction
in H ₂ O	kPa	CFM	m ³ /min	Non Aspirated (g)	Non Aspirated (g)
4	1.0	165	4.6	3850	3970
6	1.5	210	5.9	3840	3960
8	2.0	248	7.0	3580	3790
10	2.5	280	7.9	3200	3520
12	3.0	308	8.7	2730	3200

ISO Coarse Dust
2.0 g/m³ Feed Rate
25" H₂O (6.2 kPa)
Terminal Restriction
per ISO 5011

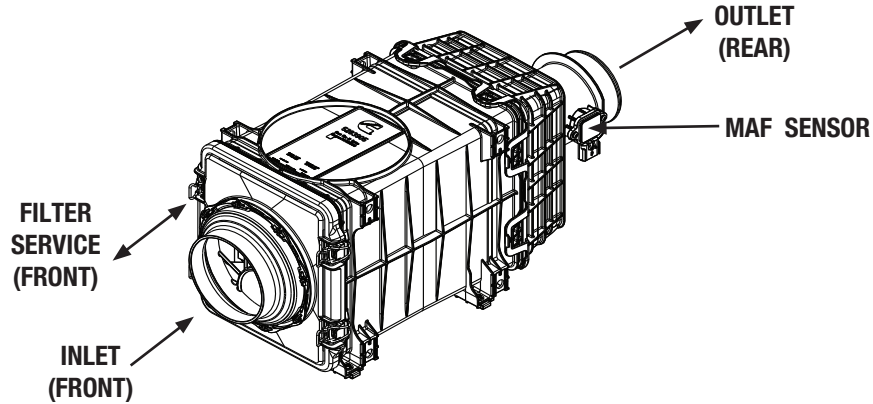

Specifications

Specifications	AH55593
Length, Overall	24.5" (622.3 mm)
Width, Overall	9.5" (241.3 mm)
Height, Overall	10.92" (277.4 mm)
Flow, MIN. AT 2" H ₂ O (0.5 kPa) Restriction	127 CFM (3.6 m ³ /min)
Flow, MAX. AT 12" H ₂ O (3.0 kPa) Restriction	356 CFM (10.1 m ³ /min)
Secondary Element	Yes
Housing Material	Glass-filled Polyamide
Pre-Cleaner	No
Inlet Transition	Yes
Filter Efficiency	≥ 99.90% per ISO 5011

Specifications Subject to change without notice.

Dust Holding Capacity per Flow Rate

Specification	Non Aspirated	
	CFM	m ³ /min
Maximum Flow for 10 g/CFM (357.1 g/m ³ /min)	204.8	5.8
Maximum Flow for 25 g/CFM (892.9 g/m ³ /min)	N/A*	N/A*

* Requires pre-cleaner (optional)

Dimensions

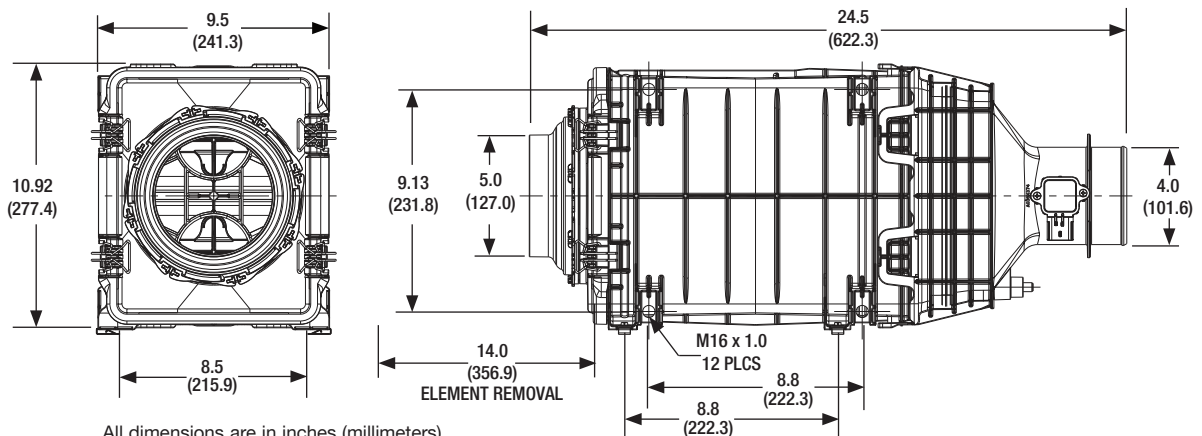

All dimensions are in inches (millimeters)

Ordering Information

Air Cleaners	
Part Number	Description
AH55593	Direct Flow -Front Inlet -with MAF Sensor

Service Parts	
Part Number	Description
AF55021	Primary Element
AF55312	Secondary Element
SP1042	Front Service Cover
AP15909	Pre-Cleaner
SP1048	Dust Ejection Valve (DEV)
SP1060	M6 Mounting clips

Optional Accessories	
Part Number	Description
3316658S	4" Band Clamp
3316660S	5" Band Clamp
3316608S	4" Hump Hose
3316610S	5" Hump Hose
3316568S	4" 90° Elbow
3316570S	5" 90° Elbow
3316618S	5" to 4" Hump Hose Reducer
3946329S	Restriction Indicator

Additional sizes/shapes may be available.
Refer to the Cummins Filtration catalog or website.

Performance

System Restriction vs Flow Rate

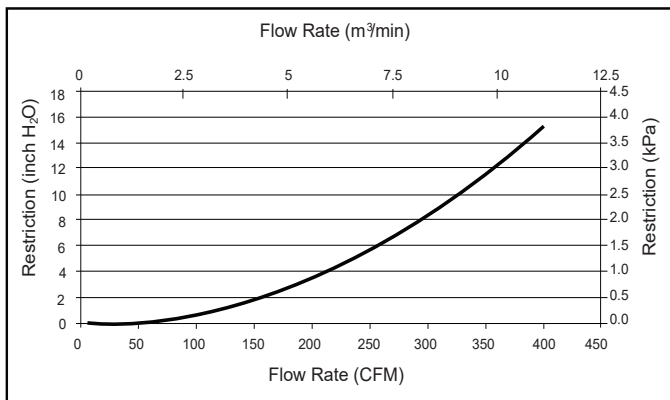

System Capacity vs Flow Rate

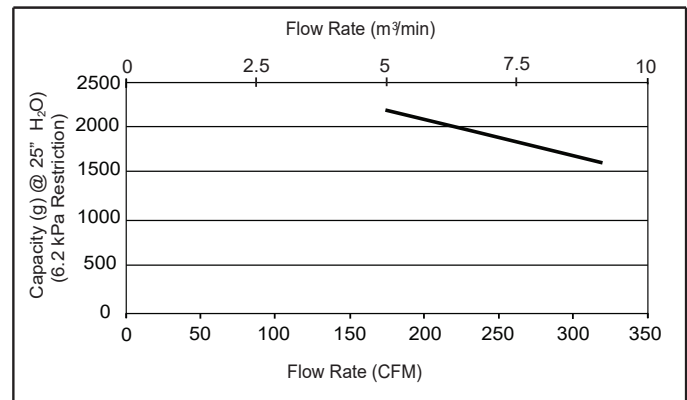

Restriction		Flow Rate		Typical Capacity at 25" H ₂ O (6.2 kPa) of Terminal Restriction
in H ₂ O	kPa	CFM	m ³ /min	Non Aspirated (g)
4.0	1.0	191	5.40	2097.6
6.0	1.5	240	6.80	1914.7
8.0	2.0	284	8.05	1763.9
10.0	2.5	323	9.14	1641.1
12.0	3.0	356	10.07	1542.7

ISO Fine Dust
1.0 g/m³ Feed Rate
25" H₂O (6.2 kPa)
Terminal Restriction
per ISO 5011

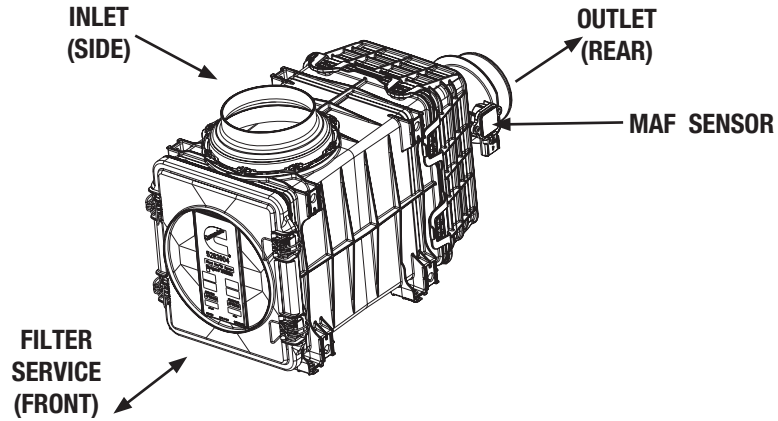

Specifications

Specifications	AH55584
Length, Overall	22.4" (570.8 mm)
Width, Overall	9.50" (241.3 mm)
Height, Overall	12.70" (322.8 mm)
Flow, MIN. AT 2" H ₂ O (0.5 kPa) Restriction	130.8 CFM (3.7 m ³ /min)
Flow, MAX. AT 12" H ₂ O (3.0 kPa) Restriction	330 CFM (9.3 m ³ /min)
Secondary Element	Yes
Housing Material	Glass-filled Polyamide
Pre-Cleaner	No
Filter Efficiency	≥ 99.90% per ISO 5011

Specifications Subject to change without notice.

Dust Holding Capacity per Flow Rate

Specification	Non Aspirated	
	CFM	m ³ /min
Maximum Flow for 10 g/CFM (357.1 g/m ³ /min)	214.6	6.1
Maximum Flow for 25 g/CFM (892.9 g/m ³ /min)	N/A*	N/A*

* Requires pre-cleaner (optional)

Dimensions

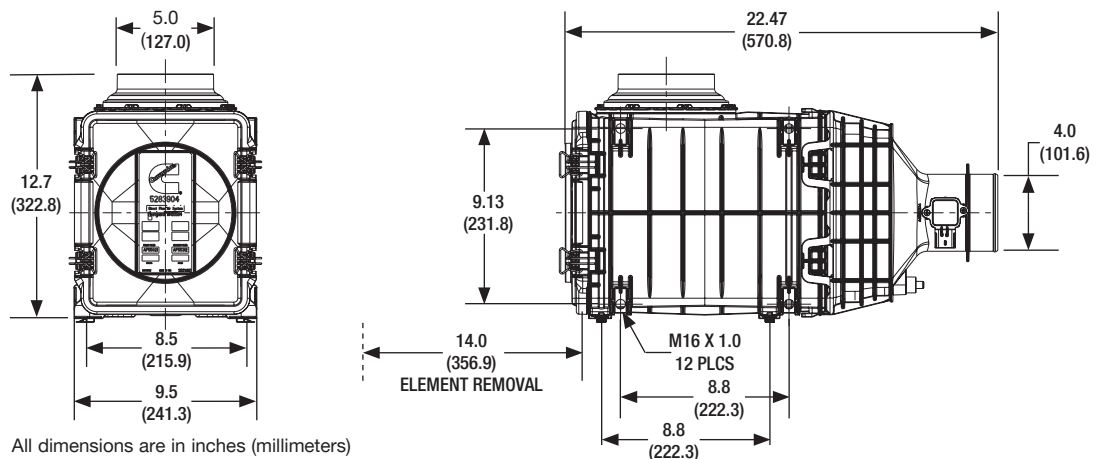

All dimensions are in inches (millimeters)

Ordering Information

Air Cleaners	
Part Number	Description
AH55584	Direct Flow -Side Inlet -with MAF Sensor

Service Parts	
Part Number	Description
AF55021	Primary Element
AF55312	Secondary Element
SP1041	Front Service Cover
AP15909	Pre-Cleaner
SP1048	Dust Ejection Valve (DEV)
SP1060	M6 Mounting clips

Optional Accessories	
Part Number	Description
3316658S	4" Band Clamp
3316660S	5" Band Clamp
3316608S	4" Hump Hose
3316610S	5" Hump Hose
3316568S	4" 90° Elbow
3316570S	5" 90° Elbow
3316618S	5" to 4" Hump Hose Reducer
3946329S	Restriction Indicator

Additional sizes/shapes may be available.
Refer to the Cummins Filtration catalog or website.

Performance

System Restriction vs Flow Rate

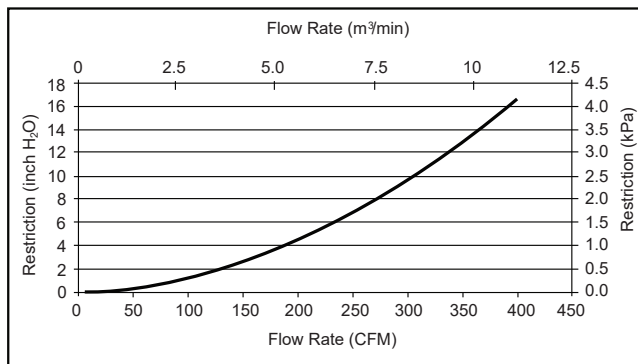

System Capacity vs Flow Rate

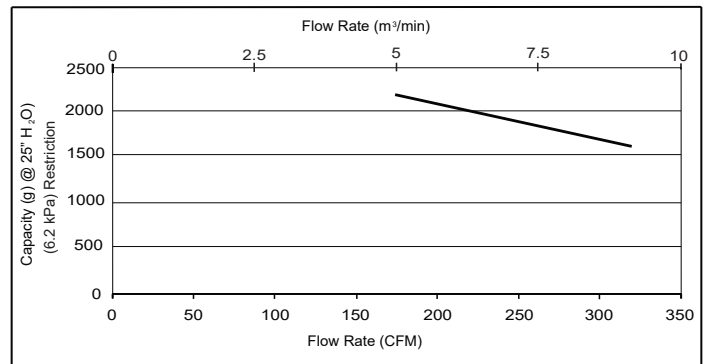

Restriction		Flow Rate		Typical Capacity at 25" H ₂ O (6.2 kPa) of Terminal Restriction
in H ₂ O	kPa	CFM	m³/min	Non Aspirated (g)
4.0	1.0	190	5.37	2258.5
6.0	1.5	238	6.73	2064.8
8.0	2.0	280	7.94	1866.9
10.0	2.5	318	9.01	1673.4
12.0	3.0	350	9.92	1491.9

ISO Fine Dust
1.0 g/m³ Feed Rate
25" H₂O (6.2 kPa)
Terminal Restriction
per ISO 5011

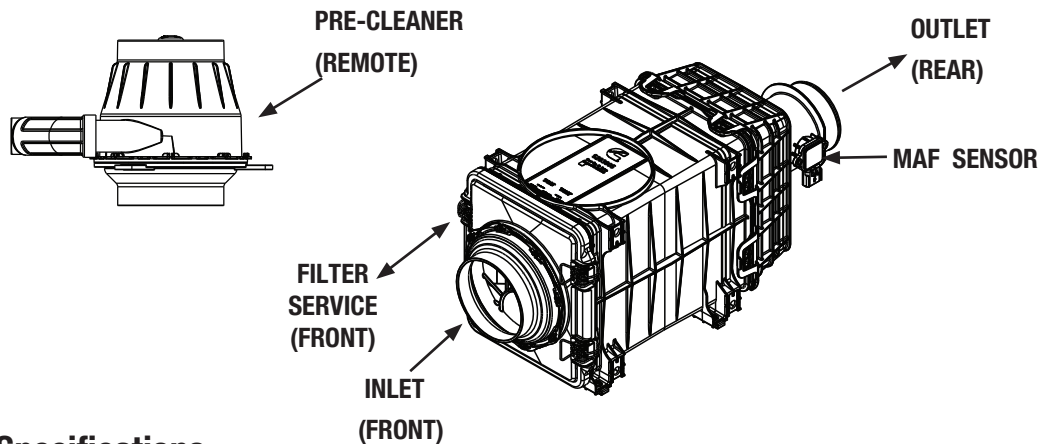

Specifications

Specifications	AK55683
Length, Overall	24.5" (622.3 mm)
Width, Overall	9.5" (241.3 mm)
Height, Overall	10.92" (277.4 mm)
Flow, MIN. AT 2" H ₂ O (0.5 kPa) Restriction	120 CFM (3.4 m ³ /min)
Flow, MAX. AT 12" H ₂ O (3.0 kPa) Restriction	315 CFM (8.9 m ³ /min)
Secondary Element	Yes
Housing Material	Glass-filled Polyamide
Pre-Cleaner	Remote
Filter Efficiency	≥ 99.90% per ISO 5011

Specifications Subject to change without notice.

Dust Holding Capacity per Flow Rate

Specification	Non Aspirated	
	CFM	m ³ /min
Maximum Flow for 10 g/CFM (357.1 g/m ³ /min)	315*	8.9*
Maximum Flow for 25 g/CFM (892.9 g/m ³ /min)	195.4	5.5

* Indicates maximum recommended flow rate.

Dimensions

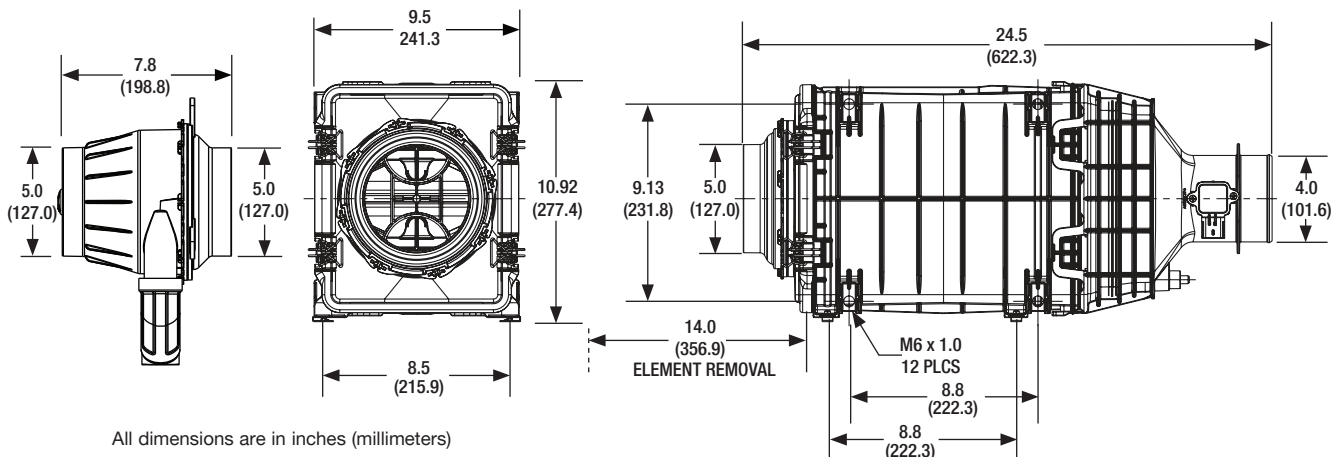

All dimensions are in inches (millimeters)

Ordering Information

Air Cleaners	
Part Number	Description
AK55683	Direct Flow -Front Inlet -Remote Pre-Cleaner -With MAF Sensor

Service Parts	
Part Number	Description
AF55021	Primary Element
AF55312	Secondary Element
SP1042	Front Service Cover
AP15903	Pre-Cleaner
SP1048	Dust Ejection Valve (DEV)
SP1060	M6 Mounting clips

Optional Accessories	
Part Number	Description
3316658S	4" Band Clamp
3316660S	5" Band Clamp
3316608S	4" Hump Hose
3316610S	5" Hump Hose
3316568S	4" 90° Elbow
3316570S	5" 90° Elbow
3316618S	5" to 4" Hump Hose Reducer
3946329S	Restriction Indicator

Additional sizes/shapes may be available.
Refer to the Cummins Filtration catalog or website.

Performance

System Restriction vs Flow Rate

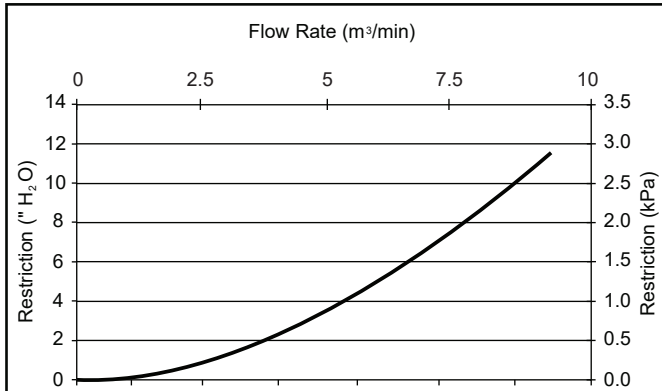

System Capacity vs Flow Rate

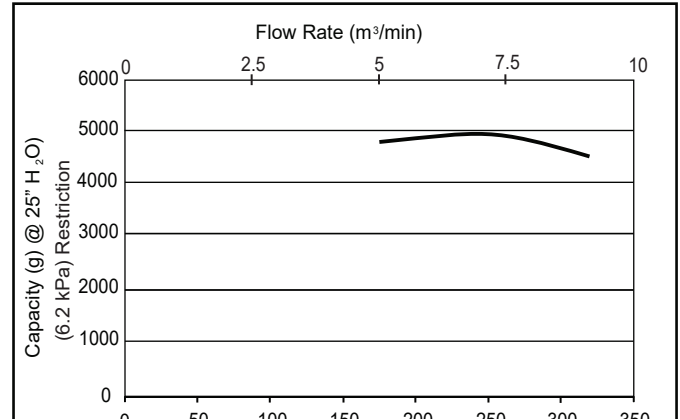

Restriction		Flow Rate		Typical Capacity at 25" H ₂ O (6.2 kPa) of Terminal Restriction
in H ₂ O	kPa	CFM	m³/min	Non Aspirated (g)
4.0	1.0	175	4.96	5060
6.0	1.5	222	6.29	5070
8.0	2.0	255	7.22	5060
10.0	2.5	288	8.16	5040
12.0	3.0	315	8.92	5020

ISO Course Dust
2.0 g/m³ Feed Rate
25" H₂O (6.2 kPa)
Terminal Restriction
per ISO 5011

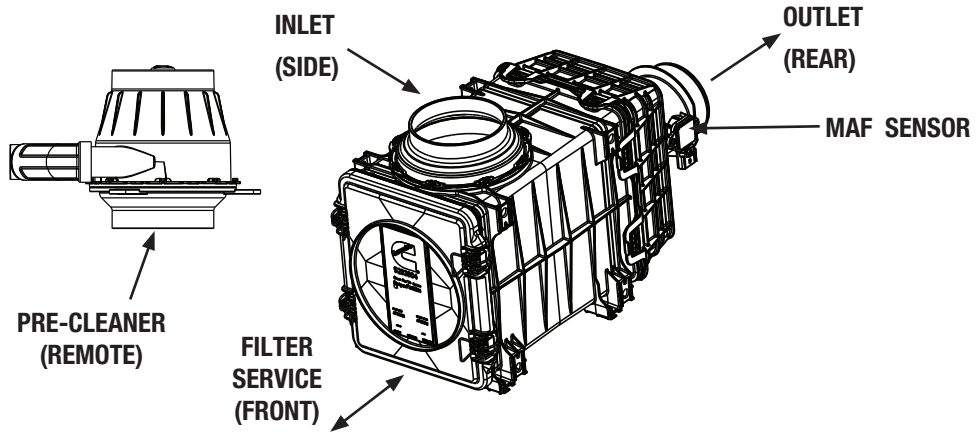

Specifications

Specifications	AK55684
Length, Overall	22.5" (570.8 mm)
Width, Overall	9.5" (241.3 mm)
Height, Overall	12.7" (322.8 mm)
Flow, MIN. AT 2" H ₂ O (0.5 kPa) Restriction	117.7 CFM (3.3 m ³ /min)
Flow, MAX. AT 12" H ₂ O (3.0 kPa) Restriction	311 CFM (8.8 m ³ /min)
Secondary Element	Yes
Housing Material	Glass-filled Polyamide
Pre-Cleaner	Remote
Filter Efficiency	≥ 99.90% per ISO 5011

Specifications Subject to change without notice.

Dust Holding Capacity per Flow Rate

Specification	Non Aspirated	
	CFM	m ³ /min
Maximum Flow for 10 g/CFM (357.1 g/m ³ /min)	311*	8.8*
Maximum Flow for 25 g/CFM (892.9 g/m ³ /min)	212.5	6.0

* Indicates maximum recommended flow rate.

Dimensions

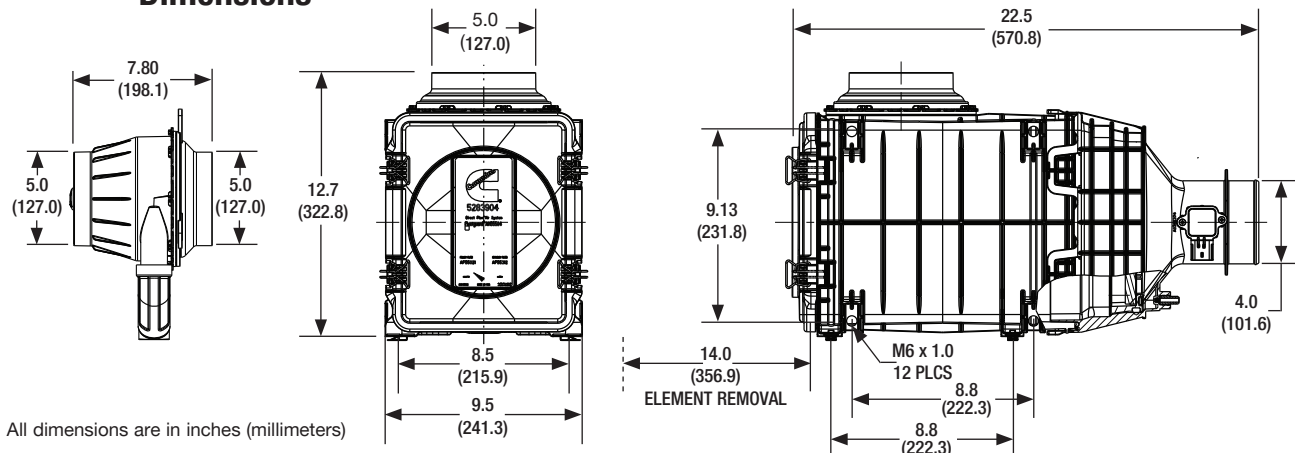

All dimensions are in inches (millimeters)

Ordering Information

Air Cleaners	
Part Number	Description
AK55684	Direct Flow -Side Inlet -Remote Pre-Cleaner -With MAF Sensor

Service Parts	
Part Number	Description
AF55021	Primary Element
AF55312	Secondary Element
SP1041	Front Service Cover
AP15903	Pre-Cleaner
SP1048	Dust Ejection Valve (DEV)
SP1060	M6 Mounting clips

Optional Accessories	
Part Number	Description
3316658S	4" Band Clamp
3316660S	5" Band Clamp
3316608S	4" Hump Hose
3316610S	5" Hump Hose
3316568S	4" 90° Elbow
3316570S	5" 90° Elbow
3316618S	5" to 4" Hump Hose Reducer
3946329S	Restriction Indicator

Additional sizes/shapes may be available. Refer to the Cummins Filtration catalog or website.

Performance

System Restriction vs Flow Rate

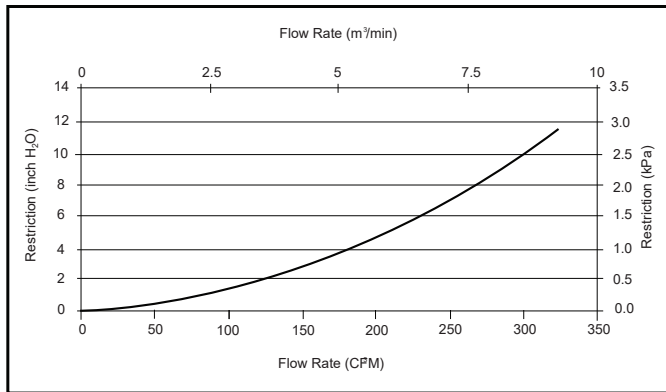

System Capacity vs Flow Rate

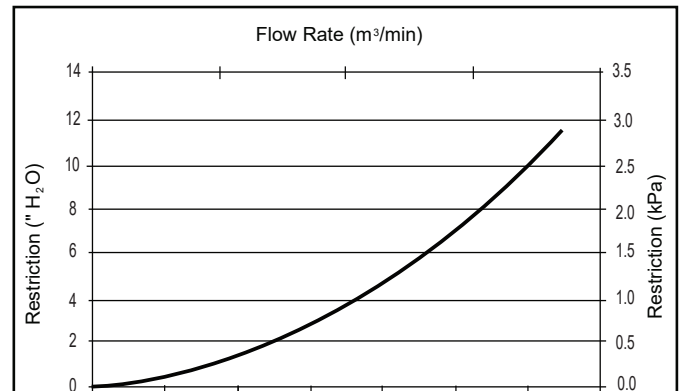

Restriction		Flow Rate		Typical Capacity at 25" H ₂ O (6.2 kPa) of Terminal Restriction
in H ₂ O	kPa	CFM	m³/min	Non Aspirated (g)
4.0	1.0	170	4.81	5720
6.0	1.5	213	6.03	5310
8.0	2.0	252	7.14	5040
10.0	2.5	282	7.99	4890
12.0	3.0	311	8.81	4810

ISO Coarse Dust
2.0 g/m³ Feed Rate
25" H₂O (6.2 kPa)
Terminal Restriction
per ISO 5011

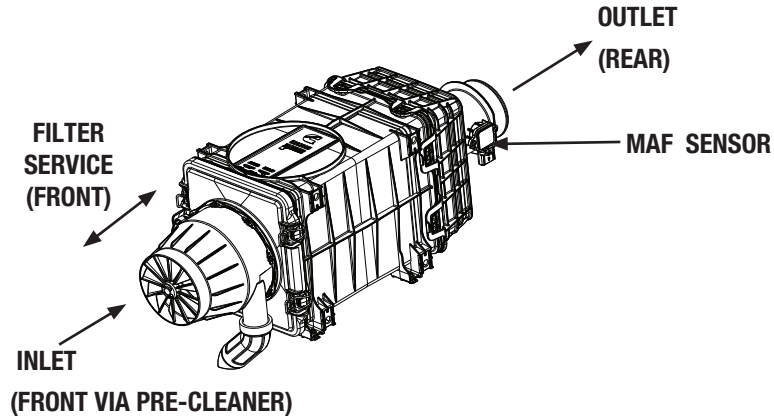

Specifications

Specifications	AH55587
Length, Overall	28.4" (722.3 mm)
Width, Overall	9.5" (241.3 mm)
Height, Overall	10.9" (277.4 mm)
Flow, MIN. AT 2" H ₂ O (0.5 kPa) Restriction	120 CFM (3.4 m ³ /min)
Flow, MAX. AT 12" H ₂ O (3.0 kPa) Restriction	315 CFM (8.9 m ³ /min)
Secondary Element	Yes
Housing Material	Glass-filled Polyamide
Pre-Cleaner	Integrated
Filter Efficiency	≥ 99.90% per ISO 5011

Specifications Subject to change without notice.

Dust Holding Capacity per Flow Rate

Specification	Non Aspirated	
	CFM	m ³ /min
Maximum Flow for 10 g/CFM (357.1 g/m ³ /min)	315*	8.9*
Maximum Flow for 25 g/CFM (892.9 g/m ³ /min)	195.4	5.5

* Indicates maximum recommended flow rate.

Dimensions

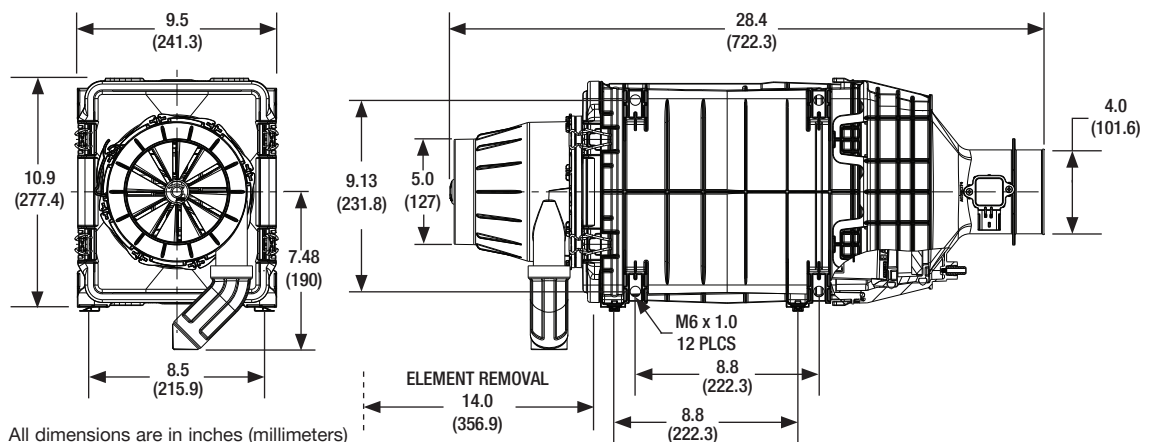

Ordering Information

Air Cleaners	
Part Number	Description
AH55587	Direct Flow -Front Inlet -Integrated Pre-Cleaner -With MAF Sensor

Service Parts	
Part Number	Description
AF55021	Primary Element
AF55312	Secondary Element
SP1042	Front Service Cover
AP15909	Pre-Cleaner
SP1048	Dust Ejection Valve (DEV)
SP1060	M6 Mounting clips

Optional Accessories	
Part Number	Description
3316658S	4" Band Clamp
3316660S	5" Band Clamp
3316608S	4" Hump Hose
3316610S	5" Hump Hose
3316568S	4" 90° Elbow
3316570S	5" 90° Elbow
3316618S	5" to 4" Hump Hose Reducer
3946329S	Restriction Indicator

Additional sizes/shapes may be available.
Refer to the Cummins Filtration catalog or website.

Performance

System Restriction vs Flow Rate

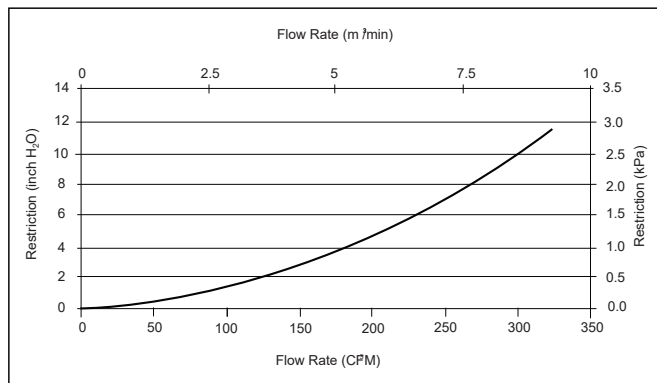

System Capacity vs Flow Rate

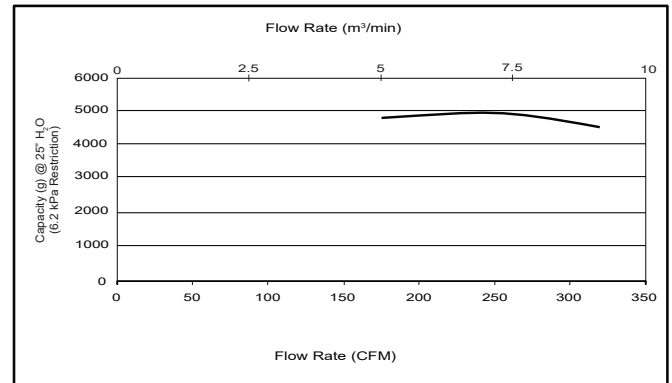

Restriction		Flow Rate		Typical Capacity at 25" H ₂ O (6.2 kPa) of Terminal Restriction Non Aspirated (g)
in H ₂ O	kPa	CFM	m³/min	
4.0	1.0	175	4.96	5060
6.0	1.5	222	6.29	5070
8.0	2.0	255	7.22	5060
10.0	2.5	288	8.16	5040
12.0	3.0	315	8.92	5020

ISO Coarse Dust
2.0 g/m³ Feed Rate
25" H₂O (6.2 kPa)
Terminal Restriction
per ISO 5011

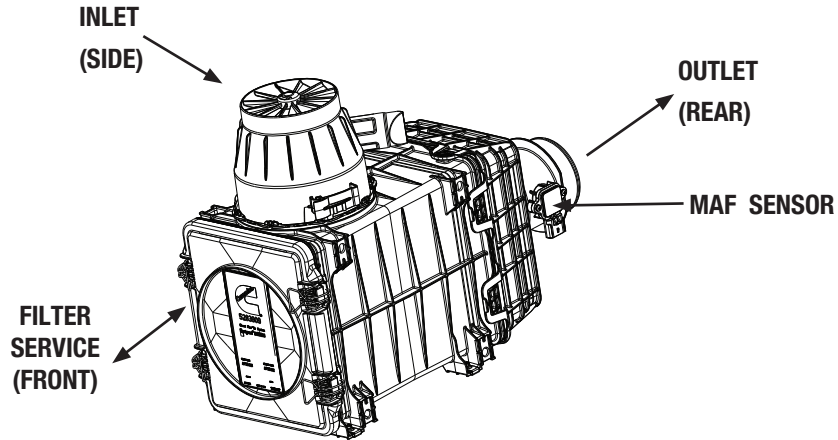

Specifications

Specifications	AH55588
Length, Overall	22.5" (570.8 mm)
Width, Overall	9.50" (241.3 mm)
Height, Overall	16.6" (422.5 mm)
Flow, MIN. AT 2" H ₂ O (0.5 kPa) Restriction	117.68 CFM (3.3 m ³ /min)
Flow, MAX. AT 12" H ₂ O (3.0 kPa) Restriction	311 CFM (8.8 m ³ /min)
Secondary Element	Yes
Housing Material	Glass-filled Polyamide
Pre-Cleaner	Integrated
Filter Efficiency	≥ 99.90% per ISO 5011

Specifications Subject to change without notice.

Dust Holding Capacity per Flow Rate

Specification	Non Aspirated	
	CFM	m ³ /min
Maximum Flow for 10 g/CFM (357.1 g/m ³ /min)	311*	8.8*
Maximum Flow for 25 g/CFM (892.9 g/m ³ /min)	212.5	6.0

* Indicates maximum recommended flow rate.

Dimensions

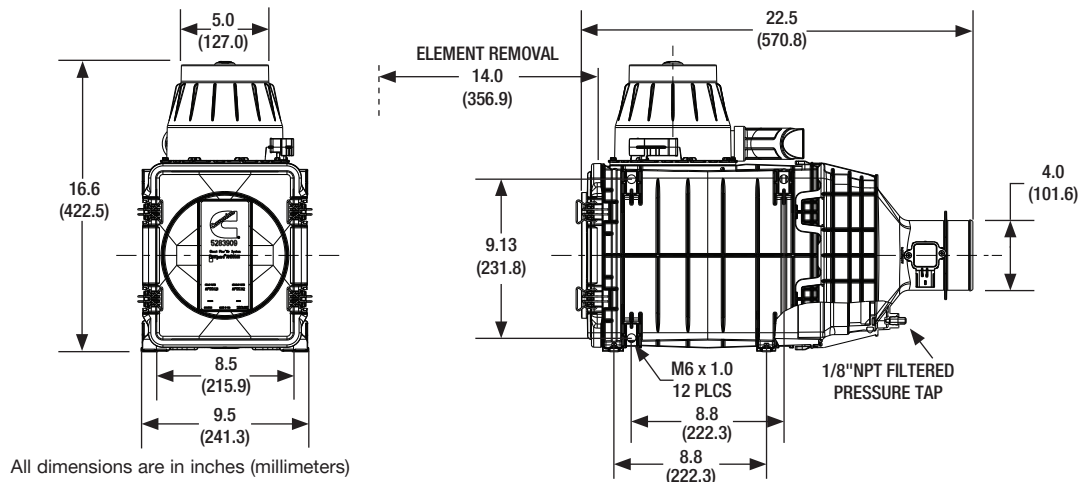

Ordering Information

Air Cleaners	
Part Number	Description
AH55588	Direct Flow -Side Inlet -Integrated Pre-Cleaner -With MAF Sensor

Service Parts	
Part Number	Description
AF55021	Primary Element
AF55312	Secondary Element
SP1041	Front Service Cover
AP15909	Pre-Cleaner
SP1048	Dust Ejection Valve (DEV)
SP1060	M6 Mounting clips

Optional Accessories	
Part Number	Description
3316658S	4" Band Clamp
3316660S	5" Band Clamp
3316608S	4" Hump Hose
3316610S	5" Hump Hose
3316568S	4" 90° Elbow
3316570S	5" 90° Elbow
3316618S	5" to 4" Hump Hose Reducer
3946329S	Restriction Indicator

Additional sizes/shapes may be available.
Refer to the Cummins Filtration catalog or website.

Performance

System Restriction vs Flow Rate

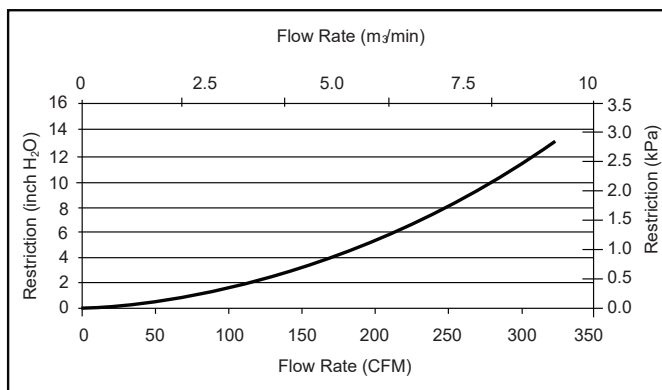

System Capacity vs Flow Rate

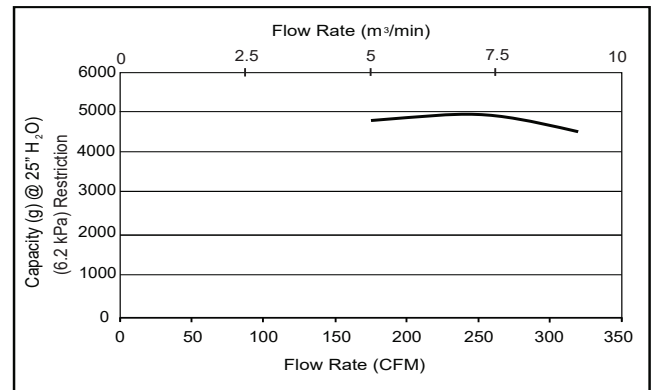

Restriction		Flow Rate		Typical Capacity at 25" H ₂ O (6.2 kPa) of Terminal Restriction Non Aspirated (g)
in H ₂ O	kPa	CFM	m³/min	
4.0	1.0	170	4.81	5730
6.0	1.5	213	6.03	5600
8.0	2.0	252	7.14	5500
10.0	2.5	282	7.99	5440
12.0	3.0	311	8.81	5380

ISO Coarse Dust
2.0 g/m³ Feed Rate
25" H₂O (6.2 kPa)
Terminal Restriction
per ISO 5011

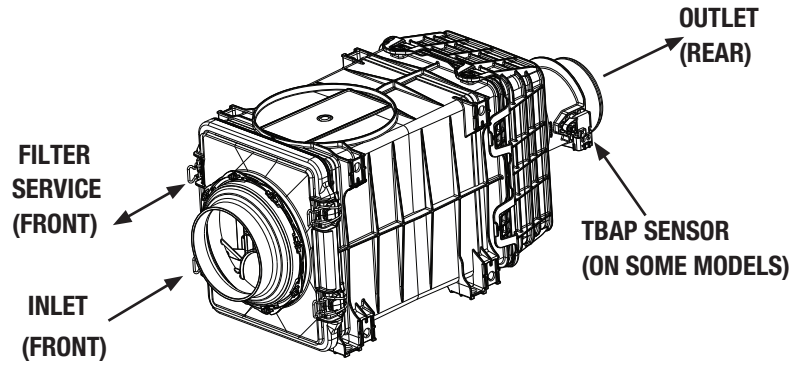

Specifications

Specifications	AH55643
Length, Overall	24.5" (622.8 mm)
Width, Overall	10.9" (277.4 mm)
Height, Overall	9.5" (241.3 mm)
Flow, MIN. AT 2" H ₂ O (0.5 kPa) Restriction	180 CFM (5.0 m ³ /min)
Flow, MAX. AT 12" H ₂ O (3.0 kPa) Restriction	480 CFM (13.6 m ³ /min)
Secondary Element	Yes
Housing Material	Glass-filled Polyamide
Pre-Cleaner	No
Inlet	Straight 5.0 (127 mm)
Outlet	Straight 4.0" (101.6 mm)
Filter Efficiency	≥ 99.90% per ISO 5011

Specifications Subject to change without notice.

Dust Holding Capacity per Flow Rate

Specification	Non Aspirated	
	CFM	m ³ /min
Maximum Flow for 10 g/CFM (357.1 g/m ³ /min)	212	6.0
Maximum Flow for 25 g/CFM (892.9 g/m ³ /min)	N/A*	N/A*

* Requires pre-cleaner (optional)

Dimensions

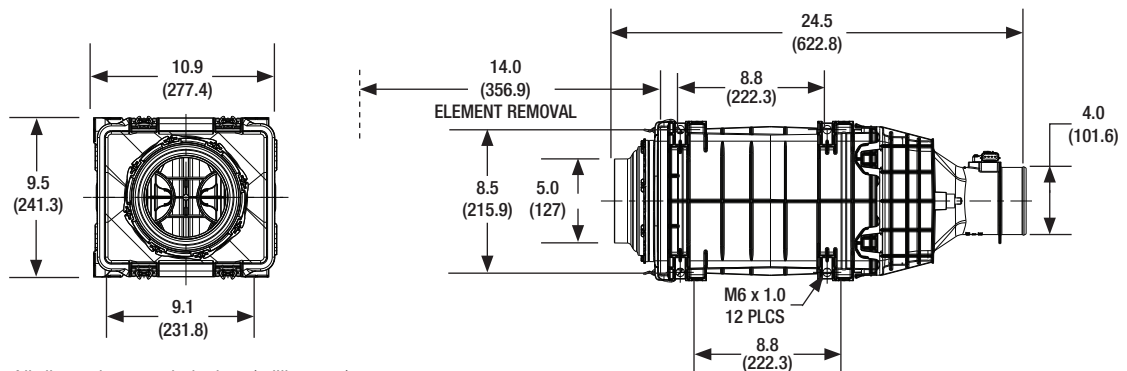

All dimensions are in inches (millimeters)

Ordering Information

Air Cleaners	
Part Number	Description
AH55643	Direct Flow -Front Inlet -With TBAP Sensor

Service Parts	
Part Number	Description
AF55021	Primary Element
AF55320	Secondary Element
SP1042	Front Service Cover
SP1060	M6 Mounting clips

Optional Accessories	
Part Number	Description
3316658S	4" Band Clamp
3316660S	5" Band Clamp
3316608S	4" Hump Hose
3316610S	5" Hump Hose
3316568S	4" 90° Elbow
3316570S	5" 90° Elbow
3316618S	5" to 4" Hump Hose Reducer
3946329S	Restriction Indicator

Additional sizes/shapes may be available.
Refer to the Cummins Filtration catalog or website.

Performance

System Restriction vs Flow Rate

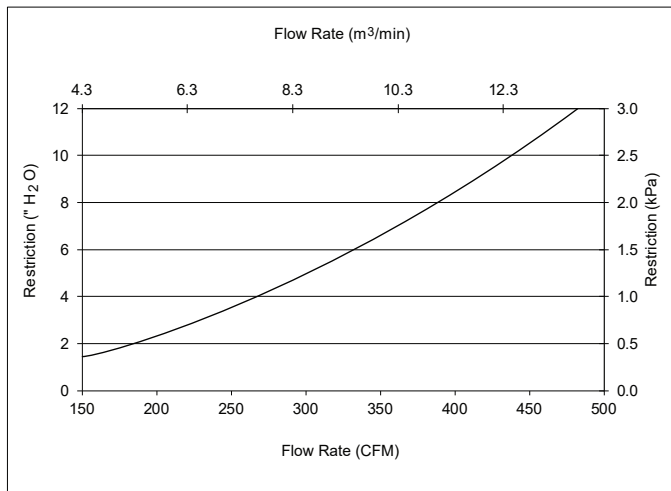

System Capacity vs Flow Rate

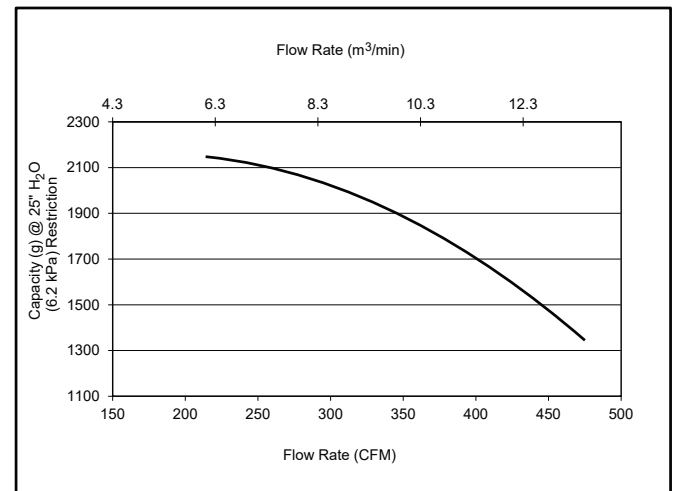

Restriction		Flow Rate		Typical Capacity at 25" H ₂ O (6.2 kPa) of Terminal Restriction
in H ₂ O	kPa	CFM	m³/min	Non Aspirated (g)
4.0	1.0	268	7.6	2080
6.0	1.5	332	9.4	1940
8.0	2.0	390	11.0	1750
10.0	2.5	440	12.5	1525
12.0	3.0	482	13.6	1325

ISO Fine Dust
1.0 g/m³ Feed Rate
25" H₂O (6.2 kPa)
Terminal Restriction
per ISO 5011

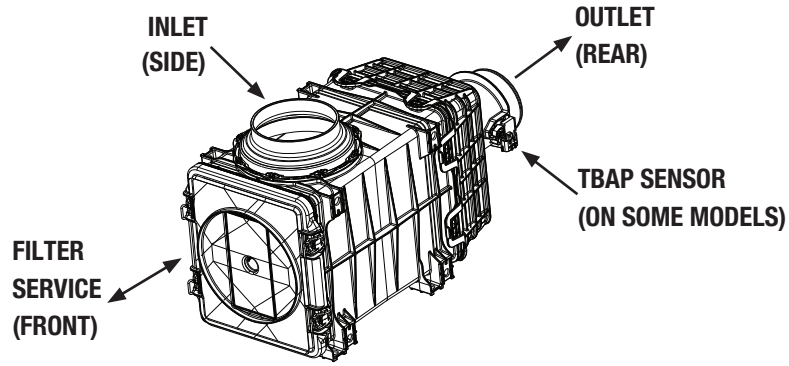

Specifications

Specifications	AH55644
Length, Overall	22.4" (570.8 mm)
Width, Overall	9.5" (241.3 mm)
Height, Overall	12.7" (322.8 mm)
Flow, MIN. AT 2" H ₂ O (0.5 kPa) Restriction	180 CFM (5.1 m ³ /min)
Flow, MAX. AT 12" H ₂ O (3.0 kPa) Restriction	480 CFM (13.6 m ³ /min)
Secondary Element	Yes
Housing Material	Glass-filled Polyamide
Pre-Cleaner	No
Inlet	90° to Outlet 5" (127 mm)
Outlet	Straight 4.0" (101.6 mm)
Filter Efficiency	≥ 99.90% per ISO 5011

Specifications Subject to change without notice.

Dust Holding Capacity per Flow Rate

Specification	Non Aspirated	
	CFM	m ³ /min
Maximum Flow for 10 g/CFM (357.1 g/m ³ /min)	230	6.5
Maximum Flow for 25 g/CFM (892.9 g/m ³ /min)	N/A*	N/A*

* Requires pre-cleaner (Optional)

Dimensions

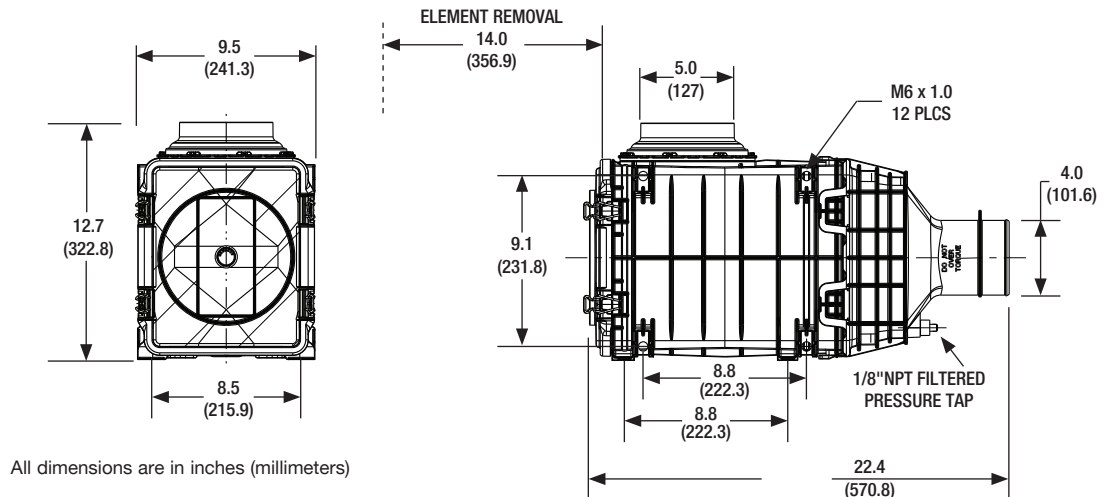

All dimensions are in inches (millimeters)

Ordering Information

Air Cleaners	
Part Number	Description
AH55644	Direct Flow -Side Inlet -With TBAP Sensor

Service Parts	
Part Number	Description
AF55021	Primary Element
AF55320	Secondary Element
SP1041	Front Service Cover
SP1060	M6 Mounting clips

Optional Accessories	
Part Number	Description
3316658S	4" Band Clamp
3316660S	5" Band Clamp
3316608S	4" Hump Hose
3316610S	5" Hump Hose
3316568S	4" 90° Elbow
3316570S	5" 90° Elbow
3316618S	5" to 4" Hump Hose Reducer
3946329S	Restriction Indicator

Additional sizes/shapes may be available.
Refer to the Cummins Filtration catalog or website.

Performance

System Restriction vs Flow Rate

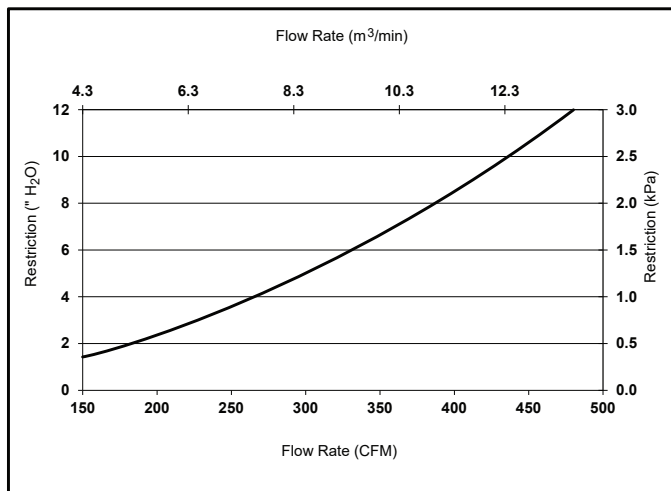

System Capacity vs Flow Rate

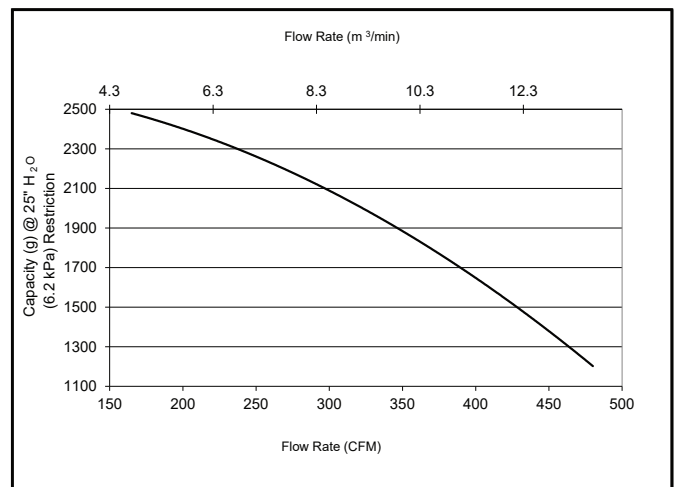

Restriction		Flow Rate		Typical Capacity at 25" H ₂ O (6.2 kPa) of Terminal Restriction
in H ₂ O	kPa	CFM	m³/min	Non Aspirated (g)
4.0	1.0	265	7.5	2225
6.0	1.5	330	9.3	1975
8.0	2.0	388	11.0	1700
10.0	2.5	435	12.3	1450
12.0	3.0	480	13.6	1200

ISO Fine Dust
1.0 g/m³ Feed Rate
25" H₂O (6.2 kPa)
Terminal Restriction
per ISO 5011

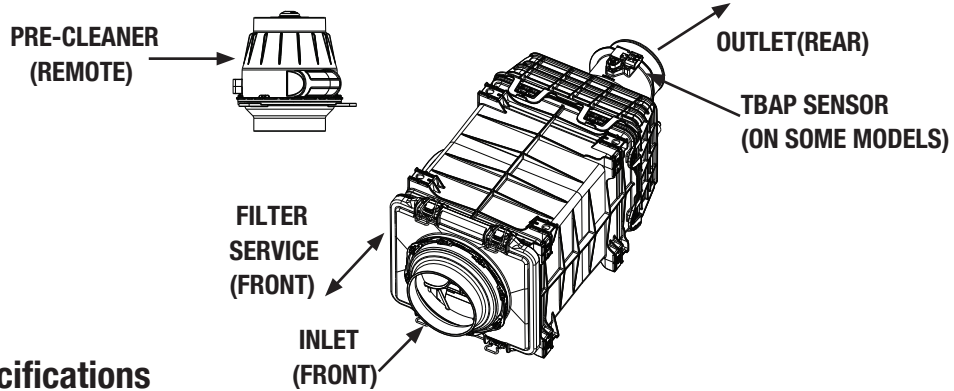

Specifications

Specifications	AK55696
Length, Overall	24.5" (622.8 mm)
Width, Overall	9.5" (241.3 mm)
Height, Overall	10.9" (277.4 mm)
Flow, MIN. AT 2" H ₂ O (0.5 kPa) Restriction	155 CFM (4.4 m ³ /min)
Flow, MAX. AT 12" H ₂ O (3.0 kPa) Restriction	378 CFM (10.7 m ³ /min)
Secondary Element	Yes
Housing Material	Glass-filled Polyamide
Pre-Cleaner	Remote
Inlet	Straight 5" (127 mm)
Outlet	Straight 4" (101.6 mm)
Filter Efficiency	≥ 99.90% per ISO 5011

Specifications Subject to change without notice.

Dust Holding Capacity per Flow Rate

Specification	Non Aspirated	
	CFM	m ³ /min
Maximum Flow for 10 g/CFM (357.1 g/m ³ /min)	378*	10.7*
Maximum Flow for 25 g/CFM (892.9 g/m ³ /min)	292	8.2

* Indicates maximum recommended flow rate.

Dimensions

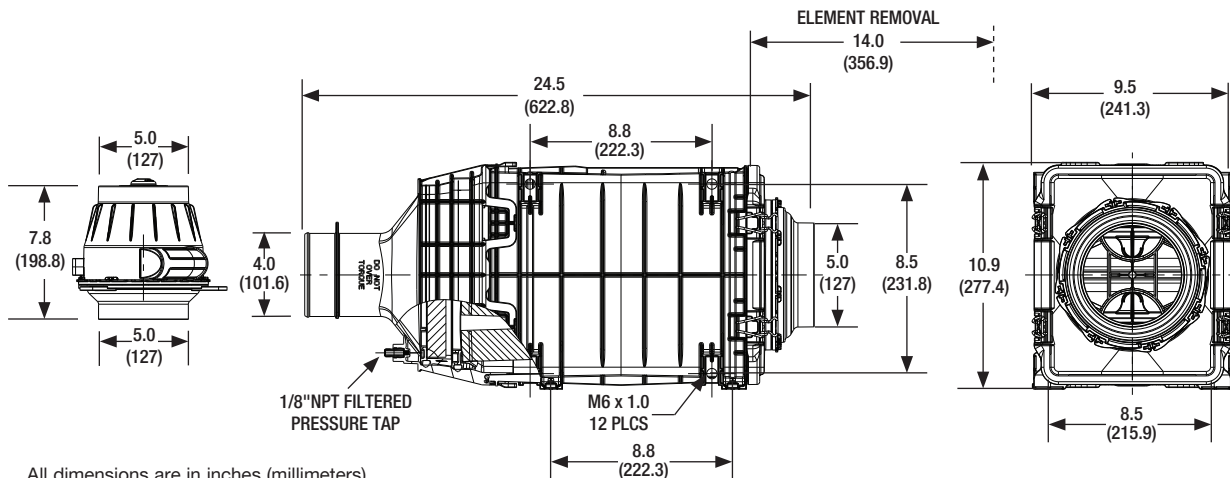

All dimensions are in inches (millimeters)

Ordering Information

Air Cleaners	
Part Number	Description
AK55696	Direct Flow -Front Inlet -Remote Pre-Cleaner -With TBAP Sensor

Service Parts	
Part Number	Description
AF55021	Primary Element
AF55320	Secondary Element
AP15914	Pre-Cleaner
AP15912	Pre-Cleaner remote adapter
SP1048	Dust Ejection Valve (DEV)
SP1060	M6 Mounting clips
SP1042	Front Service Cover

Optional Accessories	
Part Number	Description
3316658S	4" Band Clamp
3316660S	5" Band Clamp
3316608S	4" Hump Hose
3316610S	5" Hump Hose
3316568S	4" 90° Elbow
3316570S	5" 90° Elbow
3316618S	5" to 4" Hump Hose Reducer
3946329S	Restriction Indicator

Additional sizes/shapes may be available. Refer to the Cummins Filtration catalog or website.

Performance

System Restriction vs Flow Rate

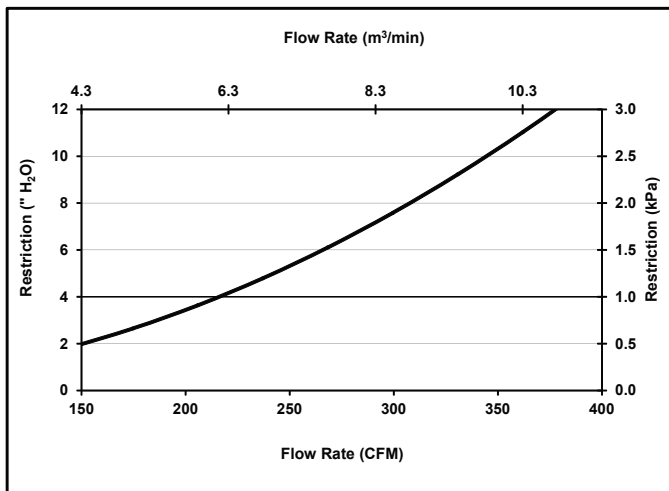

System Capacity vs Flow Rate

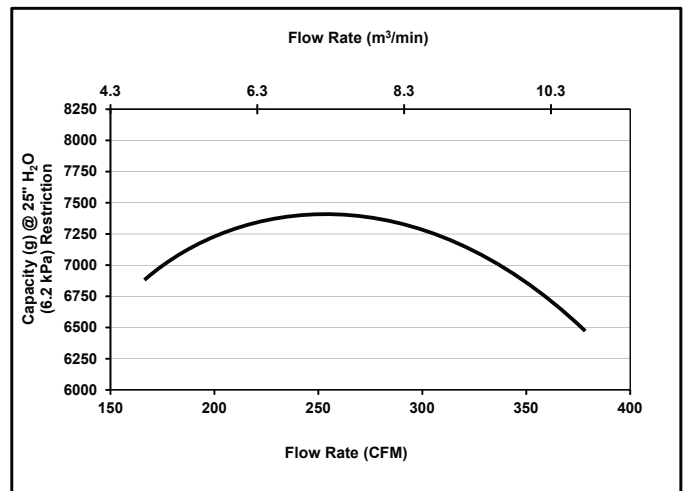

Restriction		Flow Rate		Typical Capacity at 25" H ₂ O (6.2 kPa) of Terminal Restriction
in H ₂ O	kPa	CFM	m³/min	Non Aspirated (g)
4.0	1.0	215	6.1	7300
6.0	1.5	265	7.5	7400
8.0	2.0	308	8.7	7250
10.0	2.5	345	9.8	6900
12.0	3.0	378	10.7	6500

ISO Coarse Dust
2.0 g/m³ Feed Rate
25" H₂O (6.2 kPa)
Terminal Restriction
per ISO 5011

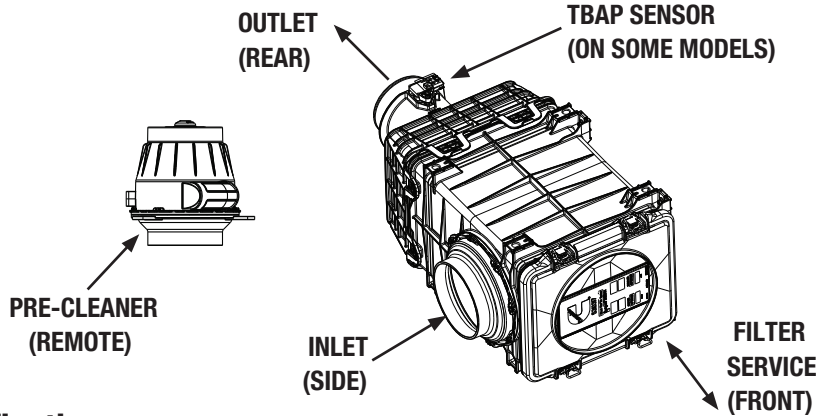

Specifications

Specifications	AK55697
Length, Overall	22.4" (570.8 mm)
Width, Overall	9.5" (241.3 mm)
Height, Overall	12.7" (322.8 mm)
Flow, MIN. AT 2" H ₂ O (0.5 kPa) Restriction	155 CFM (4.4 m ³ /min)
Flow, MAX. AT 12" H ₂ O (3.0 kPa) Restriction	378 CFM (10.7 m ³ /min)
Secondary Element	Yes
Housing Material	Glass-filled Polyamide
Pre-Cleaner	Remote
Inlet	90° to Outlet 5" (127 mm)
Outlet	Straight 4" (101.6 mm)
Filter Efficiency	≥ 99.90% per ISO 5011

Specifications Subject to change without notice.

Dust Holding Capacity per Flow Rate

Specification	Non Aspirated	
	CFM	m ³ /min
Maximum Flow for 10 g/CFM (357.1 g/m ³ /min)	378*	10.7*
Maximum Flow for 25 g/CFM (892.9 g/m ³ /min)	292	8.2

* Indicates maximum recommended flow rate.

Dimensions

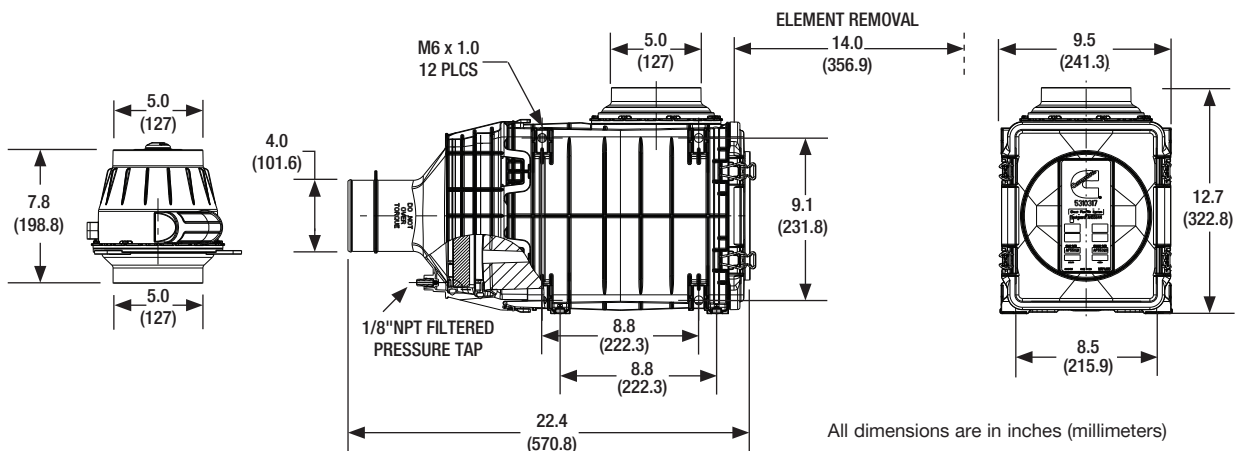

All dimensions are in inches (millimeters)

Ordering Information

Air Cleaners	
Part Number	Description
AK55697	Direct Flow -Side Inlet -Remote Pre-Cleaner -With TBAP Sensor

Service Parts	
Part Number	Description
AF55021	Primary Element
AF55320	Secondary Element
AP15914	Pre-Cleaner
AP15912	Pre-Cleaner Remote Adapter
SP1048	Dust Ejection Valve (DEV)
SP1060	M6 Mounting clips
SP1041	Front Service Cover

Optional Accessories	
Part Number	Description
3316658S	4" Band Clamp
3316660S	5" Band Clamp
3316608S	4" Hump Hose
3316610S	5" Hump Hose
3316568S	4" 90° Elbow
3316570S	5" 90° Elbow
3316618S	5" to 4" Hump Hose Reducer
3946329S	Restriction Indicator

Additional sizes/shapes may be available. Refer to the Cummins Filtration catalog or website.

Performance

System Restriction vs Flow Rate

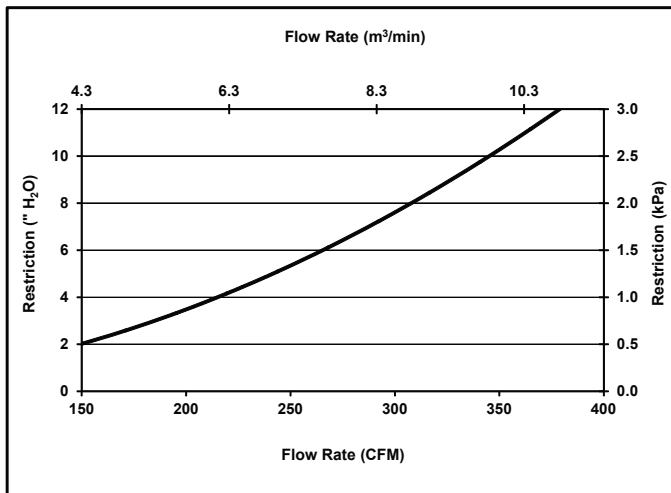

System Capacity vs Flow Rate

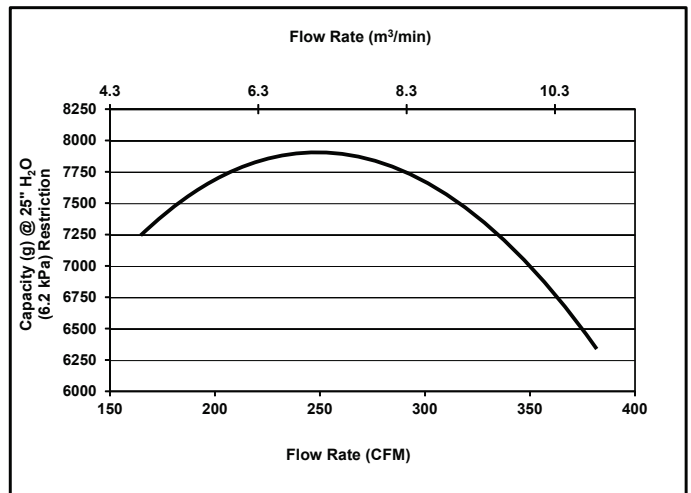

*Data reflects the pre-cleaner as integrated.

Restriction		Flow Rate		Typical Capacity at 25" H ₂ O (6.2 kPa) of Terminal Restriction
in H ₂ O	kPa	CFM	m³/min	Non Aspirated (g)
4.0	1.0	215	6.1	7800
6.0	1.5	265	7.5	7900
8.0	2.0	308	8.7	7600
10.0	2.5	345	9.8	7100
12.0	3.0	378	10.7	6400

ISO Coarse Dust
2.0 g/m³ Feed Rate
25" H₂O (6.2 kPa)
Terminal Restriction
per ISO 5011

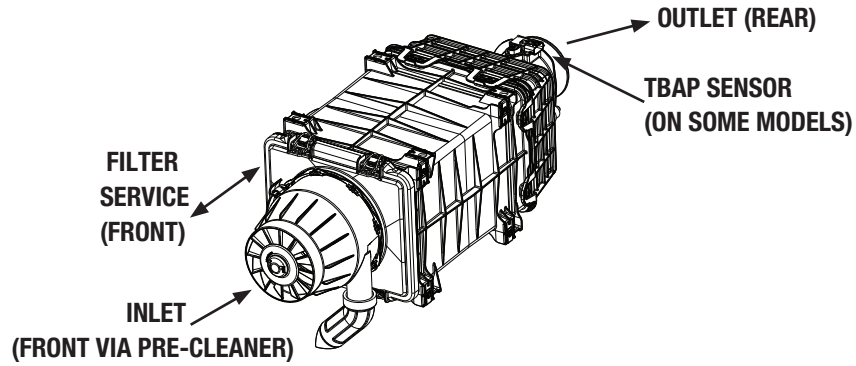

Specifications

Specifications	AK55698
Length, Overall	28.2" (717.3 mm)
Width, Overall	10.9" (277.4 mm)
Height, Overall	9.5" (241.3 mm)
Flow, MIN. AT 2" H ₂ O (0.5 kPa) Restriction	155 CFM (4.4 m ³ /min)
Flow, MAX. AT 12" H ₂ O (3.0 kPa) Restriction	378 CFM (10.7 m ³ /min)
Secondary Element	Yes
Housing Material	Glass-filled Polyamide
Pre-Cleaner	Integrated
Inlet	Straight - via pre-cleaner, 5" (127 mm)
Outlet	Straight 4.0" (101.6 mm)
Filter Efficiency	≥ 99.90% per ISO 5011

Specifications Subject to change without notice.

Dust Holding Capacity per Flow Rate

Specification	Non Aspirated	
	CFM	m ³ /min
Maximum Flow for 10 g/CFM (357.1 g/m ³ /min)	378*	10.7*
Maximum Flow for 25 g/CFM (892.9 g/m ³ /min)	292	8.2

* Indicates maximum recommended flow rate.

Dimensions

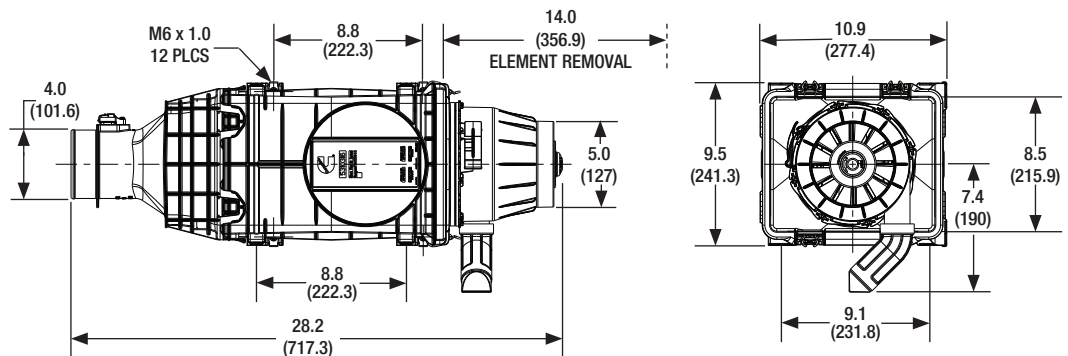

All dimensions are in inches (millimeters)

Ordering Information

Air Cleaners	
Part Number	Description
AK55698	Direct Flow -Front Inlet -Integrated Pre-Cleaner -With TBAP Sensor

Service Parts	
Part Number	Description
AF55021	Primary Element
AF55320	Secondary Element
SP1048	Dust Ejection Valve (DEV)
SP1060	M6 Mounting clips
SP1042	Front Service Cover
AP15914	Pre-Cleaner

Optional Accessories	
Part Number	Description
3316658S	4" Band Clamp
3316660S	5" Band Clamp
3316608S	4" Hump Hose
3316610S	5" Hump Hose
3316568S	4" 90° Elbow
3316570S	5" 90° Elbow
3316618S	5" to 4" Hump Hose Reducer
3946329S	Restriction Indicator

Additional sizes/shapes may be available.
Refer to the Cummins Filtration catalog or website.

Performance

System Restriction vs Flow Rate

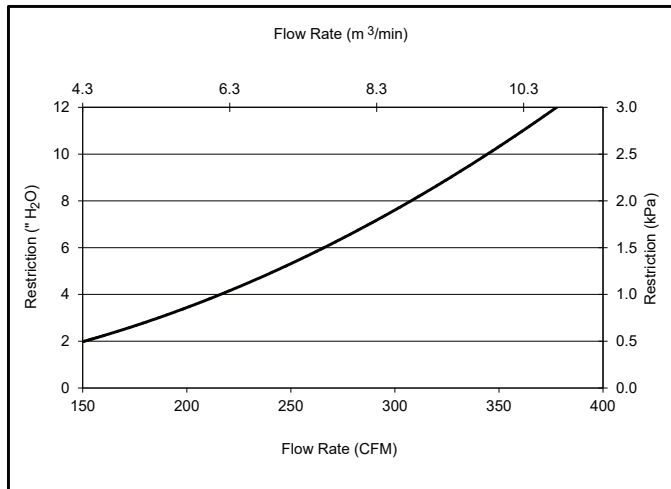

System Capacity vs Flow Rate

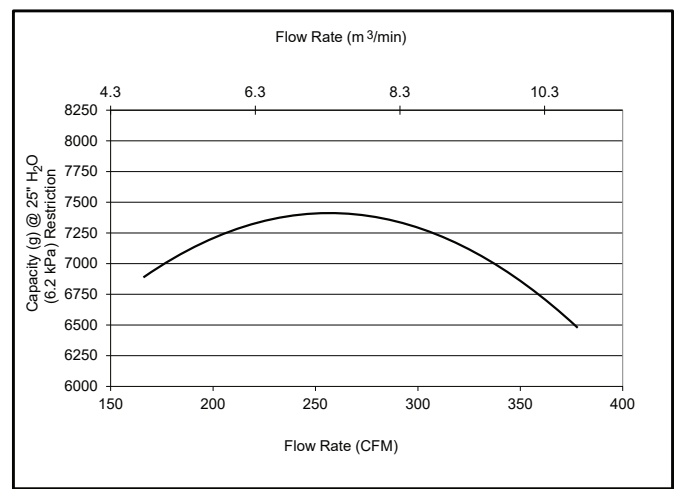

Restriction		Flow Rate		Typical Capacity at 25" H ₂ O (6.2 kPa) of Terminal Restriction Non Aspirated (g)
in H ₂ O	kPa	CFM	m³/min	
4.0	1.0	215	6.1	7300
6.0	1.5	265	7.5	7400
8.0	2.0	308	8.7	7250
10.0	2.5	345	9.8	6900
12.0	3.0	378	10.7	6500

ISO Coarse Dust
2.0 g/m³ Feed Rate
25" H₂O (6.2 kPa)
Terminal Restriction
per ISO 5011

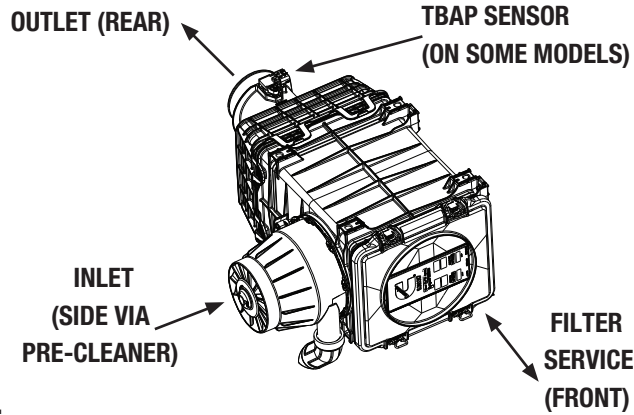

Specifications

Specifications	AK55699
Length, Overall	22.5" (570.8 mm)
Width, Overall	16.9" (429.7 mm)
Height, Overall	9.5" (241.3 mm)
Flow, MIN. AT 2" H ₂ O (0.5 kPa) Restriction	155 CFM (4.4 m ³ /min)
Flow, MAX. AT 12" H ₂ O (3.0 kPa) Restriction	378 CFM (10.7 m ³ /min)
Secondary Element	Yes
Housing Material	Glass-filled Polyamide
Pre-Cleaner	Integrated
Inlet	90° to Outlet - via pre-cleaner, 5" (127 mm)
Outlet	Straight 4.0" (101.6 mm)
Filter Efficiency	≥ 99.90% per ISO 5011

Specifications Subject to change without notice.

Dust Holding Capacity per Flow Rate

Specification	Non Aspirated	
	CFM	m ³ /min
Maximum Flow for 10 g/CFM (357.1 g/m ³ /min)	378*	10.7*
Maximum Flow for 25 g/CFM (892.9 g/m ³ /min)	307	8.7

* Indicates maximum recommended flow rate.

Dimensions

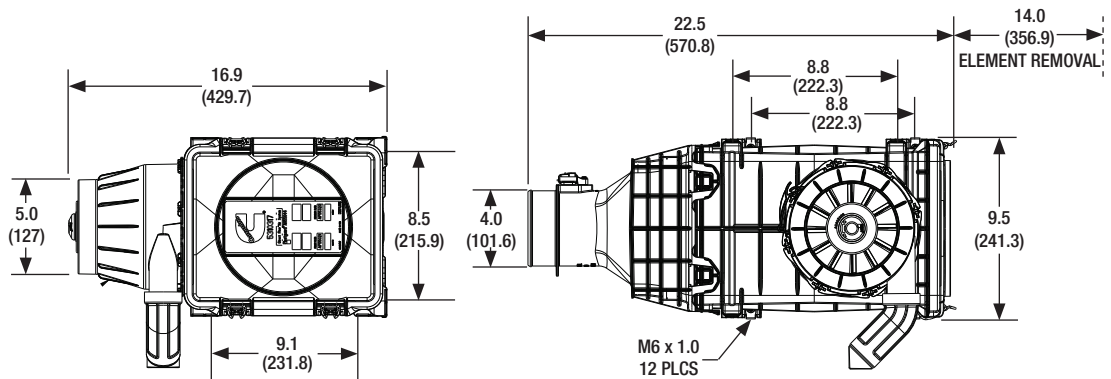

All dimensions are in inches (millimeters)

Ordering Information

Air Cleaners	
Part Number	Description
AK55699	Direct Flow -Side Inlet -Integrated Pre-Cleaner -With TBAP Sensor

Service Parts	
Part Number	Description
AF55021	Primary Element
AF55320	Secondary Element
SP1048	Dust Ejection Valve (DEV)
SP1060	M6 Mounting clips
SP1041	Front Service Cover
AP15914	Pre-Cleaner

Optional Accessories	
Part Number	Description
3316658S	4" Band Clamp
3316660S	5" Band Clamp
3316608S	4" Hump Hose
3316610S	5" Hump Hose
3316568S	4" 90° Elbow
3316570S	5" 90° Elbow
3316618S	5" to 4" Hump Hose Reducer
3946329S	Restriction Indicator

Additional sizes/shapes may be available.
Refer to the Cummins Filtration catalog or website.

Performance

System Restriction vs Flow Rate

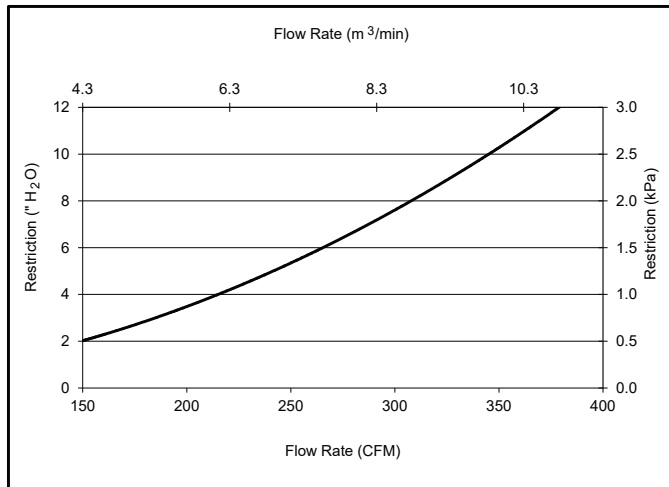

System Capacity vs Flow Rate

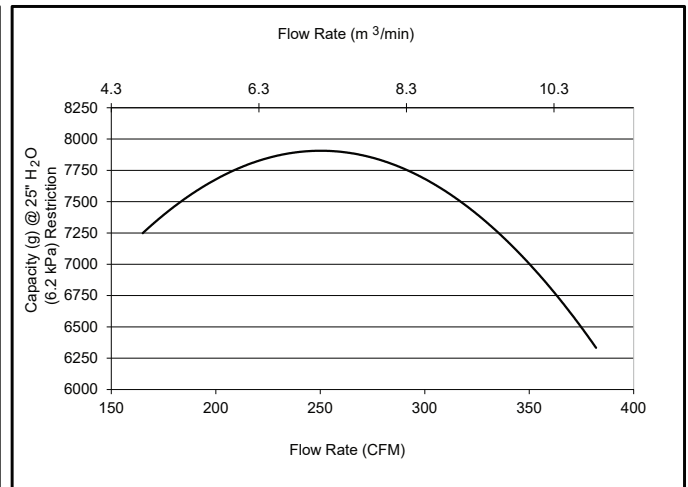

Restriction		Flow Rate		Typical Capacity at 25" H ₂ O (6.2 kPa) of Terminal Restriction
in H ₂ O	kPa	CFM	m³/min	Non Aspirated (g)
4.0	1.0	215	6.1	7800
6.0	1.5	265	7.5	7900
8.0	2.0	308	8.7	7600
10.0	2.5	345	9.8	7100
12.0	3.0	378	10.7	6400

ISO Coarse Dust
2.0 g/m³ Feed Rate
25" H₂O (6.2 kPa)
Terminal Restriction
per ISO 5011

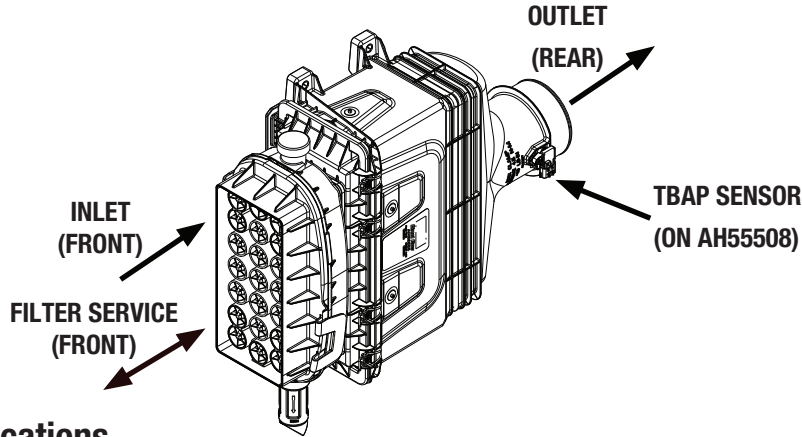

Specifications

Specification	AH55508 • AH55555
Length, Overall	25.3" (643 mm)
Width, Overall	9.1" (230 mm)
Height, Overall	22.3" (566 mm)
Flow, Min. at 2" H ₂ O (0.5 kPa) Restriction	200 CFM (5.66 m ³ /min)
Flow, Max. at 12" H ₂ O (3.0 kPa) Restriction	556 CFM (15.74 m ³ /min)
Secondary Element	Yes
Housing Material	Glass-Filled Polyamide
Pre-Cleaner	Integral, Spinner-tube Type
Inlet	Via Pre-Cleaner
Outlet	Straight, 5.0" (127 mm)
Filter Efficiency	≥ 99.90% per ISO 5011

Specifications subject to change without notice.

Dust Holding Capacity per Flow Rate

Specification	Aspirated		Non Aspirated	
	CFM	m ³ /min	CFM	m ³ /min
Maximum Flow for 10 g/CFM (3500 g/m ³ /min)	556*	15.7*	556*	15.7*
Maximum Flow for 25 g/CFM (8750 g/m ³ /min)	490	13.9	340	9.6

*Indicates maximum recommended flow rate

Dimensions

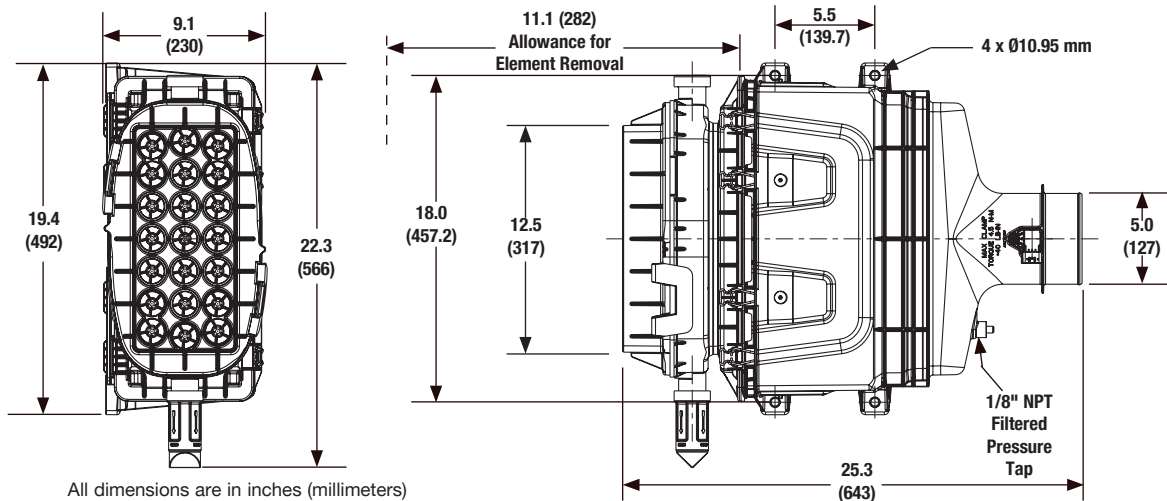

All dimensions are in inches (millimeters)

Ordering Information

Air Cleaners	
Part Number	Description
AH55508	Direct Flow - Integrated Pre-Cleaner - Front Inlet - With TBAP Sensor
AH55555	Direct Flow - Integrated Pre-Cleaner - Front Inlet - Without TBAP Sensor

Service Parts	
Part Number	Description
AF55005	Primary Element
AF55308	Secondary Element
SP1048	Dust Ejection Valve (DEV)
SP1004	Service Kit: DEV Tube, DEV Cap, -Clips (4)
SP1399	Service Cover with Latches

Optional Accessories	
Part Number	Description
3316658S	4" Band Clamp
3316660S	5" Band Clamp
3316608S	4" Hump Hose
3316610S	5" Hump Hose
3316568S	4" 90° Elbow
3316570S	5" 90° Elbow
3316618S	5" to 4" Hump Hose Reducer
3946329S	Restriction Indicator

Additional sizes/shapes may be available.
Refer to the Cummins Filtration catalog or website.

Performance

System Restriction vs Flow Rate

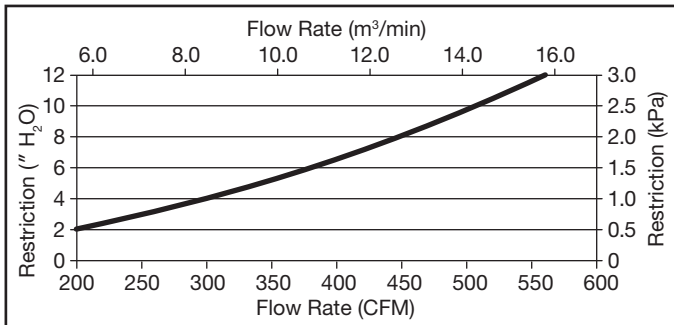

System Capacity vs Flow Rate

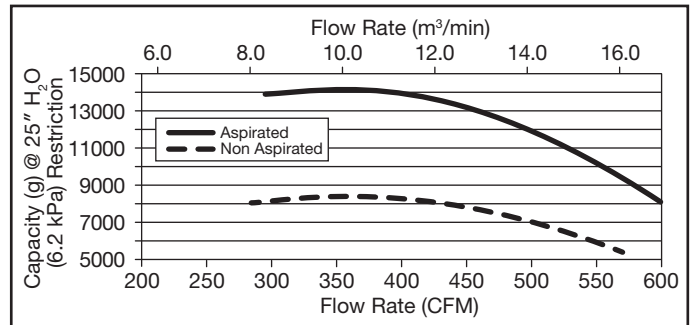

Restriction		Flow Rate		Typical Capacity at 25" H ₂ O (6.2 kPa) of Terminal Restriction	
in H ₂ O	kPa	CFM	m³/min	Aspirated (g)	Non Aspirated (g)
4	1.0	303	8.6	13872	8221
6	1.5	381	10.8	14088	8351
8	2.0	446	12.6	13392	7863
10	2.5	504	14.3	12118	6982
12	3.0	556	15.7	10433	5823

ISO Coarse Dust
2.0 g/m³ Feed Rate
25" H₂O (6.2 kPa)
Terminal Restriction
per ISO 5011

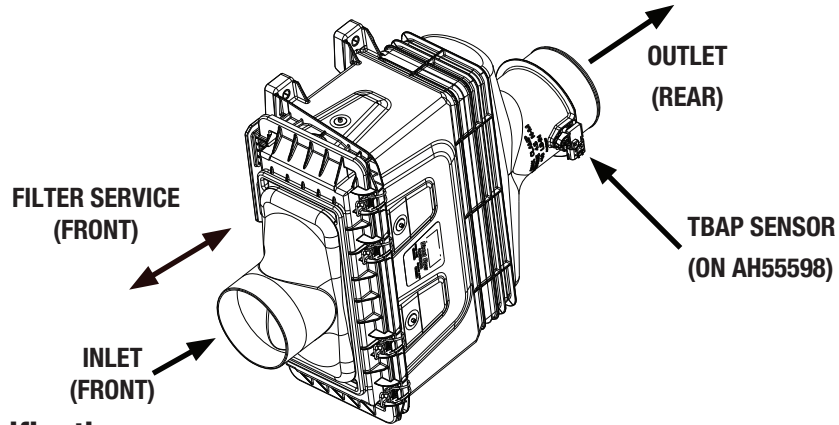

Specifications

Specification	AH55598 • AH55602
Length, Overall	24.9" (633 mm)
Width, Overall	8.9" (225.5 mm)
Height, Overall	19.4" (492 mm)
Flow, Min. at 2" H ₂ O (0.5 kPa) Restriction	220 CFM (6.2 m ³ /min)
Flow, Max. at 12" H ₂ O (3.0 kPa) Restriction	645 CFM (18.2 m ³ /min)
Secondary Element	Yes
Housing Material	Glass-Filled Polyamide
Pre-Cleaner	No
Inlet	Straight, 5.0" (127 mm)
Outlet	Straight, 5.0" (127 mm)
Filter Efficiency	≥ 99.90% per ISO 5011

Specifications subject to change without notice.

Dust Holding Capacity per Flow Rate

Specification	Non Aspirated	
	CFM	m ³ /min
Maximum Flow for 10 g/CFM (3500 g/m ³ /min)	210	6.0
Maximum Flow for 25 g/CFM (8750 g/m ³ /min)	N/A*	N/A*

*Requires precleaner (optional)

Dimensions

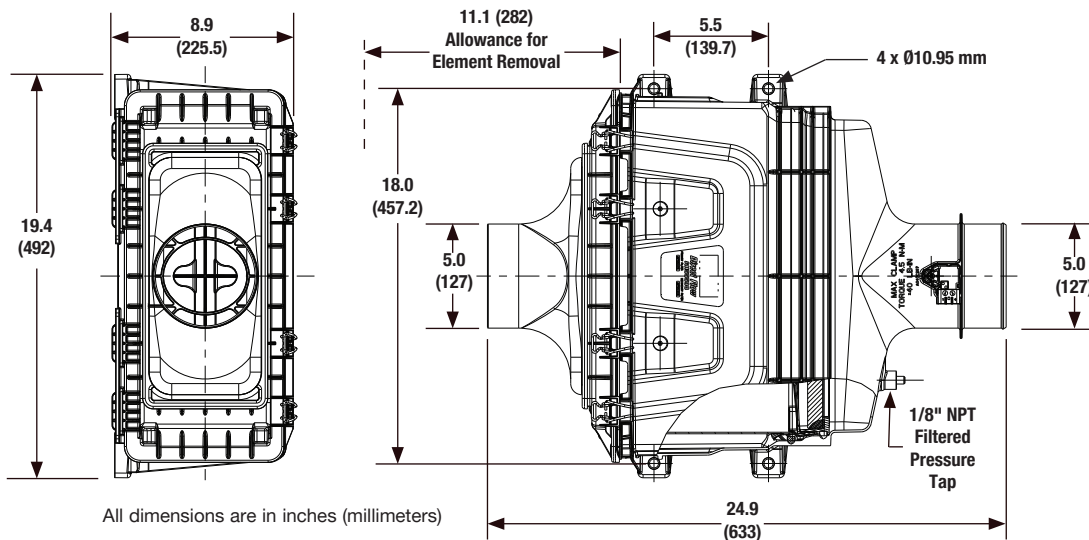

Ordering Information

Air Cleaners	
Part Number	Description
AH55598	Direct Flow - Front Inlet - With TBAP Sensor
AH55602	Direct Flow - Front Inlet - Without TBAP Sensor

Service Parts	
Part Number	Description
AF55005	Primary Element
AF55308	Secondary Element
SP1004	Service Kit: DEV Tube, DEV Cap, -Clips (4)
SP1398	Service Cover with Latches

Optional Accessories	
Part Number	Description
3316658S	4" Band Clamp
3316660S	5" Band Clamp
3316608S	4" Hump Hose
3316610S	5" Hump Hose
3316568S	4" 90° Elbow
3316570S	5" 90° Elbow
3316618S	5" to 4" Hump Hose Reducer
3946329S	Restriction Indicator

Additional sizes/shapes may be available.
Refer to the Cummins Filtration catalog or website.

Performance

System Restriction vs Flow Rate

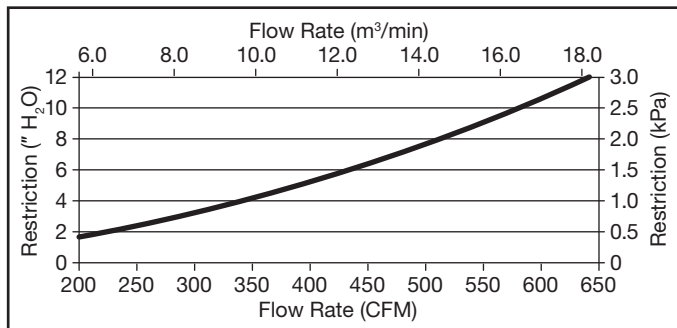

System Capacity vs Flow Rate

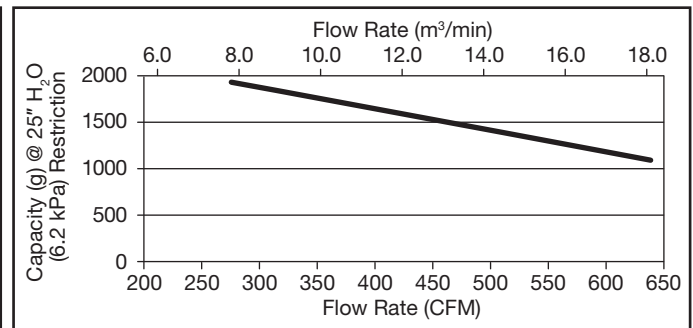

Restriction		Flow Rate		Typical Capacity at 25" H ₂ O (6.2 kPa) of Terminal Restriction
in H ₂ O	kPa	CFM	m³/min	Non Aspirated (g)
4	1.0	325	9.2	1823
6	1.5	420	11.9	1602
8	2.0	515	14.6	1374
10	2.5	580	16.4	1214
12	3.0	645	18.3	1050

ISO Fine Dust
1.0 g/m³ Feed Rate
25" H₂O (6.2 kPa)
Terminal Restriction
per ISO 5011

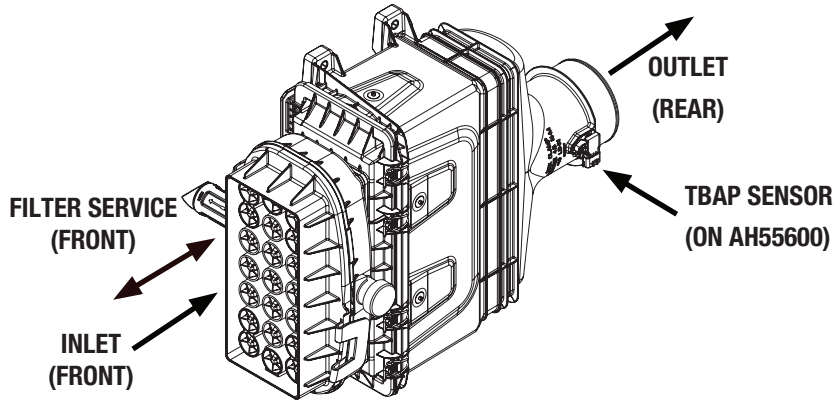

Specifications

Specification	AH55600 • AH55604
Length, Overall	25.3" (643 mm)
Width, Overall	14.8" (377 mm)
Height, Overall	19.4" (492 mm)
Flow, Min. at 2" H ₂ O (0.5 kPa) Restriction	200 CFM (5.7 m ³ /min)
Flow, Max. at 12" H ₂ O (3.0 kPa) Restriction	560 CFM (15.8 m ³ /min)
Secondary Element	Yes
Housing Material	Glass-Filled Polyamide
Pre-Cleaner	Integral, Spinner-tube Type
Inlet	Via Pre-Cleaner
Outlet	Straight, 5.0" (127 mm)
Filter Efficiency	≥ 99.90% per ISO 5011

Specifications subject to change without notice.

Dust Holding Capacity per Flow Rate

Specification	Aspirated		Non Aspirated	
	CFM	m ³ /min	CFM	m ³ /min
Maximum Flow for 10 g/CFM (3500 g/m ³ /min)	560*	15.9*	560*	15.9*
Maximum Flow for 25 g/CFM (8750 g/m ³ /min)	510	14.4	260	7.4

*Indicates maximum recommended flow rate

Dimensions

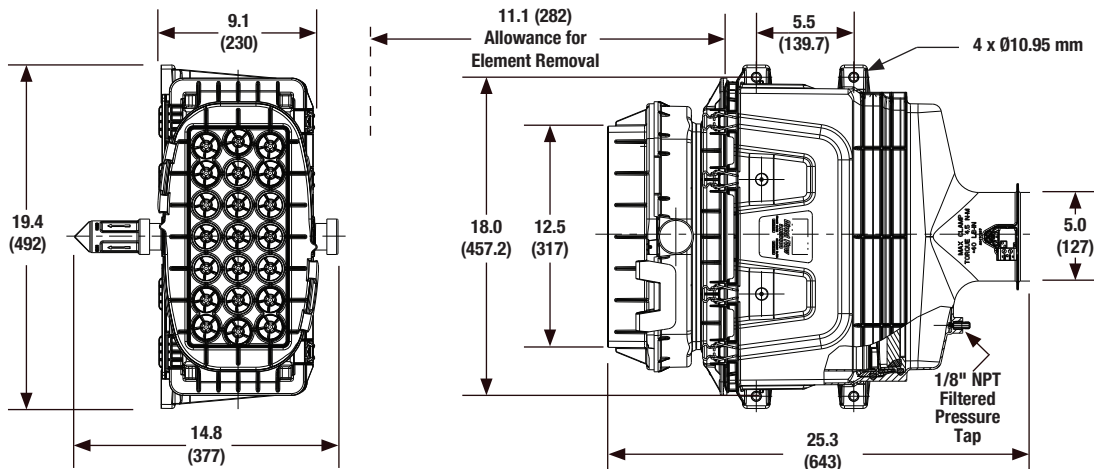

All dimensions are in inches (millimeters)

Ordering Information

Air Cleaners	
Part Number	Description
AH55600	Direct Flow - Integrated Pre-Cleaner - Front Inlet - With TBAP Sensor
AH55604	Direct Flow - Integrated Pre-Cleaner - Front Inlet - Without TBAP Sensor

Service Parts	
Part Number	Description
AF55005	Primary Element
AF55308	Secondary Element
SP1048	Dust Ejection Valve (DEV)
SP1004	Service Kit: DEV Tube, DEV Cap, -Clips (4)
SP1397	Service Cover with Latches

Optional Accessories	
Part Number	Description
3316658S	4" Band Clamp
3316660S	5" Band Clamp
3316608S	4" Hump Hose
3316610S	5" Hump Hose
3316568S	4" 90° Elbow
3316570S	5" 90° Elbow
3316618S	5" to 4" Hump Hose Reducer
3946329S	Restriction Indicator

Additional sizes/shapes may be available. Refer to the Cummins Filtration catalog or website.

Performance

System Restriction vs Flow Rate

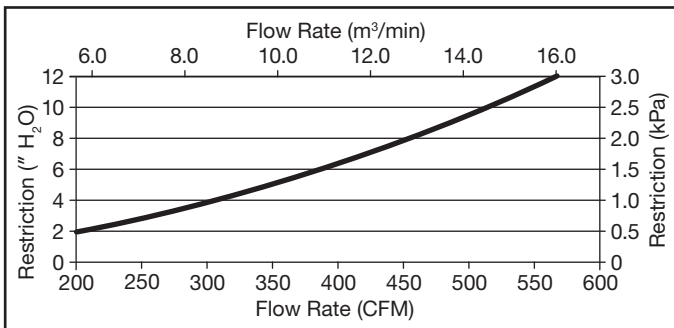

System Capacity vs Flow Rate

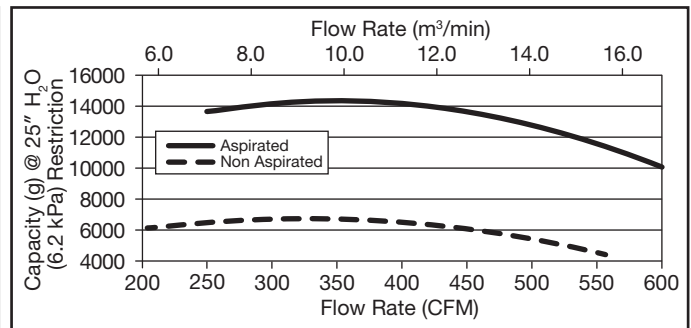

Restriction		Flow Rate		Typical Capacity at 25" H ₂ O (6.2 kPa) of Terminal Restriction	
in H ₂ O	kPa	CFM	m³/min	Aspirated (g)	Non Aspirated (g)
4	1.0	305	8.6	14179	6731
6	1.5	380	10.8	14312	6614
8	2.0	455	12.9	13705	6012
10	2.5	508	14.4	12747	5302
12	3.0	560	15.9	11305	4355

ISO Coarse Dust
2.0 g/m³ Feed Rate
25" H₂O (6.2 kPa)
Terminal Restriction
per ISO 5011

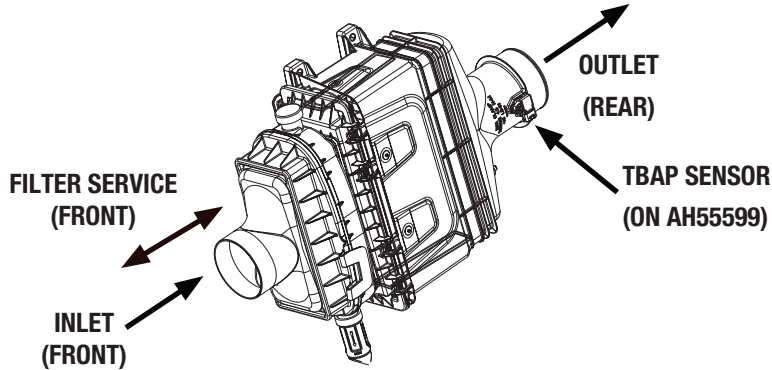

Specifications

Specification	AH55599 • AH55603
Length, Overall	29.9" (759 mm)
Width, Overall	9.1" (230 mm)
Height, Overall	22.3" (566 mm)
Flow, Min. at 2" H ₂ O (0.5 kPa) Restriction	180 CFM (5.1 m ³ /min)
Flow, Max. at 12" H ₂ O (3.0 kPa) Restriction	512 CFM (14.5 m ³ /min)
Secondary Element	Yes
Housing Material	Glass-Filled Polyamide
Pre-Cleaner	Integral, Spinner-tube Type
Inlet	Straight, 5.0" (127 mm)
Outlet	Straight, 5.0" (127 mm)
Filter Efficiency	≥ 99.90% per ISO 5011

Specifications subject to change without notice.

Dust Holding Capacity per Flow Rate

Specification	Aspirated		Non Aspirated	
	CFM	m ³ /min	CFM	m ³ /min
Maximum Flow for 10 g/CFM (3500 g/m ³ /min)	512*	14.5*	480	13.6
Maximum Flow for 25 g/CFM (8750 g/m ³ /min)	475	13.5	250	7.1

*Indicates maximum recommended flow rate

Dimensions

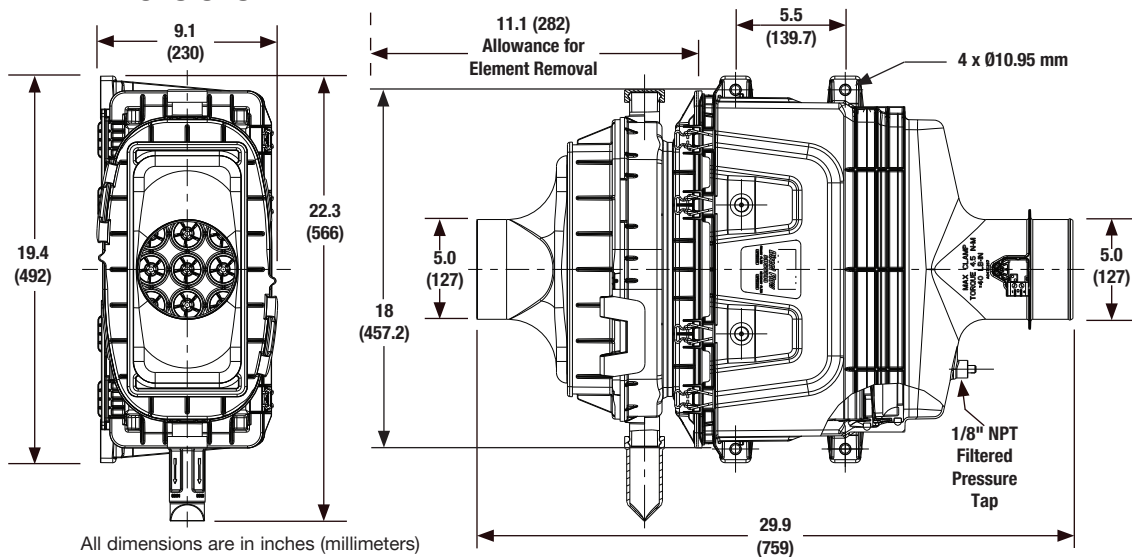

Ordering Information

Air Cleaners	
Part Number	Description
AH55599	Direct Flow - Integrated Pre-Cleaner - Front Inlet - With TBAP Sensor
AH55603	Direct Flow - Integrated Pre-Cleaner - Front Inlet - Without TBAP Sensor

Service Parts	
Part Number	Description
AF55005	Primary Element
AF55308	Secondary Element
SP1048	Dust Ejection Valve (DEV)
SP1004	Service Kit: DEV Tube, DEV Cap, -Clips (4)
SP1399	Service Cover with Latches

Optional Accessories	
Part Number	Description
3316658S	4" Band Clamp
3316660S	5" Band Clamp
3316608S	4" Hump Hose
3316610S	5" Hump Hose
3316568S	4" 90° Elbow
3316570S	5" 90° Elbow
3316618S	5" to 4" Hump Hose Reducer
3946329S	Restriction Indicator

Additional sizes/shapes may be available.
Refer to the Cummins Filtration catalog or website.

Performance

System Restriction vs Flow Rate

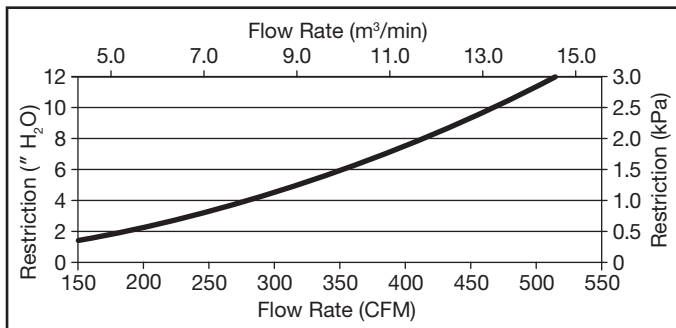

System Capacity vs Flow Rate

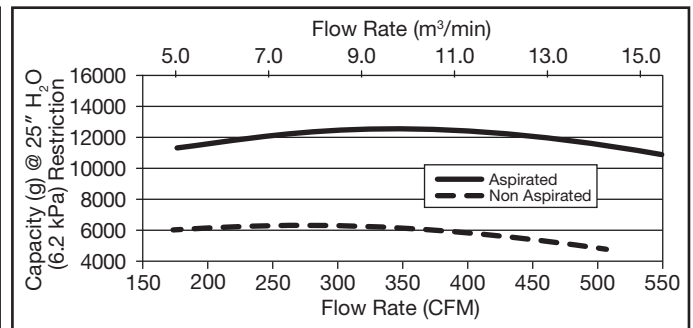

Restriction		Flow Rate		Typical Capacity at 25" H ₂ O (6.2 kPa) of Terminal Restriction	
in H ₂ O	kPa	CFM	m³/min	Aspirated (g)	Non Aspirated (g)
4	1.0	277	7.8	12262	6255
6	1.5	343	9.7	12503	6117
8	2.0	409	11.6	12385	5740
10	2.5	465	13.2	12004	5233
12	3.0	512	14.5	11484	4674

ISO Coarse Dust
2.0 g/m³ Feed Rate
25" H₂O (6.2 kPa)
Terminal Restriction
per ISO 5011

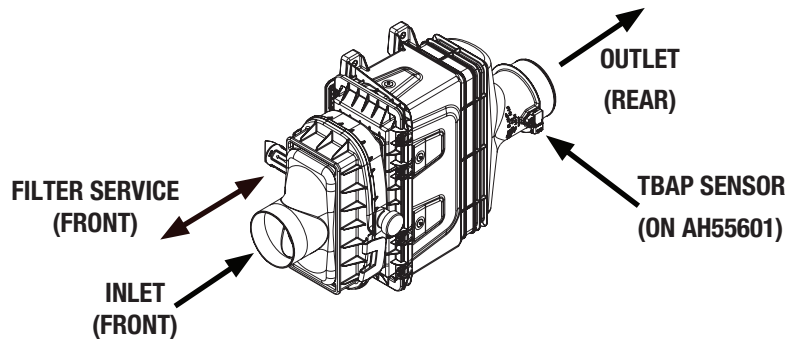

Specifications

Specification	AH55601 • AH55605
Length, Overall	29.9" (759 mm)
Width, Overall	14.8" (377 mm)
Height, Overall	19.4" (493 mm)
Flow, Min. at 2" H ₂ O (0.5 kPa) Restriction	180 CFM (5.1 m ³ /min)
Flow, Max. at 12" H ₂ O (3.0 kPa) Restriction	520 CFM (14.7 m ³ /min)
Secondary Element	Yes
Housing Material	Glass-Filled Polyamide
Pre-Cleaner	Integral, Spinner-tube Type
Inlet	Straight, 5" (127 mm)
Outlet	Straight, 5" (127 mm)
Filter Efficiency	≥ 99.90% per ISO 5011

Specifications subject to change without notice.

Dust Holding Capacity per Flow Rate

Specification	Aspirated		Non Aspirated	
	CFM	m ³ /min	CFM	m ³ /min
Maximum Flow for 10 g/CFM (3500 g/m ³ /min)	520*	14.7*	420	11.9
Maximum Flow for 25 g/CFM (8750 g/m ³ /min)	430	12.2	200	5.7

*Indicates maximum recommended flow rate

Dimensions

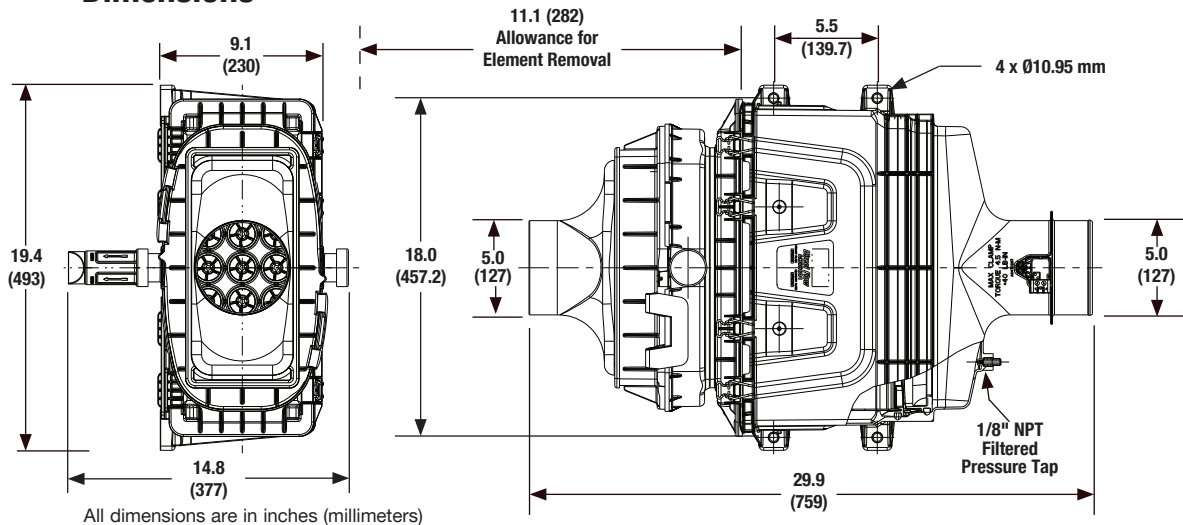

All dimensions are in inches (millimeters)

Ordering Information

Air Cleaners	
Part Number	Description
AH55601	Direct Flow - Integrated Pre-Cleaner - Front Inlet - With TBAP Sensor
AH55605	Direct Flow - Integrated Pre-Cleaner - Front Inlet - Without TBAP Sensor

Service Parts	
Part Number	Description
AF55005	Primary Element
AF55308	Secondary Element
SP1048	Dust Ejection Valve (DEV)
SP1004	Service Kit: DEV Tube, DEV Cap, -Clips (4)
SP1397	Service Cover with Latches

Optional Accessories	
Part Number	Description
3316658S	4" Band Clamp
3316660S	5" Band Clamp
3316608S	4" Hump Hose
3316610S	5" Hump Hose
3316568S	4" 90° Elbow
3316570S	5" 90° Elbow
3316618S	5" to 4" Hump Hose Reducer
3946329S	Restriction Indicator

Additional sizes/shapes may be available.
Refer to the Cummins Filtration catalog or website.

Performance

System Restriction vs Flow Rate

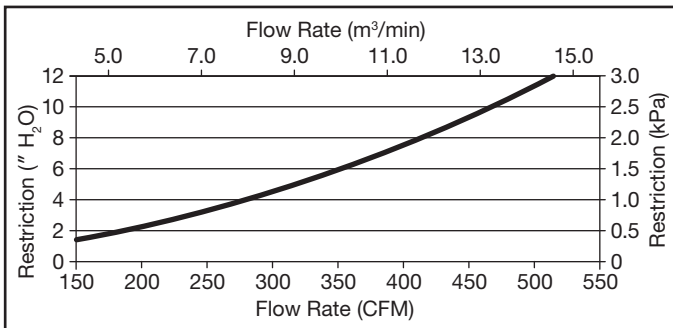

System Capacity vs Flow Rate

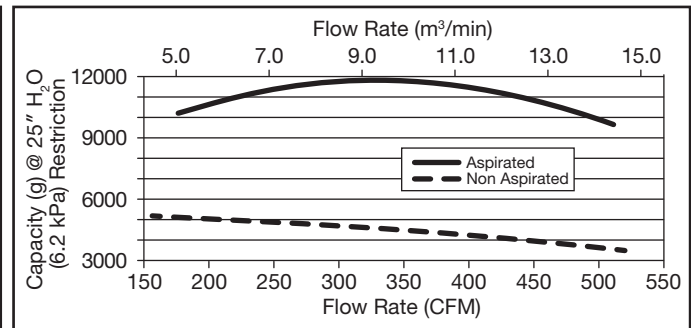

Restriction		Flow Rate		Typical Capacity at 25" H ₂ O (6.2 kPa) of Terminal Restriction	
in H ₂ O	kPa	CFM	m³/min	Aspirated (g)	Non Aspirated (g)
4	1.0	285	8.1	11571	4748
6	1.5	350	9.9	11749	4461
8	2.0	415	11.8	11366	4121
10	2.5	468	13.2	10687	3808
12	3.0	520	14.7	9680	3462

ISO Coarse Dust
2.0 g/m³ Feed Rate
25" H₂O (6.2 kPa)
Terminal Restriction
per ISO 5011

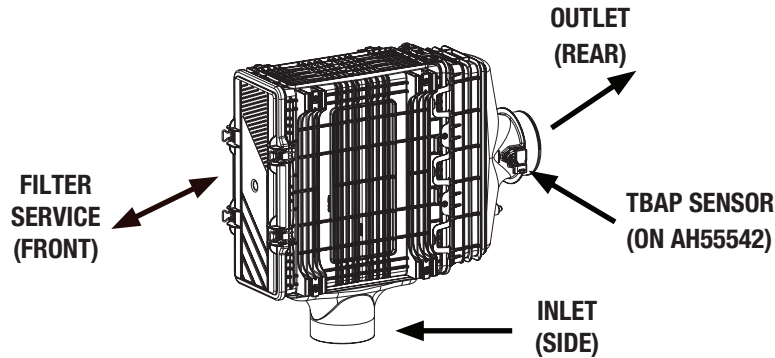

Specifications

Specification	AH55542 • AH55559
Length, Overall	24.8" (632 mm)
Width, Overall	8.9" (228 mm)
Height, Overall	22.0" (561 mm)
Flow, Min. at 2" H ₂ O (0.5 kPa) Restriction	220 CFM (6.23 m ³ /min)
Flow, Max. at 12" H ₂ O (3.0 kPa) Restriction	606 CFM (17.1 m ³ /min)
Secondary Element	Yes
Housing Material	Glass-Filled Polyamide
Pre-Cleaner	No
Inlet	Straight, 5.0" (127 mm)
Outlet	Straight, 5.0" (127 mm)
Filter Efficiency	≥ 99.90% per ISO 5011

Specifications subject to change without notice.

Dust Holding Capacity per Flow Rate

Specification	Non Aspirated	
	CFM	m ³ /min
Maximum Flow for 10 g/CFM (3500 g/m ³ /min)	280	7.9
Maximum Flow for 25 g/CFM (8750 g/m ³ /min)	N/A*	N/A*

*Requires precleaner (optional)

Dimensions

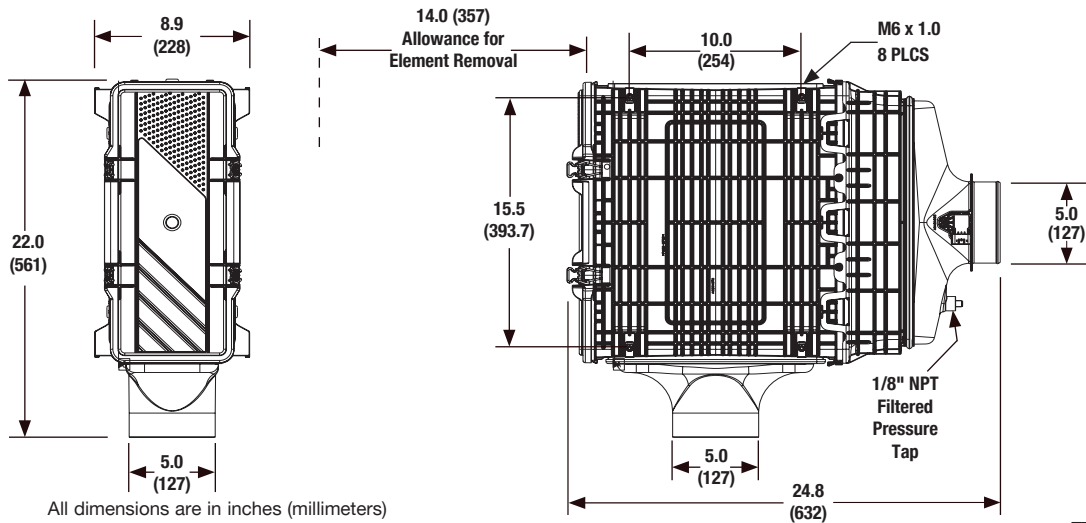

All dimensions are in inches (millimeters)

Ordering Information

Air Cleaners	
Part Number	Description
AH55542	Direct Flow - Side Inlet - With TBAP Sensor
AH55559	Direct Flow - Side Inlet - Without TBAP Sensor

Service Parts	
Part Number	Description
AF55014	Primary Element
AF55308	Secondary Element
SP1004	Service Kit: DEV Tube, DEV Cap, J-Clips (4)
SP1400	Service Cover with O-Ring

Optional Accessories	
Part Number	Description
3316658S	4" Band Clamp
3316660S	5" Band Clamp
3316608S	4" Hump hose
3316610S	5" Hump Hose
3316568S	4" 90° Elbow
3316570S	5" 90° Elbow
3316618S	5" to 4" Hump Hose Reducer
3946329S	Restriction Indicator

Additional sizes/shapes may be available. Refer to the Cummins Filtration catalog or website.

Performance

System Restriction vs Flow Rate

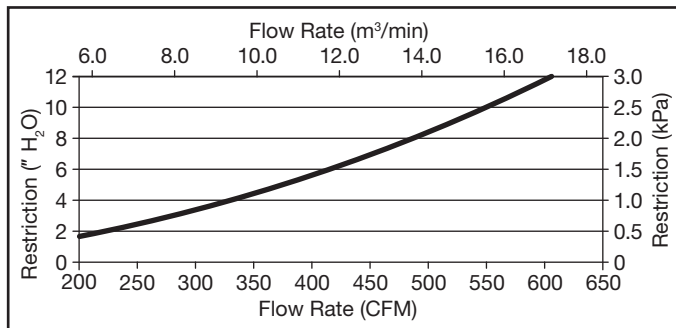

System Capacity vs Flow Rate

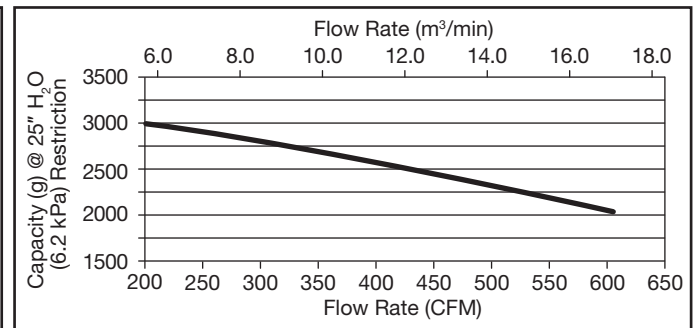

Restriction		Flow Rate		Typical Capacity at 25" H ₂ O (6.2 kPa) of Terminal Restriction
in H ₂ O	kPa	CFM	m³/min	Non Aspirated (g)
4	1.0	332	9.4	2728
6	1.5	416	11.8	2536
8	2.0	487	13.8	2359
10	2.5	549	15.6	2192
12	3.0	606	17.2	2033

ISO Fine Dust
1.0 g/m³ Feed Rate
25" H₂O (6.2 kPa)
Terminal Restriction
per ISO 5011

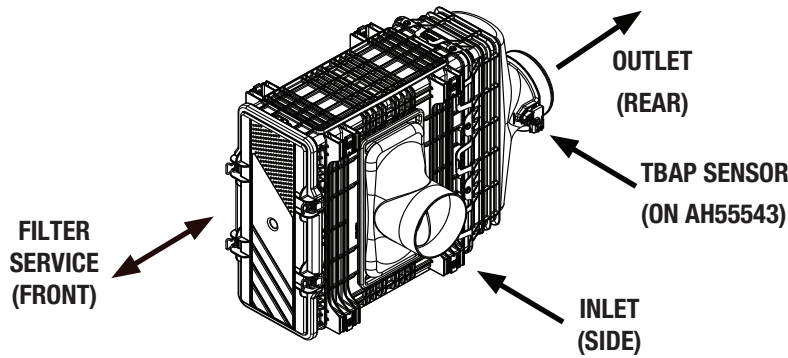

Specifications

Specification	AH55543 • AH55556
Length, Overall	24.8" (632 mm)
Width, Overall	12.7" (323 mm)
Height, Overall	17.7" (450 mm)
Flow, Min. at 2" H ₂ O (0.5 kPa) Restriction	235 CFM (6.7 m ³ /min)
Flow, Max. at 12" H ₂ O (3.0 kPa) Restriction	635 CFM (18.0 m ³ /min)
Secondary Element	Yes
Housing Material	Glass-Filled Polyamide
Pre-Cleaner	No
Inlet	90° to Outlet, 5" (127 mm)
Outlet	Straight, 5" (127 mm)
Filter Efficiency	≥ 99.90% per ISO 5011

Specifications subject to change without notice.

Dust Holding Capacity per Flow Rate

Specification	Non Aspirated	
	CFM	m ³ /min
Maximum Flow for 10 g/CFM (3500 g/m ³ /min)	280	7.9
Maximum Flow for 25 g/CFM (8750 g/m ³ /min)	N/A*	N/A*

*Requires precleaner (optional)

Dimensions

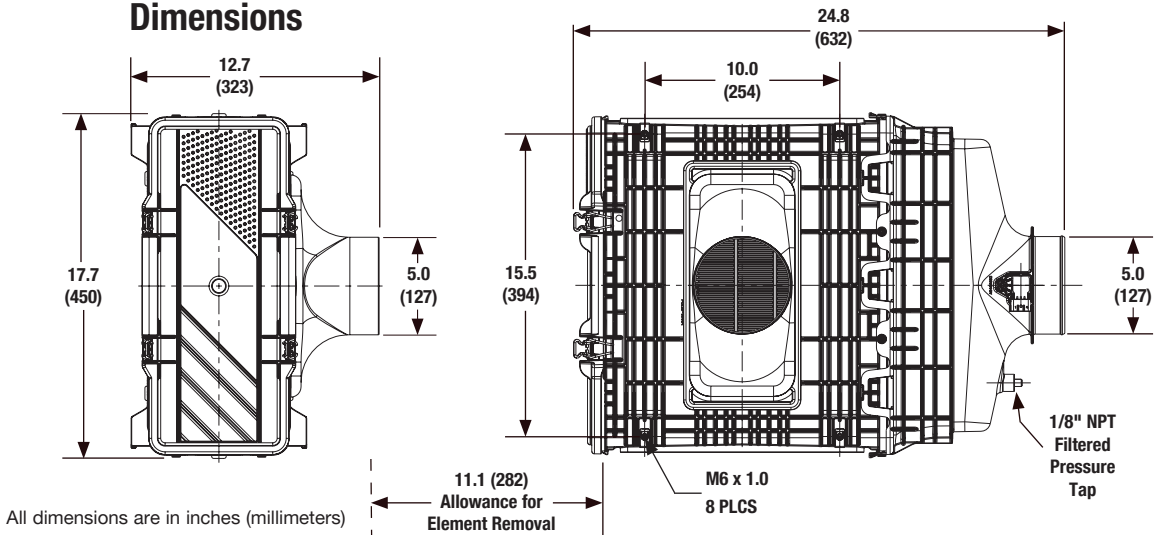

All dimensions are in inches (millimeters)

Ordering Information

Air Cleaners	
Part Number	Description
AH55543	Direct Flow - Side Inlet - With TBAP Sensor
AH55556	Direct Flow - Side Inlet - Without TBAP Sensor

Service Parts	
Part Number	Description
AF55014	Primary Element
AF55308	Secondary Element
SP1004	Service Kit: DEV Tube, DEV Cap, J-Clips (4)
SP1400	Service Cover with O-Ring

Optional Accessories	
Part Number	Description
3316658S	4" Band Clamp
3316660S	5" Band Clamp
3316608S	4" Hump hose
3316610S	5" Hump Hose
3316568S	4" 90° Elbow
3316570S	5" 90° Elbow
3316618S	5" to 4" Hump Hose Reducer
3946329S	Restriction Indicator

Additional sizes/shapes may be available.
Refer to the Cummins Filtration catalog or website.

Performance

System Restriction vs Flow Rate

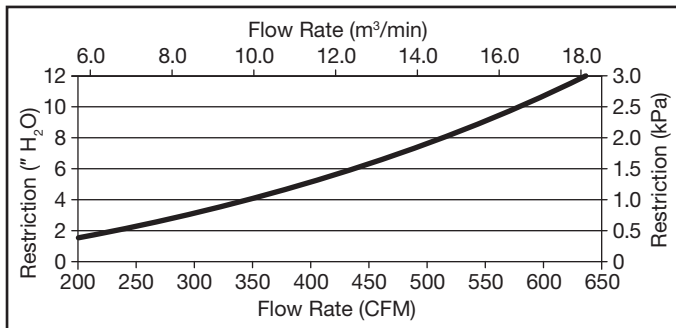

System Capacity vs Flow Rate

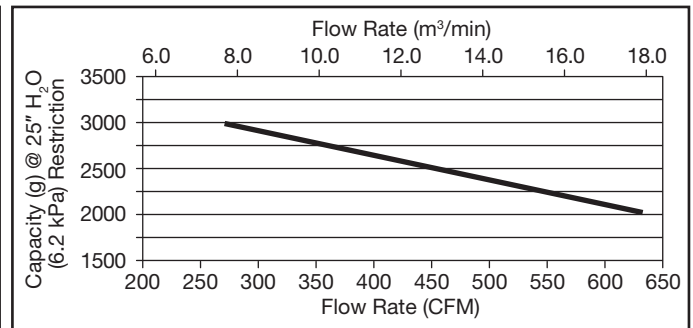

Restriction		Flow Rate		Typical Capacity at 25" H ₂ O (6.2 kPa) of Terminal Restriction
in H ₂ O	kPa	CFM	m³/min	Non Aspirated (g)
4	1.0	347	9.8	2754
6	1.5	436	12.3	2619
8	2.0	511	14.5	2433
10	2.5	576	16.3	2215
12	3.0	635	18.0	1973

ISO Fine Dust
1.0 g/m³ Feed Rate
25" H₂O (6.2 kPa)
Terminal Restriction
per ISO 5011

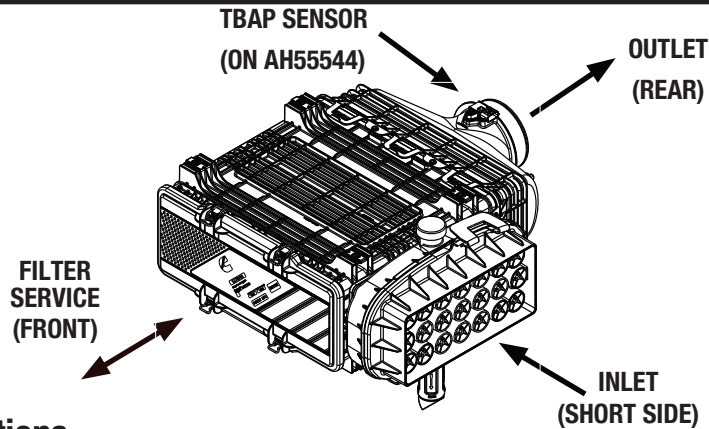

Specifications

Specification	AH55544 • AH55560
Length, Overall	24.8" (632 mm)
Width, Overall	14.8" (377 mm)
Height, Overall	22.3" (568 mm)
Flow, Min. at 2" H ₂ O (0.5 kPa) Restriction	190 CFM (5.4 m ³ /min)
Flow, Max. at 12" H ₂ O (3.0 kPa) Restriction	515 CFM (14.6 m ³ /min)
Secondary Element	Yes
Housing Material	Glass-Filled Polyamide
Pre-Cleaner	Integral, Spinner-tube Type
Inlet	Via Pre-Cleaner
Outlet	Straight, 5.0" (127 mm)
Filter Efficiency	≥ 99.90% per ISO 5011

Specifications subject to change without notice.

Dust Holding Capacity per Flow Rate

Specification	Aspirated		Non Aspirated	
	CFM	m ³ /min	CFM	m ³ /min
Maximum Flow for 10 g/CFM (3500 g/m ³ /min)	515*	14.6*	515*	14.6*
Maximum Flow for 25 g/CFM (8750 g/m ³ /min)	515*	14.6*	380	10.8

*Indicates maximum recommended flow rate

Dimensions

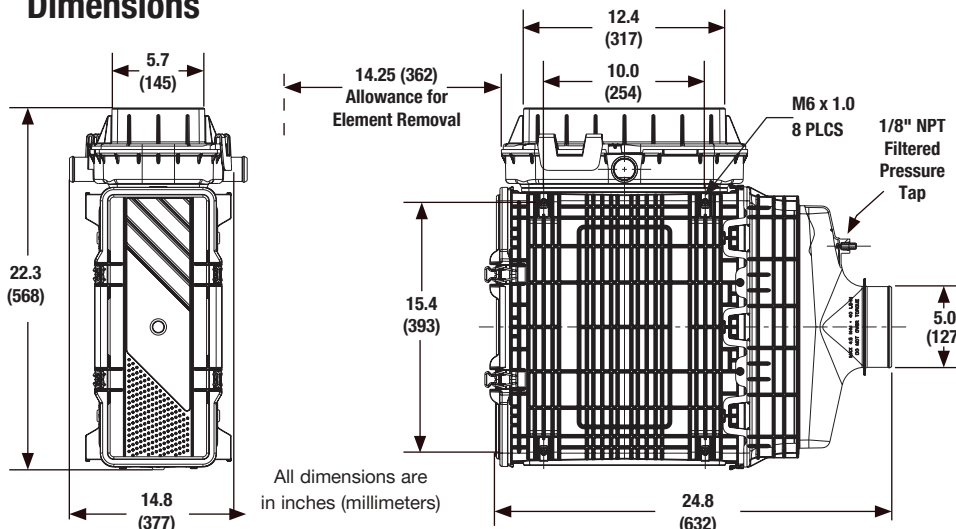

All dimensions are in inches (millimeters)

Ordering Information

Air Cleaners	
Part Number	Description
AH55544	Direct Flow - Integrated Pre-Cleaner - Side Inlet - With TBAP Sensor
AH55560	Direct Flow - Integrated Pre-Cleaner - Side Inlet - Without TBAP Sensor

Service Parts	
Part Number	Description
AF55014	Primary Element
AF55308	Secondary Element
SP1004	Service Kit: DEV Tube, DEV Cap, J-Clips (4)
SP1400	Service Cover with O-Ring

Optional Accessories	
Part Number	Description
3316658S	4" Band Clamp
3316660S	5" Band Clamp
3316608S	4" Hump hose
3316610S	5" Hump Hose
3316568S	4" 90° Elbow
3316570S	5" 90° Elbow
3316618S	5" to 4" Hump Hose Reducer
3946329S	Restriction Indicator

Additional sizes/shapes may be available. Refer to the Cummins Filtration catalog or website.

Performance

System Restriction vs Flow Rate

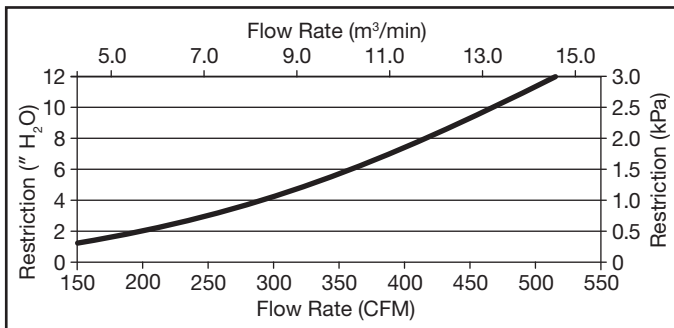

System Capacity vs Flow Rate

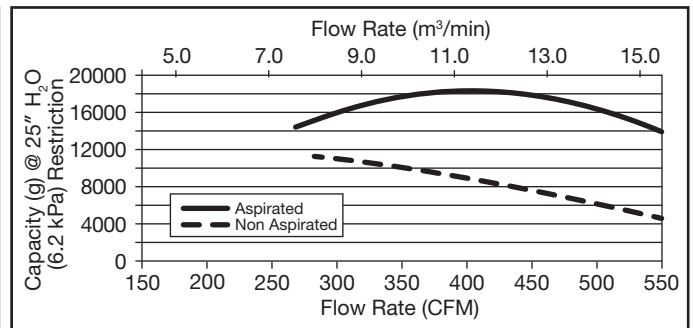

Restriction		Flow Rate		Typical Capacity at 25" H ₂ O (6.2 kPa) of Terminal Restriction	
in H ₂ O	kPa	CFM	m³/min	Aspirated (g)	Non Aspirated (g)
4	1.0	289	8.2	15074	11213
6	1.5	359	10.2	17732	9922
8	2.0	417	11.8	18373	8568
10	2.5	469	13.3	17725	7173
12	3.0	515	14.6	16159	5750

ISO Coarse Dust
2.0 g/m³ Feed Rate
25" H₂O (6.2 kPa)
Terminal Restriction
per ISO 5011

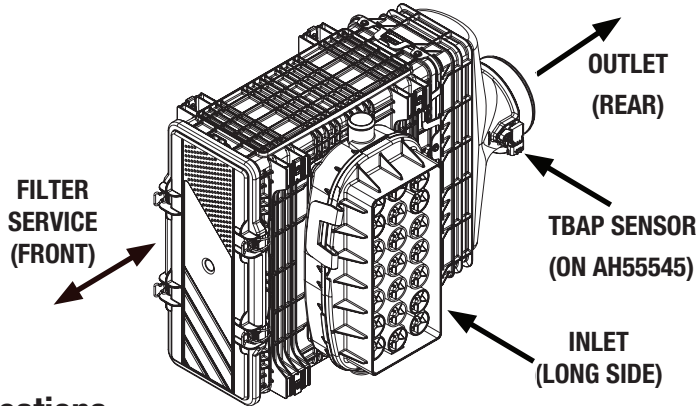

Specifications

Specification	AH55545 • AH55557
Length, Overall	24.8" (632 mm)
Width, Overall	12.9" (330 mm)
Height, Overall	21.6" (549 mm)
Flow, Min. at 2" H ₂ O (0.5 kPa) Restriction	200 CFM (5.7 m ³ /min)
Flow, Max. at 12" H ₂ O (3.0 kPa) Restriction	524 CFM (14.8 m ³ /min)
Secondary Element	Yes
Housing Material	Glass-Filled Polyamide
Pre-Cleaner	Integral, Spinner-tube Type
Inlet	Via Pre-Cleaner
Outlet	Straight, 5.0" (127 mm)
Filter Efficiency	≥ 99.90% per ISO 5011

Specifications subject to change without notice.

Dust Holding Capacity per Flow Rate

Specification	Aspirated		Non Aspirated	
	CFM	m ³ /min	CFM	m ³ /min
Maximum Flow for 10 g/CFM (3500 g/m ³ /min)	524*	14.8*	524*	14.8*
Maximum Flow for 25 g/CFM (8750 g/m ³ /min)	524*	14.8*	460	13.0

*Indicates maximum recommended flow rate

Dimensions

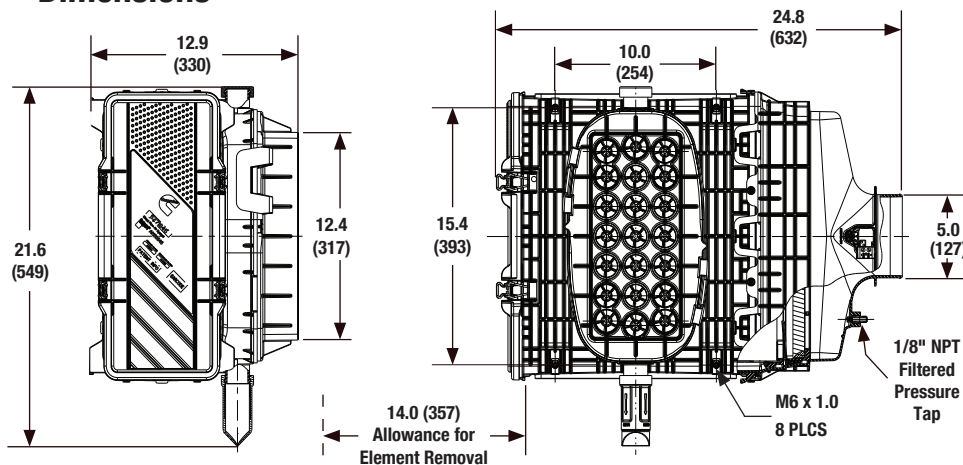

All dimensions are in inches (millimeters)

Ordering Information

Air Cleaners	
Part Number	Description
AH55545	Direct Flow - Integrated Pre-Cleaner - Side Inlet - With TBAP Sensor
AH55557	Direct Flow - Integrated Pre-Cleaner - Side Inlet - Without TBAP Sensor

Service Parts	
Part Number	Description
AF55014	Primary Element
AF55308	Secondary Element
SP1004	Service Kit: DEV Tube, DEV Cap, J-Clips (4)
SP1400	Service Cover with O-Ring

Optional Accessories	
Part Number	Description
3316658S	4" Band Clamp
3316660S	5" Band Clamp
3316608S	4" Hump hose
3316610S	5" Hump Hose
3316568S	4" 90° Elbow
3316570S	5" 90° Elbow
3316618S	5" to 4" Hump Hose Reducer
3946329S	Restriction Indicator

Additional sizes/shapes may be available. Refer to the Cummins Filtration catalog or website.

Performance

System Restriction vs Flow Rate

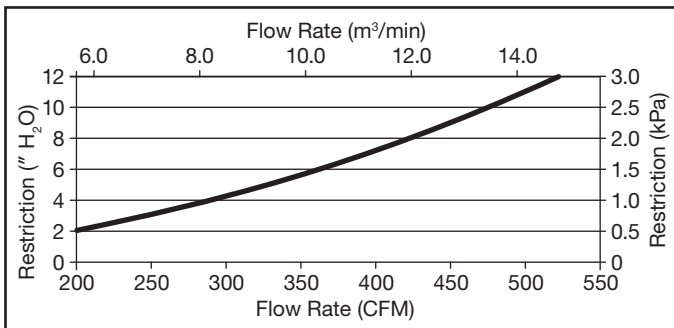

System Capacity vs Flow Rate

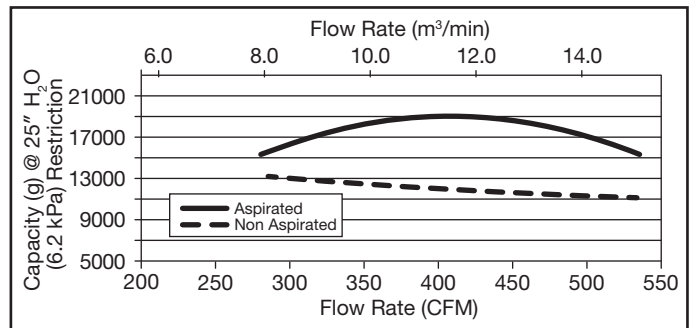

Restriction		Flow Rate		Typical Capacity at 25" H ₂ O (6.2 kPa) of Terminal Restriction	
in H ₂ O	kPa	CFM	m³/min	Aspirated (g)	Non Aspirated (g)
4	1.0	291	8.3	16211	13037
6	1.5	363	10.3	18777	12275
8	2.0	423	12.0	18929	11770
10	2.5	476	13.5	17876	11428
12	3.0	524	14.8	15862	11203

ISO Coarse Dust
2.0 g/m³ Feed Rate
25" H₂O (6.2 kPa)
Terminal Restriction
per ISO 5011

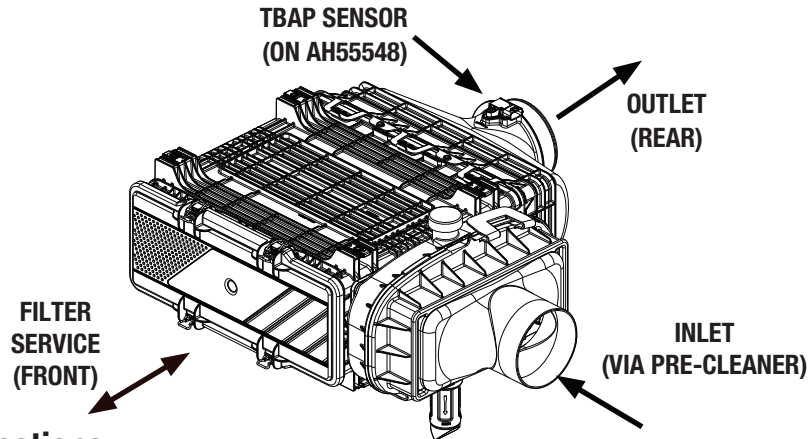

Specifications

Specification	AH55548 • AH55561
Length, Overall	24.9" (633 mm)
Width, Overall	14.8" (377 mm)
Height, Overall	27.0" (686 mm)
Flow, Min. at 2" H ₂ O (0.5 kPa) Restriction	170 CFM (4.8 m ³ /min)
Flow, Max. at 12" H ₂ O (3.0 kPa) Restriction	499 CFM (14.1 m ³ /min)
Secondary Element	Yes
Housing Material	Glass-Filled Polyamide
Pre-Cleaner	Integral, Spinner-tube Type
Inlet	90° to Outlet, 5.0" (127 mm)
Outlet	Straight, 5.0" (127 mm)
Filter Efficiency	≥ 99.90% per ISO 5011

Specifications subject to change without notice.

Dust Holding Capacity per Flow Rate

Specification	Aspirated		Non Aspirated	
	CFM	m ³ /min	CFM	m ³ /min
Maximum Flow for 10 g/CFM (3500 g/m ³ /min)	499*	14.1*	499*	14.1*
Maximum Flow for 25 g/CFM (8750 g/m ³ /min)	499*	14.1*	310	8.8

*Indicates maximum recommended flow rate

Dimensions

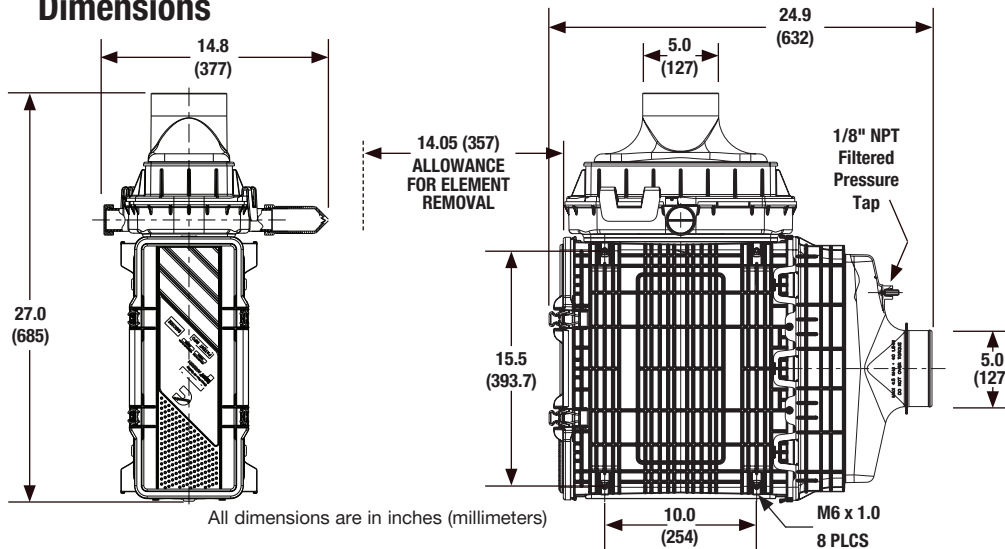

All dimensions are in inches (millimeters)

Ordering Information

Air Cleaners	
Part Number	Description
AH55548	Direct Flow - Integrated Pre-Cleaner - Side Inlet - With TBAP Sensor
AH55561	Direct Flow - Integrated Pre-Cleaner - Side Inlet - Without TBAP Sensor

Service Parts	
Part Number	Description
AF55014	Primary Element
AF55308	Secondary Element
SP1004	Service Kit: DEV Tube, DEV Cap, J-Clips (4)
SP1400	Service Cover with O-Ring

Optional Accessories	
Part Number	Description
3316658S	4" Band Clamp
3316660S	5" Band Clamp
3316608S	4" Hump hose
3316610S	5" Hump Hose
3316568S	4" 90° Elbow
3316570S	5" 90° Elbow
3316618S	5" to 4" Hump Hose Reducer
3946329S	Restriction Indicator

Additional sizes/shapes may be available. Refer to the Cummins Filtration catalog or website.

Performance

System Restriction vs Flow Rate

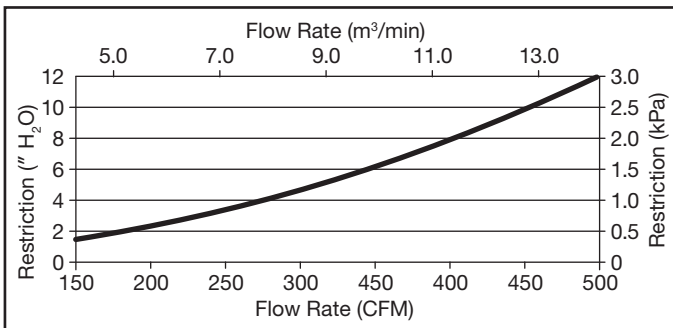

System Capacity vs Flow Rate

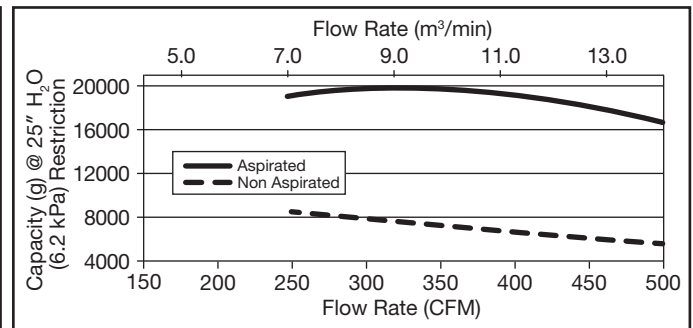

Restriction		Flow Rate		Typical Capacity at 25" H ₂ O (6.2 kPa) of Terminal Restriction	
in H ₂ O	kPa	CFM	m³/min	Aspirated (g)	Non Aspirated (g)
4	1.0	277	7.8	19468	8117
6	1.5	345	9.8	19751	7238
8	2.0	403	11.4	19233	6555
10	2.5	453	12.8	18204	5996
12	3.0	499	14.1	16632	5527

ISO Coarse Dust
2.0 g/m³ Feed Rate
25" H₂O (6.2 kPa)
Terminal Restriction
per ISO 5011

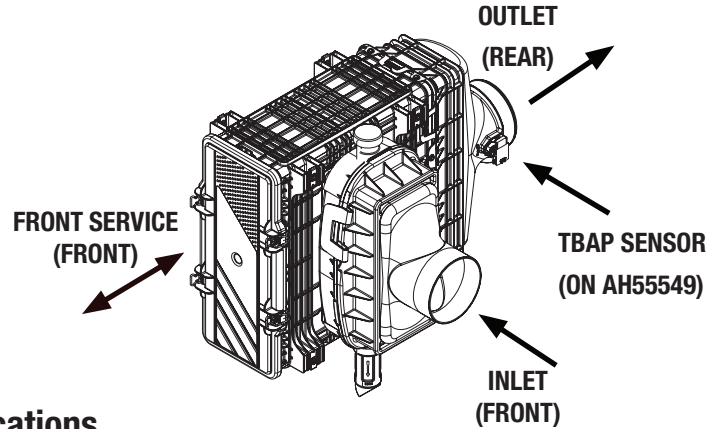

Specifications

Specification	AH55549 • AH55558
Length, Overall	24.9" (632 mm)
Width, Overall	17.6" (446 mm)
Height, Overall	21.6" (549 mm)
Flow, Min. at 2" H ₂ O (0.5 kPa) Restriction	170 CFM (4.8 m ³ /min)
Flow, Max. at 12" H ₂ O (3.0 kPa) Restriction	506 CFM (14.3 m ³ /min)
Secondary Element	Yes
Housing Material	Glass-Filled Polyamide
Pre-Cleaner	Yes
Inlet	90° to Outlet, 5.0" (127 mm)
Outlet	Straight, 5.0" (127 mm)
Filter Efficiency	≥ 99.90% per ISO 5011

Specifications subject to change without notice.

Dust Holding Capacity per Flow Rate

Specification	Aspirated		Non Aspirated	
	CFM	m ³ /min	CFM	m ³ /min
Maximum Flow for 10 g/CFM (3500 g/m ³ /min)	506*	14.3*	506*	14.3*
Maximum Flow for 25 g/CFM (8750 g/m ³ /min)	506*	14.3*	375	10.6

*Indicates maximum recommended flow rate

Dimensions

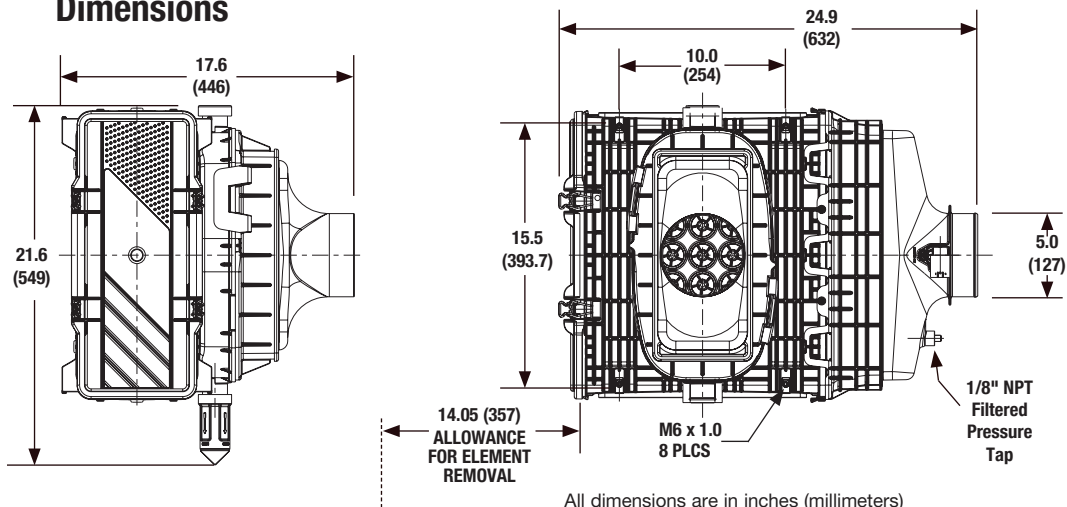

All dimensions are in inches (millimeters)

Ordering Information

Air Cleaners	
Part Number	Description
AH55549	Direct Flow - Integrated Pre-Cleaner - Side Inlet - With TBAP Sensor
AH55558	Direct Flow - Integrated Pre-Cleaner - Side Inlet - Without TBAP Sensor

Service Parts	
Part Number	Description
AF55014	Primary Element
AF55308	Secondary Element
SP1004	Service Kit: DEV Tube, DEV Cap, J-Clips (4)
SP1400	Service Cover with O-Ring

Optional Accessories	
Part Number	Description
3316658S	4" Band Clamp
3316660S	5" Band Clamp
3316608S	4" Hump hose
3316610S	5" Hump Hose
3316568S	4" 90° Elbow
3316570S	5" 90° Elbow
3316618S	5" to 4" Hump Hose Reducer
3946329S	Restriction Indicator

Additional sizes/shapes may be available. Refer to the Cummins Filtration catalog or website.

Performance

System Restriction vs Flow Rate

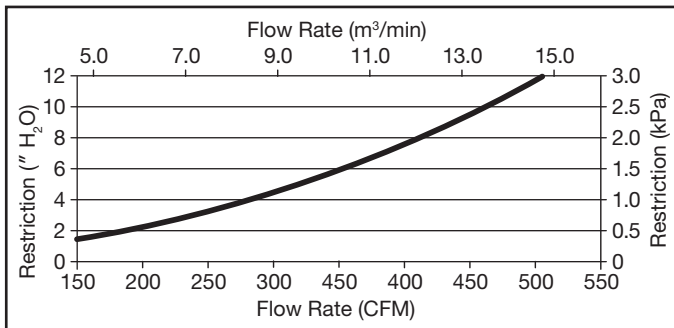

System Capacity vs Flow Rate

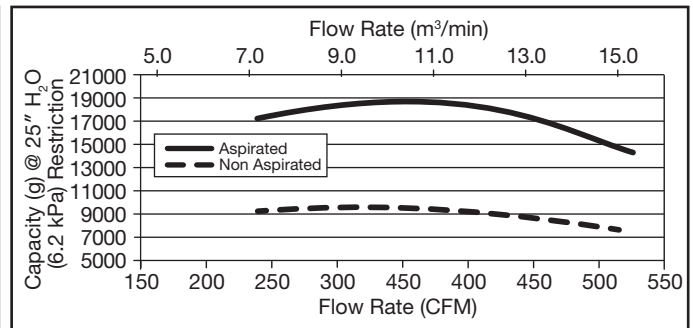

Restriction		Flow Rate		Typical Capacity at 25" H ₂ O (6.2 kPa) of Terminal Restriction	
in H ₂ O	kPa	CFM	m³/min	Aspirated (g)	Non Aspirated (g)
4	1.0	284	8.0	17737	9492
6	1.5	353	10.0	18730	9448
8	2.0	411	11.6	18557	9074
10	2.5	461	13.1	17634	8495
12	3.0	506	14.3	15210	7775

ISO Coarse Dust
2.0 g/m³ Feed Rate
25" H₂O (6.2 kPa)
Terminal Restriction
per ISO 5011

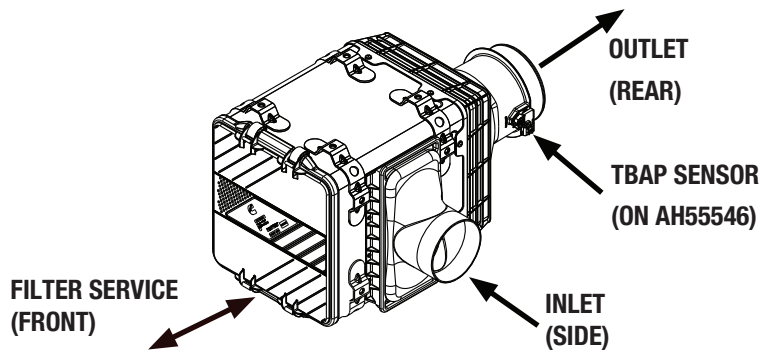

Specifications

Specification	AH55546 • AH55562
Length, Overall	25.0" (634.9 mm)
Width, Overall	18.5" (468.8 mm)
Height, Overall	14.6" (369.6 mm)
Flow, Min. at 2" H ₂ O (0.5 kPa) Restriction	270 CFM (7.7 m ³ /min)
Flow, Max. at 12" H ₂ O (3.0 kPa) Restriction	771 CFM (21.8 m ³ /min)
Secondary Element	Yes
Housing Material	Glass-Filled Polyamide and Metal
Pre-Cleaner	No
Inlet	90° to Outlet, 5.0" (127 mm)
Outlet	Straight, 6.0" (152 mm)
Filter Efficiency	≥ 99.90% per ISO 5011

Specifications subject to change without notice.

Dust Holding Capacity per Flow Rate

Specification	Non Aspirated	
	CFM	m ³ /min
Maximum Flow for 10 g/CFM (3500 g/m ³ /min)	380	10.8
Maximum Flow for 25 g/CFM (8750 g/m ³ /min)	N/A*	N/A*

*Requires precleaner (optional)

Dimensions

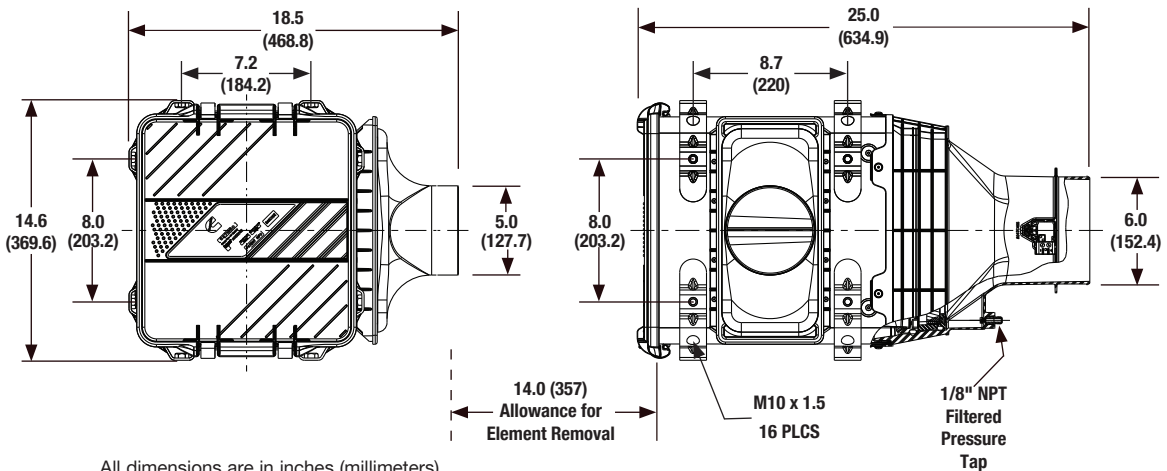

All dimensions are in inches (millimeters)

Ordering Information

Air Cleaners	
Part Number	Description
AH55546	Direct Flow - Side Inlet - With TBAP Sensor
AH55562	Direct Flow - Side Inlet - Without TBAP Sensor

TBAP -Temperature and Barometric Air Pressure

Service Parts	
Part Number	Description
AF55015	Primary Element
AF55309	Secondary Element
SP1003	Front Service Cover
SP1187	Service Cover Latches

Optional Accessories	
Part Number	Description
3316658S	4" Band Clamp
3316660S	5" Band Clamp
3316662S	6" Band Clamp
3316608S	4" Hump Hose
3316610S	5" Hump Hose
3316612S	6" Hump Hose
3316568S	4" 90° Elbow
3316570S	5" 90° Elbow
3316573S	6" 90° Elbow
3316589S	6" to 5" Reducing Elbow
3316618S	5" to 4" Hump Hose Reducer
3316621S	6" to 5" Hump Hose Reducer
3946466S	Weather Hood
3905161S	Restriction Indicator

Additional sizes/shapes may be available.
Refer to the Cummins Filtration catalog or website.

Performance

System Restriction vs Flow Rate

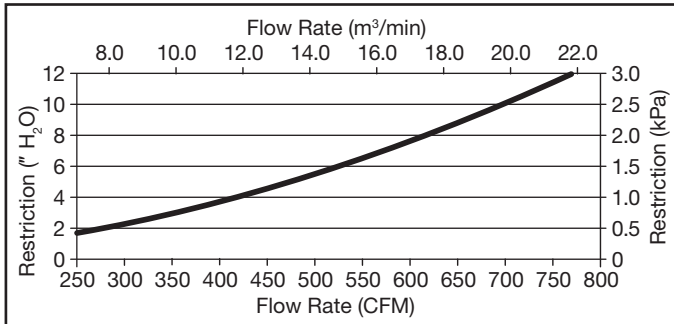

System Capacity vs Flow Rate

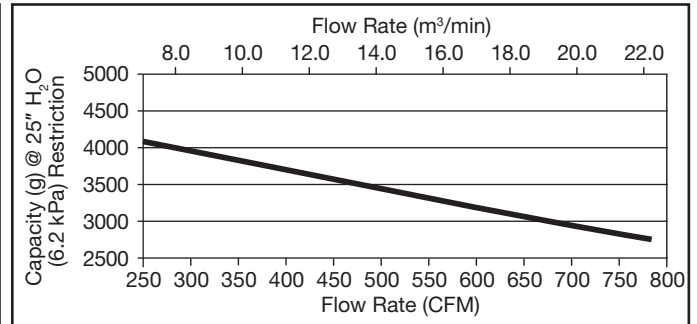

Restriction		Flow Rate		Typical Capacity at 25" H ₂ O (6.2 kPa) of Terminal Restriction
in H ₂ O	kPa	CFM	m³/min	Non Aspirated (g)
4	1.0	418	11.8	3645
6	1.5	526	14.9	3373
8	2.0	617	17.5	3146
10	2.5	698	19.8	2949
12	3.0	771	21.8	2772

ISO Fine Dust
1.0 g/m³ Feed Rate
25" H₂O (6.2 kPa)
Terminal Restriction
per ISO 5011

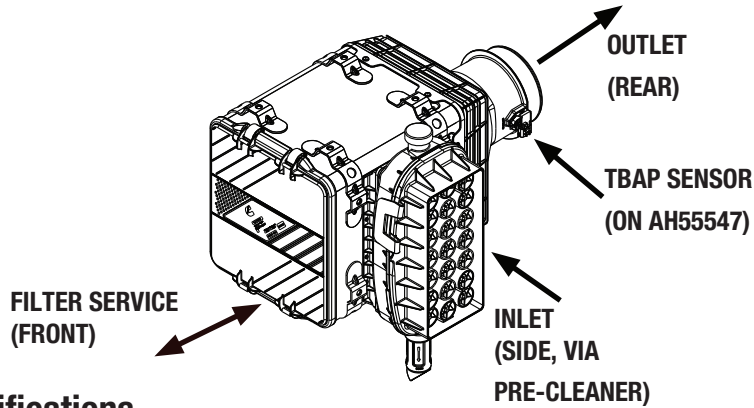

Specifications

Specification	AH55547 • AH55563
Length, Overall	25.0" (634.9 mm)
Width, Overall	18.7" (474.6 mm)
Height, Overall	21.6" (548.5 mm)
Flow, Min. at 2" H ₂ O (0.5 kPa) Restriction	260 CFM (7.4 m ³ /min)
Flow, Max. at 12" H ₂ O (3.0 kPa) Restriction	690 CFM (19.5 m ³ /min)
Secondary Element	Yes
Housing Material	Glass-Filled Polyamide and Metal
Pre-Cleaner	Integral, Spinner-tube Type
Inlet	Via Pre-Cleaner, 90° to outlet
Outlet	Straight, 6.0" (152 mm)
Filter Efficiency	≥ 99.90% per ISO 5011

Specifications subject to change without notice.

Dust Holding Capacity per Flow Rate

Specification	Aspirated		Non Aspirated	
	CFM	m ³ /min	CFM	m ³ /min
Maximum Flow for 10 g/CFM (3500 g/m ³ /min)	690*	19.5*	690*	19.5*
Maximum Flow for 25 g/CFM (8750 g/m ³ /min)	690*	19.5*	600	17.0

*Indicates maximum recommended flow rate

Dimensions

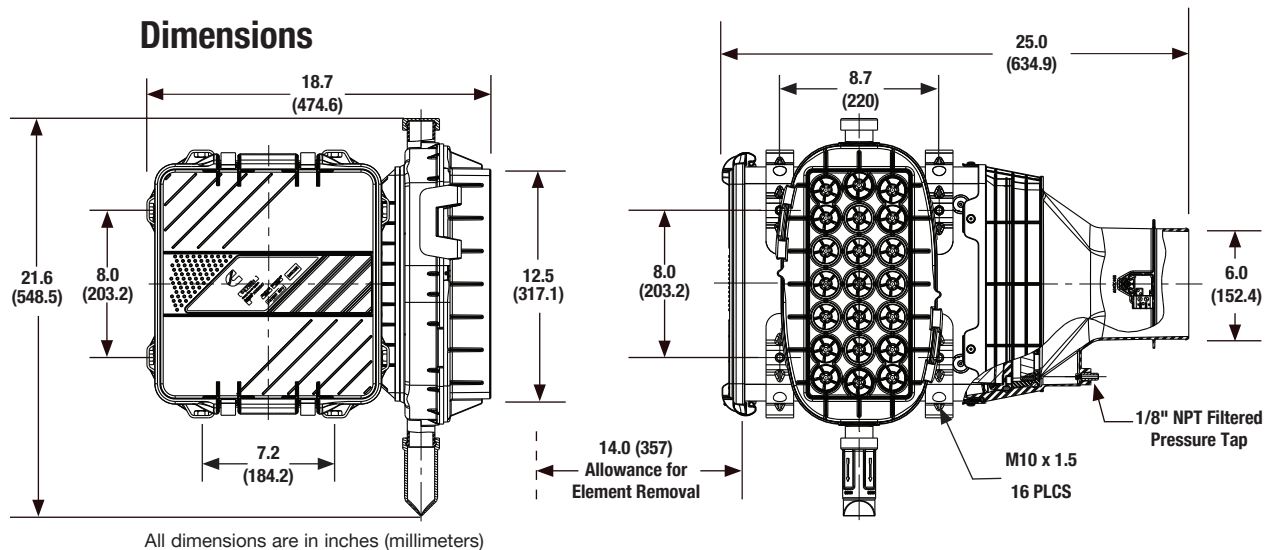

All dimensions are in inches (millimeters)

Ordering Information

Air Cleaners	
Part Number	Description
AH55547	Direct Flow - Side Inlet - Integrated Pre-Cleaner - With TBAP Sensor
AH55563	Direct Flow - Side Inlet - Integrated Pre-Cleaner - Without TBAP Sensor

TBAP -Temperature and Barometric Air Pressure

Service Parts	
Part Number	Description
AF55015	Primary Element
AF55309	Secondary Element
SP1003	Front Service Cover
SP1048	Angled Dust Ejection Valve (DEV)
SP1004	Service Kit: Straight DEV Tube, DEV Cap, J-Clips (4)
SP1187	Service Cover Latches

Optional Accessories	
Part Number	Description
3316658S	4" Band Clamp
3316660S	5" Band Clamp
3316662S	6" Band Clamp
3316608S	4" Hump Hose
3316610S	5" Hump Hose
3316612S	6" Hump Hose
3316568S	4" 90° Elbow
3316570S	5" 90° Elbow
3316573S	6" 90° Elbow
3316589S	6" to 5" Reducing Elbow
3316618S	5" to 4" Hump Hose Reducer
3316621S	6" to 5" Hump Hose Reducer
3946466S	Weather Hood
3905161S	Restriction Indicator

Additional sizes/shapes may be available. Refer to the Cummins Filtration catalog or website.

Performance

System Restriction vs Flow Rate

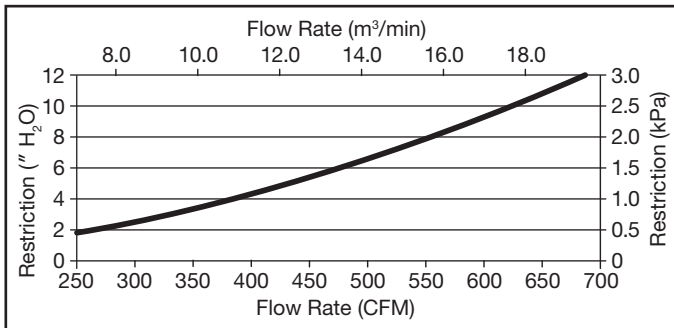

System Capacity vs Flow Rate

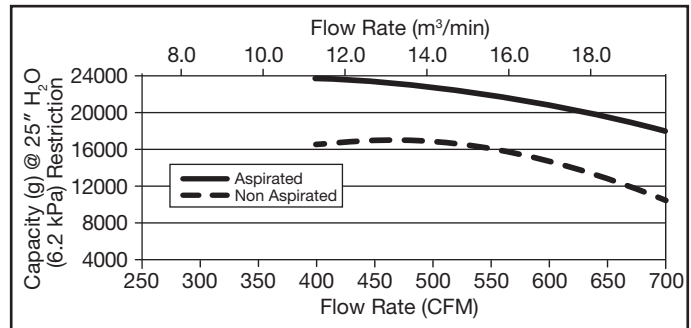

Restriction		Flow Rate		Typical Capacity at 25" H ₂ O (6.2 kPa) of Terminal Restriction	
in H ₂ O	kPa	CFM	m³/min	Aspirated (g)	Non Aspirated (g)
4	1.0	384	10.9	23206	16274
6	1.5	478	13.5	22996	16922
8	2.0	557	15.8	21723	15901
10	2.5	627	17.8	19767	13816
12	3.0	690	19.5	17324	10969

ISO Coarse Dust
2.0 g/m³ Feed Rate
25" H₂O (6.2 kPa)
Terminal Restriction
per ISO 5011

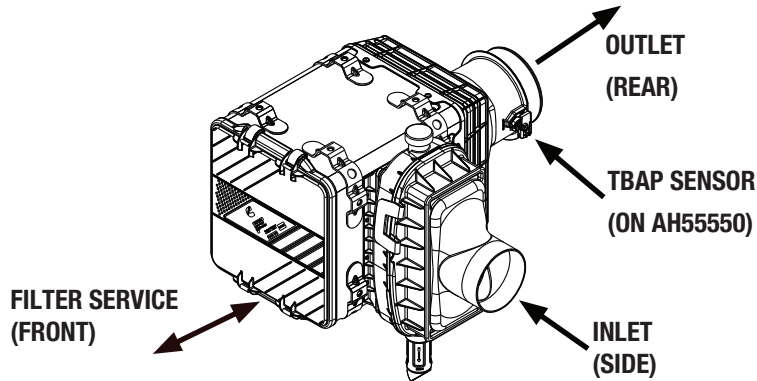

Specifications

Specification	AH55550 • AH55564
Length, Overall	25.0" (634.9 mm)
Width, Overall	23.4" (595.3 mm)
Height, Overall	21.6" (548.5 mm)
Flow, Min. at 2" H ₂ O (0.5 kPa) Restriction	240 CFM (6.80 m ³ /min)
Flow, Max. at 12" H ₂ O (3.0 kPa) Restriction	650 CFM (18.4 m ³ /min)
Secondary Element	Yes
Housing Material	Glass-Filled Polyamide and Metal
Pre-Cleaner	Integral, Vortex Tube Type
Inlet	90° to Outlet, 5.0" (127 mm)
Outlet	Straight, 6.0" (152.4 mm)
Filter Efficiency	≥ 99.90% per ISO 5011

Specifications subject to change without notice.

Dust Holding Capacity per Flow Rate

Specification	Aspirated		Non Aspirated	
	CFM	m ³ /min	CFM	m ³ /min
Maximum Flow for 10 g/CFM (3500 g/m ³ /min)	650*	18.4*	650*	18.4*
Maximum Flow for 25 g/CFM (8750 g/m ³ /min)	650*	18.4*	400	11.3

*Indicates maximum recommended flow rate

Dimensions

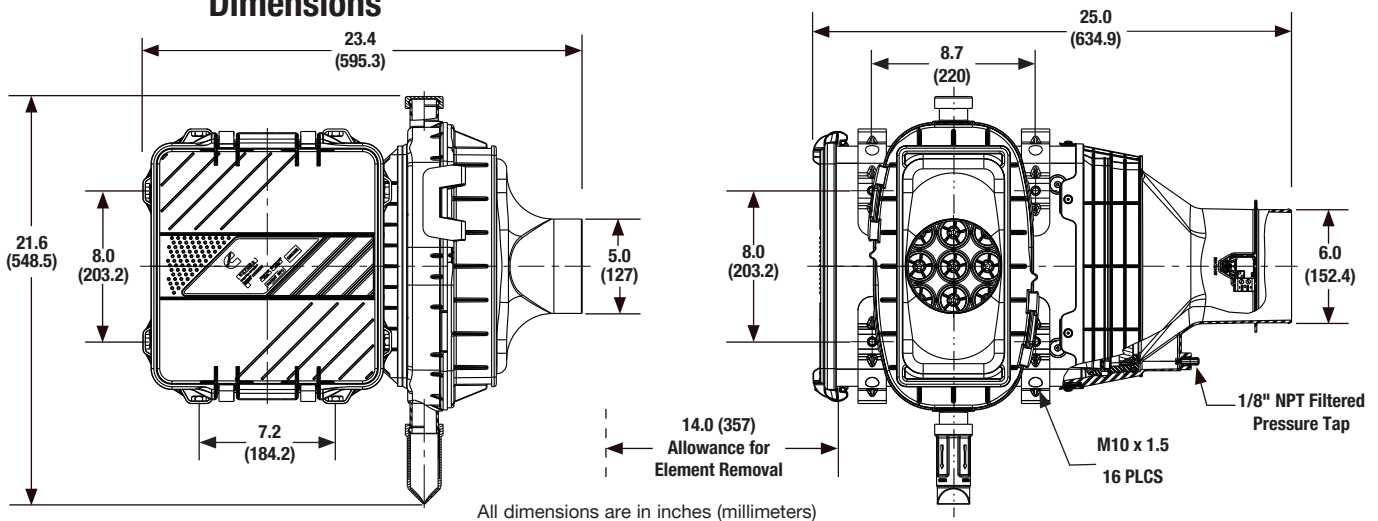

All dimensions are in inches (millimeters)

Ordering Information

Air Cleaners	
Part Number	Description
AH55550	Direct Flow - Integrated Pre-Cleaner - Side Inlet - With TBAP Sensor
AH55564	Direct Flow - Integrated Pre-Cleaner - Side Inlet - Without TBAP Sensor

TBAP -Temperature and Barometric Air Pressure

Service Parts	
Part Number	Description
AF55015	Primary Element
AF55309	Secondary Element
SP1003	Front Service Cover
SP1048	Angled Dust Ejection Valve (DEV)
SP1004	Service Kit: Straight DEV Tube, DEV Cap, J-Clips (4)
SP1187	Service Cover Latches

Optional Accessories	
Part Number	Description
3316658S	4" Band Clamp
3316660S	5" Band Clamp
3316662S	6" Band Clamp
3316608S	4" Hump Hose
3316610S	5" Hump Hose
3316612S	6" Hump Hose
3316568S	4" 90° Elbow
3316570S	5" 90° Elbow
3316573S	6" 90° Elbow
3316589S	6" to 5" Reducing Elbow
3316618S	5" to 4" Hump Hose Reducer
3316621S	6" to 5" Hump Hose Reducer
3946466S	Weather Hood
3905161S	Restriction Indicator

Additional sizes/shapes may be available. Refer to the Cummins Filtration catalog or website.

Performance

System Restriction vs Flow Rate

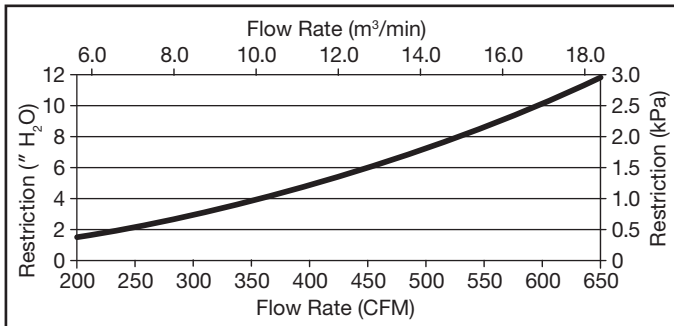

System Capacity vs Flow Rate

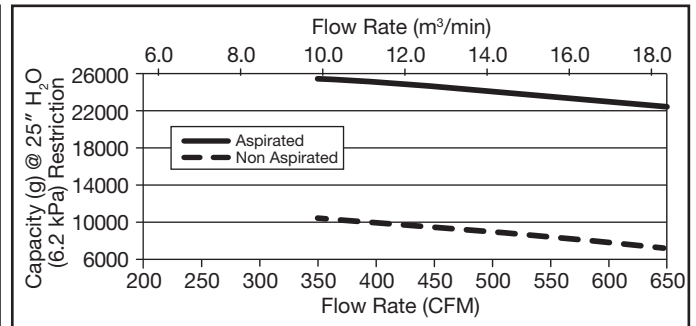

Restriction		Flow Rate		Typical Capacity at 25" H ₂ O (6.2 kPa) of Terminal Restriction	
" H ₂ O	kPa	CFM	m³/min	Aspirated (g)	Non Aspirated (g)
4	1.0	357	10.1	25446	10351
6	1.5	445	12.6	24668	9530
8	2.0	520	14.7	23906	8751
10	2.5	586	16.6	23153	8000
12	3.0	650	18.4	22407	7214

ISO Coarse Dust
2.0 g/m³ Feed Rate
25" H₂O (6.2 kPa)
Terminal Restriction
per ISO 5011

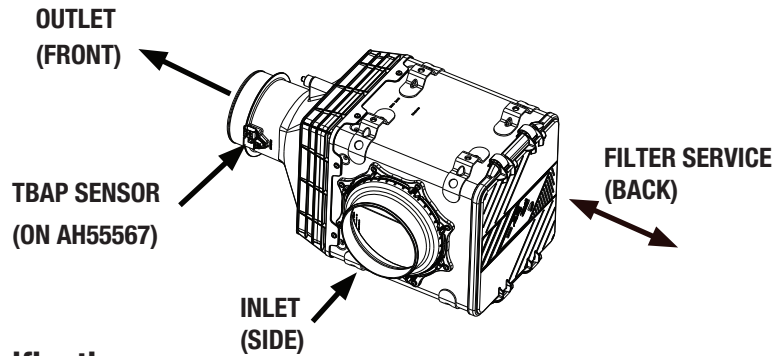

Specifications

Specification	AH55676 • AH55677
Length, Overall	25.4" (644.2 mm)
Width, Overall	15.2" (386.9 mm)
Height, Overall	14.6" (369.6 mm)
Flow, Min. at 2" H ₂ O (0.5 kPa) Restriction	340 CFM (9.6 m ³ /min)
Flow, Max. at 12" H ₂ O (3.0 kPa) Restriction	1000 CFM (28.3 m ³ /min)
Secondary Element	Yes
Housing Material	Glass-Filled Polyamide and Metal
Pre-Cleaner	No
Inlet	90° to Outlet, 7.0" (178 mm)
Outlet	Straight, 6.0" (152 mm)
Filter Efficiency	≥ 99.90% per ISO 5011

Specifications subject to change without notice.

Dust Holding Capacity per Flow Rate

Specification	Non Aspirated	
	CFM	m ³ /min
Maximum Flow for 10 g/CFM (3500 g/m ³ /min)	270	7.6
Maximum Flow for 25 g/CFM (8750 g/m ³ /min)	N/A*	N/A*

*Requires precleaner (optional)

Dimensions

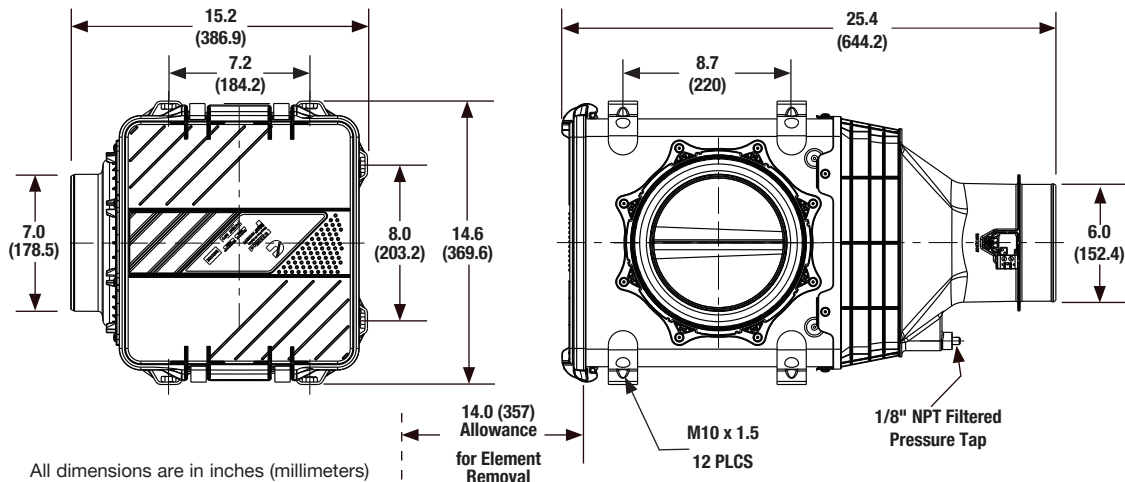

All dimensions are in inches (millimeters)

Ordering Information

Air Cleaners	
Part Number	Description
AH55676	Direct Flow - Side Inlet - Without TBAP Sensor
AH55677	Direct Flow - Side Inlet - With TBAP Sensor

TBAP -Temperature and Barometric Air Pressure

Service Parts	
Part Number	Description
AF55015	Primary Element
AF55309	Secondary Element
SP1003	Front Service Cover
SP1187	Service Cover Latches

Optional Accessories	
Part Number	Description
3316658S	4" Band Clamp
3316660S	5" Band Clamp
3316662S	6" Band Clamp
3316608S	4" Hump Hose
3316610S	5" Hump Hose
3316612S	6" Hump Hose
3316568S	4" 90° Elbow
3316570S	5" 90° Elbow
3316573S	6" 90° Elbow
3316589S	6" to 5" Reducing Elbow
3316618S	5" to 4" Hump Hose Reducer
3316621S	6" to 5" Hump Hose Reducer

Additional sizes/shapes may be available.
Refer to the Cummins Filtration catalog or website.

Performance

System Restriction vs Flow Rate

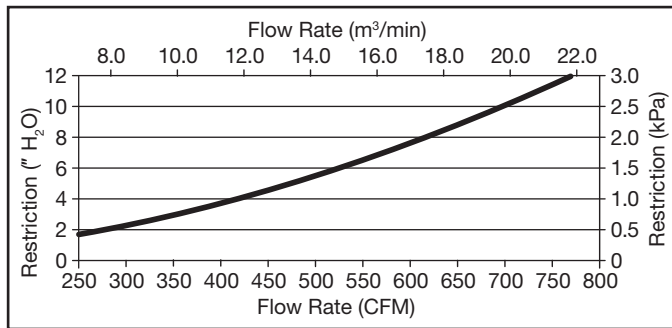

System Capacity vs Flow Rate

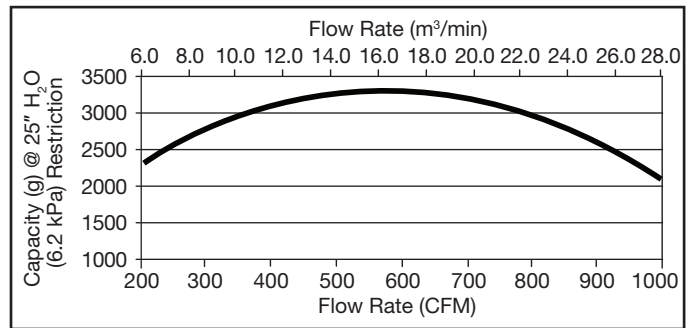

Restriction		Flow Rate		Typical Capacity at 25" H ₂ O (6.2 kPa) of Terminal Restriction
in H ₂ O	kPa	CFM	m³/min	Non-Aspirated (g)
4	1.0	540	15.3	3300
6	1.5	680	19.3	3200
8	2.0	800	22.7	3050
10	2.5	900	25.5	2550
12	3.0	1000	28.3	1900

ISO Fine Dust
1.0 g/m³ Feed Rate
25" H₂O (6.2 kPa)
Terminal Restriction
per ISO 5011

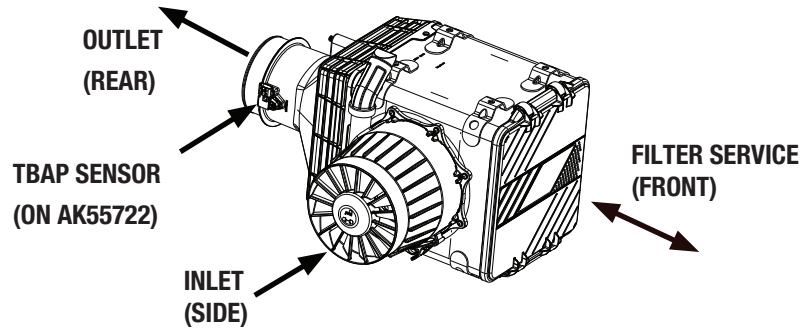

Specifications

Specification	AK55722 • AK55723
Length, Overall	25.4" (644.2 mm)
Width, Overall	14.6" (369.6 mm)
Height, Overall	21.1" (534.9 mm)
Flow, Min. at 2" H ₂ O (0.5 kPa) Restriction	300 CFM (8.5 m ³ /min)
Flow, Max. at 12" H ₂ O (3.0 kPa) Restriction	825 CFM (23.4 m ³ /min)
Secondary Element	Yes
Housing Material	Glass-Filled Polyamide and Metal
Pre-Cleaner	No
Inlet	90° to Outlet, 8.0" (203 mm)
Outlet	Straight, 6.0" (152 mm)
Filter Efficiency	≥ 99.90% per ISO 5011

Specifications subject to change without notice.

Dust Holding Capacity per Flow Rate

Specification	CFM	m ³ /min
Maximum Flow for 10 g/CFM (3500 g/m ³ /min)	825*	23.4*
Maximum Flow for 25 g/CFM (8750 g/m ³ /min)	380	10.8

*Indicates maximum recommended flow rate

Dimensions

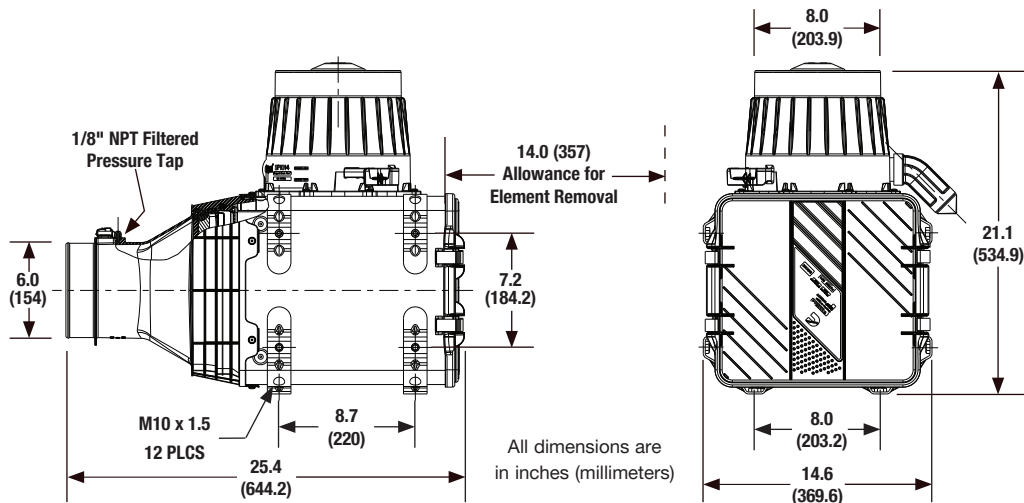

Ordering Information

Air Cleaners		Service Parts		Optional Accessories	
Part Number	Description	Part Number	Description	Part Number	Description
AK55722	Direct Flow - Side Inlet - Integrated Pre-Cleaner - With TBAP Sensor	AF55015	Primary Element	3316658S	4" Band Clamp
	AK55723	Direct Flow - Side Inlet - Integrated Pre-Cleaner - Without TBAP Sensor	AF55309	Secondary Element	3316660S
			SP1003	Front Service Cover	3316662S
		SP1048	Angled Dust Ejection Valve (DEV)	3316608S	4" Hump Hose
		SP1014	Pre-Cleaner Assembly	3316610S	5" Hump Hose
		SP1187	Service Cover Latches	3316612S	6" Hump Hose
				3316568S	4" 90° Elbow
				3316570S	5" 90° Elbow
				3316573S	6" 90° Elbow
				3316589S	6" to 5" Reducing Elbow
				3316618S	5" to 4" Hump Hose Reducer
				3316621S	6" to 5" Hump Hose Reducer
				3946466S	Weather Hood
				3905161S	Restriction Indicator

TBAP -Temperature and Barometric Air Pressure

Additional sizes/shapes may be available.
Refer to the Cummins Filtration catalog or website.

Performance

System Restriction vs Flow Rate

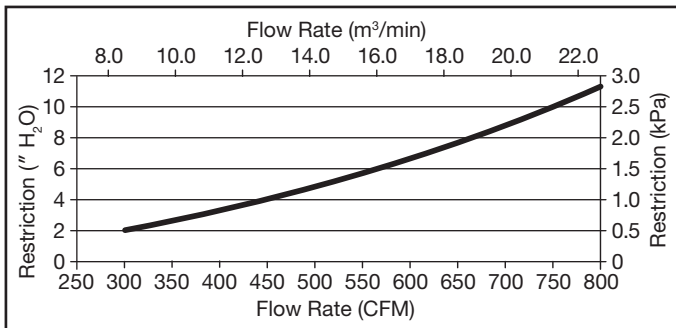

System Capacity vs Flow Rate

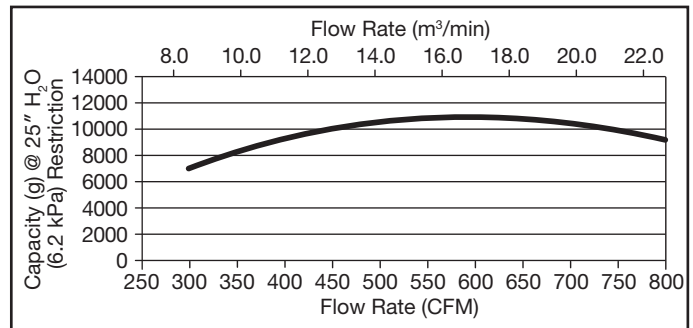

Restriction		Flow Rate		Typical Capacity at 25" H ₂ O (6.2 kPa) of Terminal Restriction
in H ₂ O	kPa	CFM	m³/min	Non-Aspirated (g)
4	1.0	450	12.7	10000
6	1.5	560	15.9	10500
8	2.0	670	19.0	10800
10	2.5	750	21.2	10000
12	3.0	825	23.4	8800

ISO Coarse Dust
2.0 g/m³ Feed Rate
25" H₂O (6.2 kPa)
Terminal Restriction
per ISO 5011

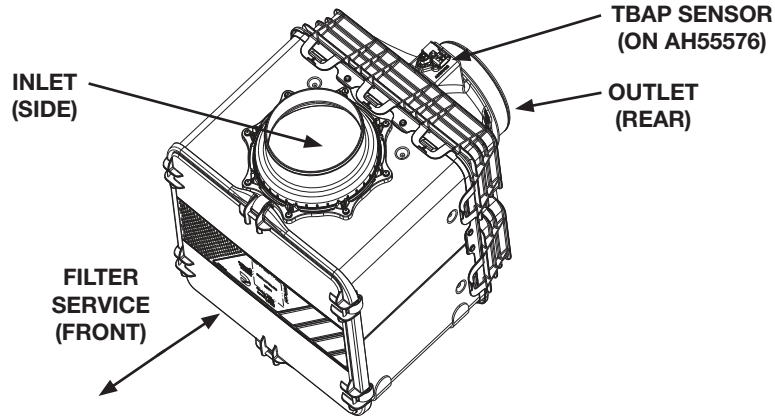

Specifications

Specification	AH55576 - AH55674
Length, Overall	21.6" (548.3 mm)
Width, Overall	17.4" (441.2 mm)
Height, Overall	18.4" (466.5 mm)
Flow, Min. at 2" H ₂ O (0.5 kPa) Restriction	425 CFM (12.0 m ³ /min)
Flow, Max. at 12" H ₂ O (3.0 kPa) Restriction	1190 CFM (33.7 m ³ /min)
Secondary Element	Yes
Housing Material	Glass-Filled Polyamide / Metal
Pre-Cleaner	No
Inlet	Straight 7.0" (177.8 mm)
Outlet	Straight 7.1" (179.4 mm)
Filter Efficiency	≥ 99.90% per ISO 5011

Specifications subject to change without notice.

Dust Holding Capacity per Flow Rate

Specification	Non Aspirated	
	CFM	m ³ /min
Maximum Flow for 10 g/CFM (3500 g/m ³ /min)	600	16.8
Maximum Flow for 25 g/CFM (8750 g/m ³ /min)	N/A*	N/A*

* Requires Pre-Cleaner (optional) .

Dimensions

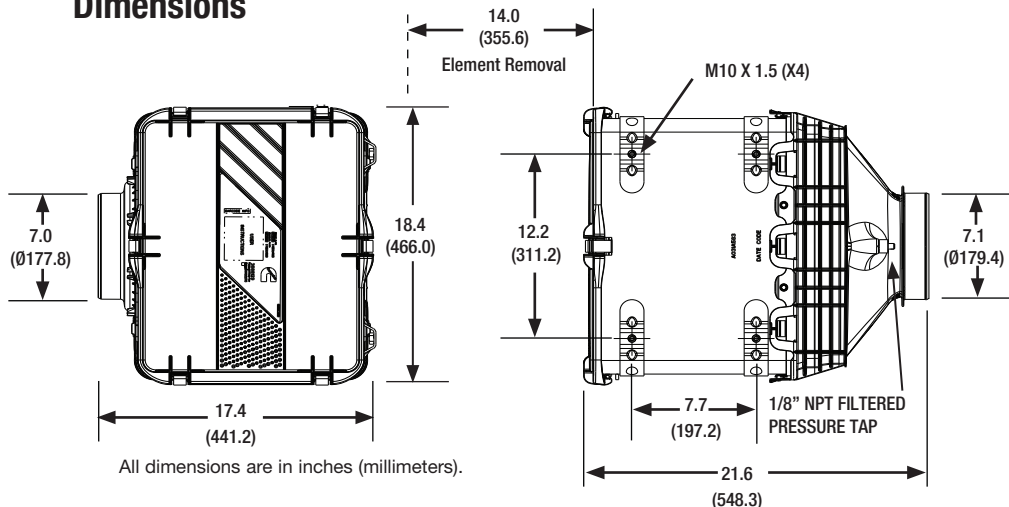

Ordering Information

Air Cleaners	
Part Number	Description
AH55576	Direct Flow - Long Side Inlet - With TBAP Sensor
AH55674	Direct Flow - Long Side Inlet - Without TBAP Sensor

TBAP -Temperature and Barometric Air Pressure

Service Parts	
Part Number	Description
AF55014	Primary Element (2 REQ)
AF55308	Secondary Element (2 REQ)
SP1013	Service Cover
SP1187	Service Cover Latches
SP1048	Dust Ejection Valve (DEV)

Optional Accessories	
Part Number	Description
3316663S	7" Band Clamp
3316613S	7" Hump Hose
3316586S	7" 45° Elbow
3316576S	7" 90° Elbow
3316624S	7" to 6" Hump Hose Reducer
3316593S	7" to 5.5" 90° Reducing Elbow
3316591S	7" to 5" 90° Reducing Elbow
3946329S	Restriction Indicator

Additional sizes/shapes may be available. Refer to the Cummins Filtration catalog or website.

Performance

System Restriction vs Flow Rate

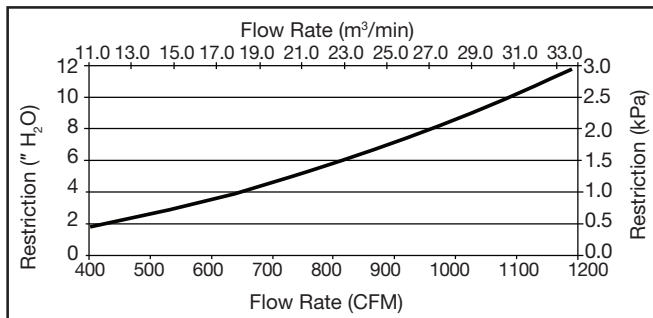

System Capacity vs Flow Rate

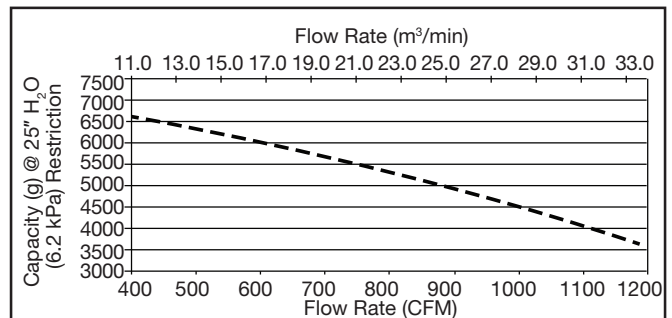

Restriction		Flow Rate		Typical Capacity at 25" H ₂ O (6.2 kPa) of Terminal Restriction
in H ₂ O	kPa	CFM	m³/min	
4	1.0	640	18.1	5900
6	1.5	820	23.2	5300
8	2.0	950	26.9	4750
10	2.5	1080	30.6	4200
12	3.0	1190	33.7	3600

ISO Fine Dust
1.0 g/m³ Feed Rate
25" H₂O (6.2 kPa)
Terminal Restriction
per ISO 5011

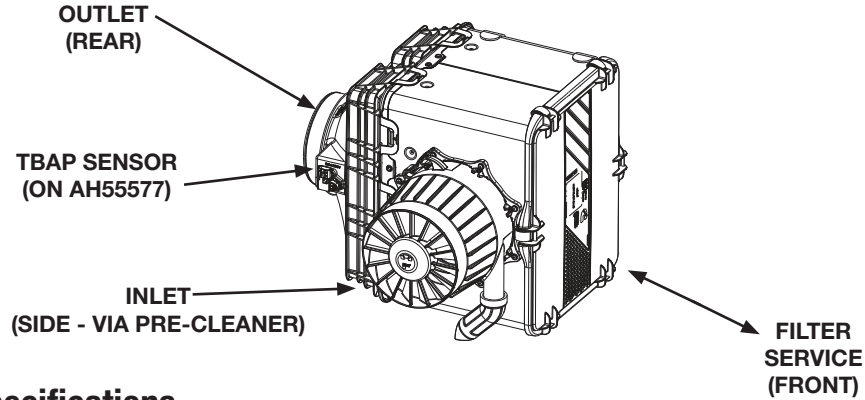

Specifications

Specification	AH55577 - AH55675
Length, Overall	21.6" (548.3 mm)
Width, Overall	23.1" (588.2 mm)
Height, Overall	18.3" (466.5 mm)
Flow, Min. at 2" H ₂ O (0.5 kPa) Restriction	325 CFM (9.2 m ³ /min)
Flow, Max. at 12" H ₂ O (3.0 kPa) Restriction	950 CFM (26.9 m ³ /min)
Secondary Element	Yes
Housing Material	Glass-Filled Polyamide
Pre-Cleaner	Integral Radial Fin Type
Inlet	Via Pre-Cleaner, 8.0" (203.0 mm)
Outlet	Straight, 7.0" (177.8 mm)
Filter Efficiency	≥ 99.90% per ISO 5011

Specifications subject to change without notice.

Dust Holding Capacity per Flow Rate

Specification	Aspirated		Non Aspirated	
	CFM	m ³ /min	CFM	m ³ /min
Maximum Flow for 10 g/CFM (3500 g/m ³ /min)	950*	26.9*	950*	26.9*
Maximum Flow for 25 g/CFM (8750 g/m ³ /min)	870	24.6	810	22.9

*indicates maximum recommended flow rate.

Dimensions

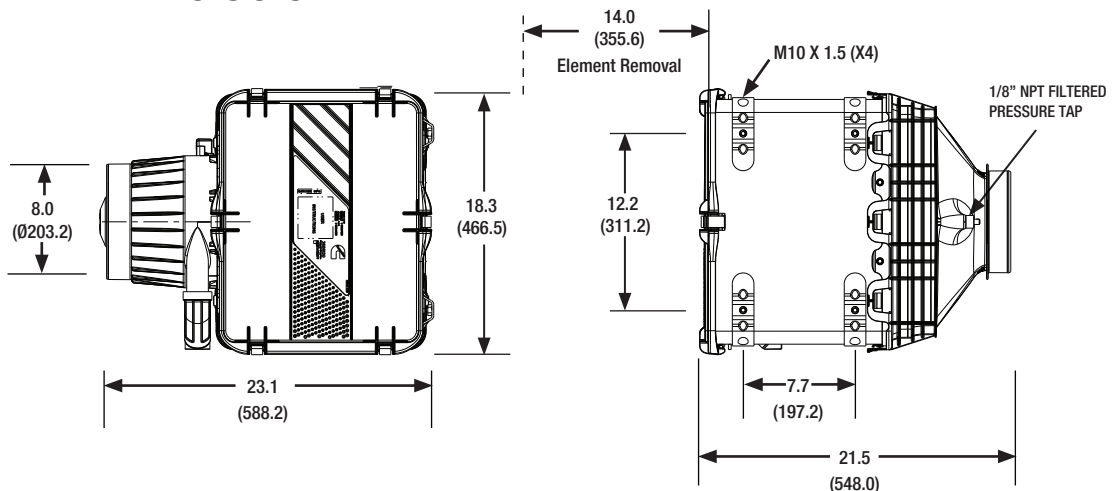

All dimensions are in inches (millimeters).

Ordering Information

Air Cleaners	
Part Number	Description
AH55577	Direct Flow - Integrated Pre-Cleaner - Long Side Inlet - With TBAP Sensor
AH55675	Direct Flow - Integrated Pre-Cleaner - Long Side Inlet - Without TBAP Sensor

TBAP -Temperature and Barometric Air Pressure

Service Parts	
Part Number	Description
AF55014	Primary Element (2 REQ)
AF55308	Secondary Element (2 REQ)
SP1013	Service Cover
SP1014	Pre-Cleaner With DEV
SP1048	Dust Ejection Valve (DEV)
SP1187	Service Cover Latches

Optional Accessories	
Part Number	Description
3316663S	7" Band Clamp
3316613S	7" Hump Hose
3316586S	7" 45° Elbow
3316576S	7" 90° Elbow
3316624S	7" to 6" Hump Hose Reducer
3316593S	7" to 5.5" 90° Reducing Elbow
3316591S	7" to 5" 90° Reducing Elbow
3946329S	Restriction Indicator

Additional sizes/shapes may be available. Refer to the Cummins Filtration catalog or website.

Performance

System Restriction vs Flow Rate

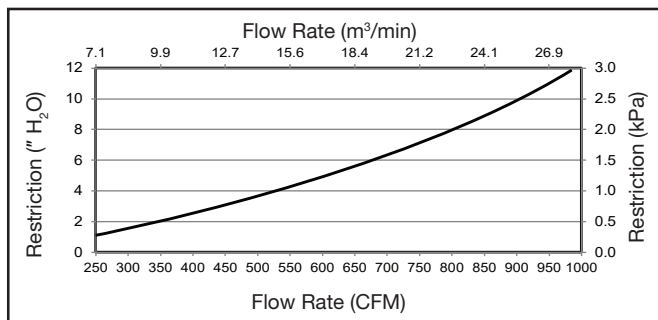

System Capacity vs Flow Rate

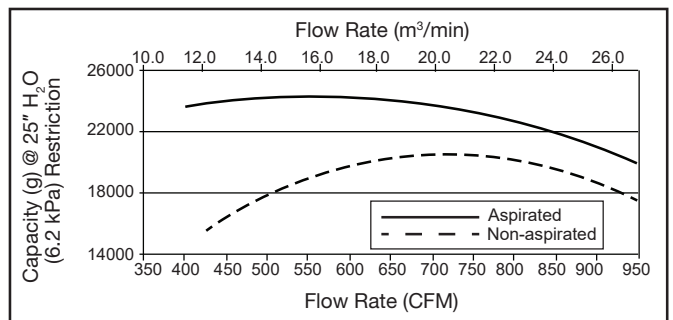

Restriction		Flow Rate		Typical Capacity at 25" H ₂ O (6.2 kPa) of Terminal Restriction	
in H ₂ O	kPa	CFM	m³/min	Aspirated (g)	Non Aspirated (g)
4	1.0	525	14.9	24100	18300
6	1.5	655	18.6	24000	20100
8	2.0	770	21.8	23000	20400
10	2.5	860	24.4	21800	19500
12	3.0	950	26.9	19800	17500

ISO Coarse Dust
2.0 g/m³ Feed Rate
25" H₂O (6.2 kPa)
Terminal Restriction
per ISO 5011

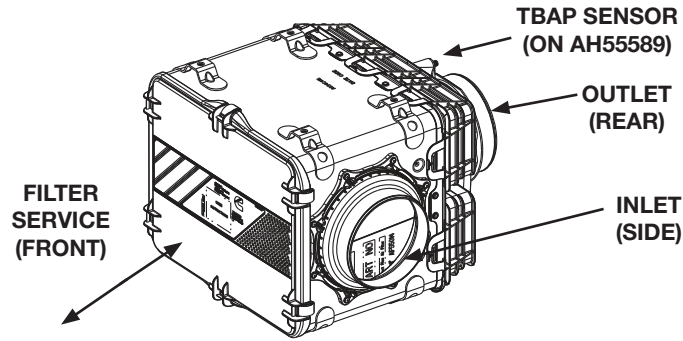

Specifications

Specification	AH55589 - AH55673
Length, Overall	21.6" (548.3 mm)
Width, Overall	15.6" (397.0 mm)
Height, Overall	20.3" (516.4 mm)
Flow, Min. at 2" H ₂ O (0.5 kPa) Restriction	450.0 CFM (12.7 m ³ /min)
Flow, Max. at 12" H ₂ O (3.0 kPa) Restriction	1225 CFM (34.7 m ³ /min)
Secondary Element	Yes
Housing Material	Glass-Filled Polyamide
Pre-Cleaner	No
Inlet	Straight 7.0" (177.8 mm)
Outlet	Straight 7.0" (177.8 mm)
Filter Efficiency	≥ 99.90% per ISO 5011

Specifications subject to change without notice.

Dust Holding Capacity per Flow Rate

Specification	Non Aspirated	
	CFM	m ³ /min
Maximum Flow for 10 g/CFM (3500 g/m ³ /min)	520	14.7
Maximum Flow for 25 g/CFM (8750 g/m ³ /min)	N/A	N/A

Dimensions

* Indicates maximum recommended flow rate

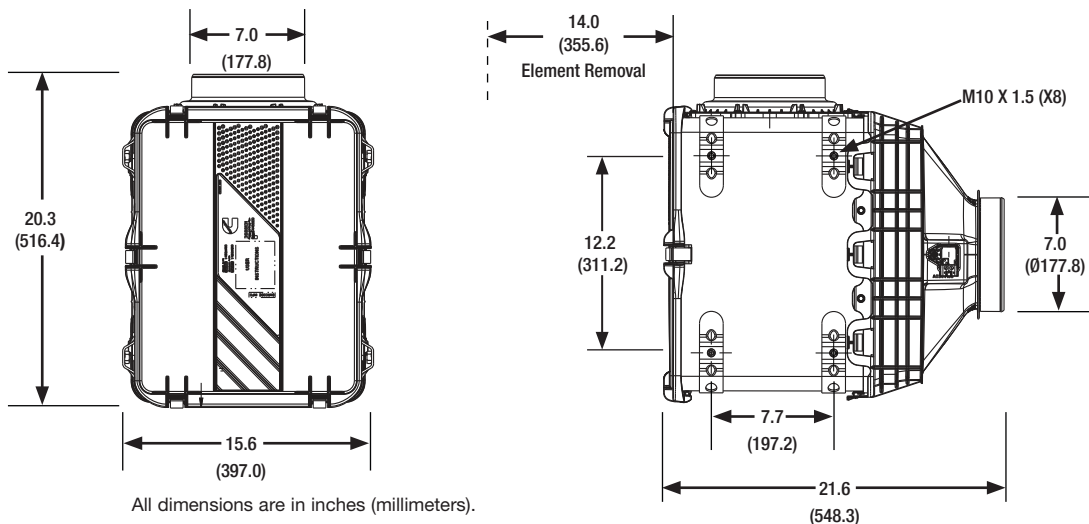

Ordering Information

Air Cleaners	
Part Number	Description
AH55589	Direct Flow - Short Side Inlet - With TBAP Sensor
AH55673	Direct Flow - Short Side Inlet - Without TBAP Sensor

TBAP -Temperature and Barometric Air Pressure

Service Parts	
Part Number	Description
AF55014	Primary Element (2 REQ)
AF55308	Secondary Element (2 REQ)
SP1013	Service Cover
SP1187	Service Cover Latches
SP1048	Dust Ejection Valve (DEV)

Optional Accessories	
Part Number	Description
3316663S	7" Band Clamp
3316613S	7" Hump Hose
3316586S	7" 45° Elbow
3316576S	7" 90° Elbow
3316624S	7" to 6" Hump Hose Reducer
3316593S	7" to 5.5" 90° Reducing Elbow
3316591S	7" to 5" 90° Reducing Elbow
3946329S	Restriction Indicator

Additional sizes/shapes may be available. Refer to the Cummins Filtration catalog or website.

Performance

System Restriction vs Flow Rate

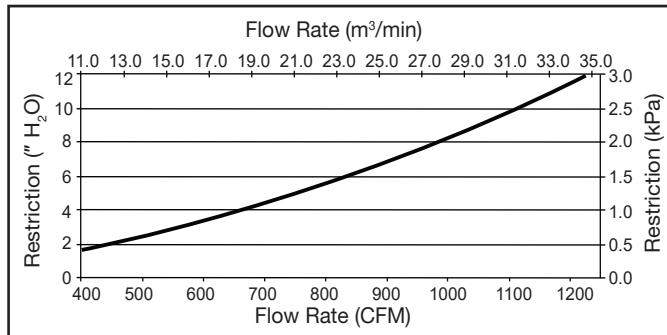

System Capacity vs Flow Rate

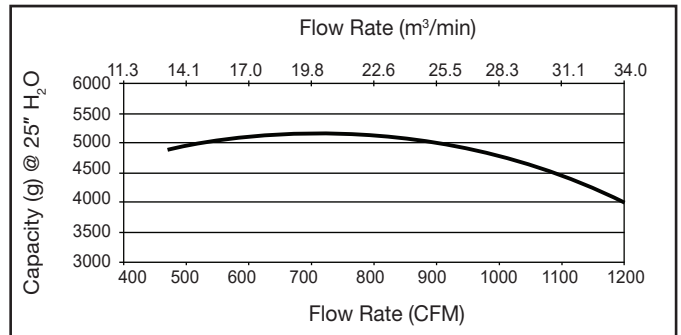

Restriction		Flow Rate		Typical Capacity at 25" H ₂ O (6.2 kPa) of Terminal Restriction
in H ₂ O	kPa	CFM	m³/min	Non Aspirated (g)
4	1.0	660	18.7	5200
6	1.5	840	23.8	5100
8	2.0	980	27.8	4900
10	2.5	1110	31.4	4400
12	3.0	1225	34.7	3900

ISO Fine Dust
1.0 g/m³ Feed Rate
25" H₂O (6.2 kPa)
Terminal Restriction
per ISO 5011

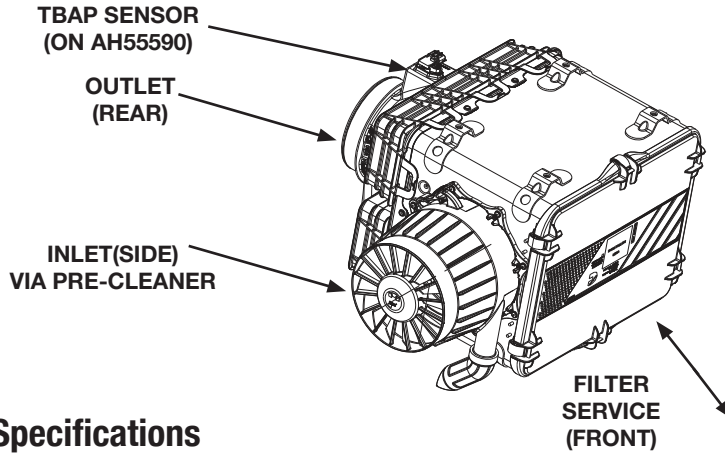

Specifications

Specification	AH55590 - AH55672
Length, Overall	21.6" (548.3 mm)
Width, Overall	26.1" (663.4 mm)
Height, Overall	15.6" (397.0 mm)
Flow, Min. at 2" H ₂ O (0.5 kPa) Restriction	340 CFM (9.6 m ³ /min)
Flow, Max. at 12" H ₂ O (3.0 kPa) Restriction	950 CFM (26.9 m ³ /min)
Secondary Element	Yes
Housing Material	Glass-Filled Polyamide
Pre-Cleaner	Yes
Inlet	Via Pre-Cleaner, 8" (203.0 mm)
Outlet	Straight, 7.0" (177.8 mm)
Filter Efficiency	≥ 99.90% per ISO 5011

Specifications subject to change without notice.

Dust Holding Capacity per Flow Rate

Specification	Aspirated		Non Aspirated	
	CFM	m ³ /min	CFM	m ³ /min
Maximum Flow for 10 g/CFM (3500 g/m ³ /min)	950*	26.9*	950*	26.9*
Maximum Flow for 25 g/CFM (8750 g/m ³ /min)	925	26.2	825	23.4

* Indicates maximum recommended flow rate .

Dimensions

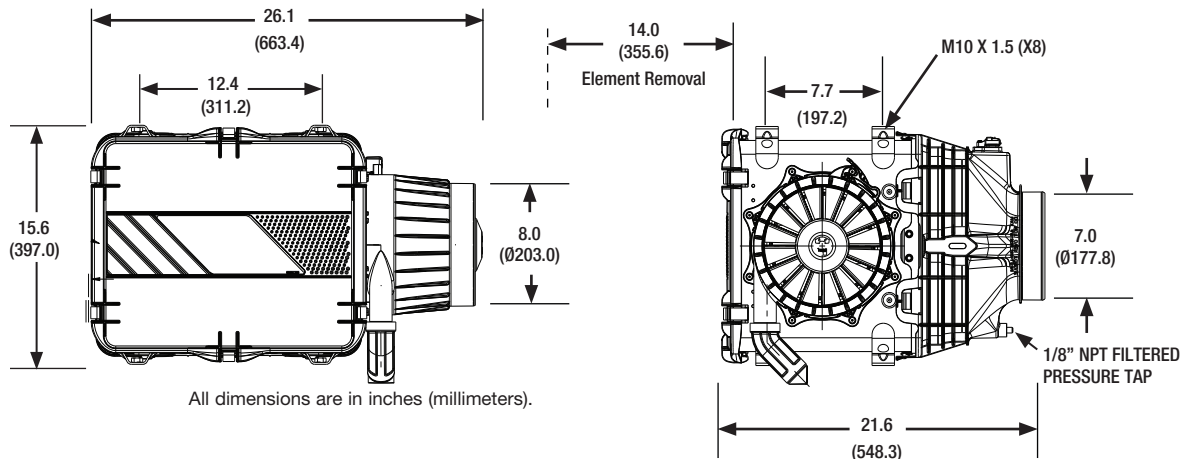

Ordering Information

Air Cleaners	
Part Number	Description
AH55590	Direct Flow - Integrated Pre-Cleaner - Short Side Inlet - With TBAP Sensor
AH55672	Direct Flow - Integrated Pre-Cleaner - Short Side Inlet - Without TBAP Sensor

TBAP -Temperature and Barometric Air Pressure

Service Parts	
Part Number	Description
AF55014	Primary Element (2 REQ)
AF55308	Secondary Element (2 REQ)
SP1013	Service Cover
SP1014	Pre-Cleaner with DEV
SP1048	Dust Ejection Valve (DEV)
SP1187	Service Cover Latches

Optional Accessories	
Part Number	Description
3316663S	7" Band Clamp
3316613S	7" Hump Hose
3316586S	7" 45° Elbow
3316576S	7" 90° Elbow
3316624S	7" to 6" Hump Hose Reducer
3316593S	7" to 5.5" 90° Reducing Elbow
3316591S	7" to 5" 90° Reducing Elbow
3946329S	Restriction Indicator

Additional sizes/shapes may be available.
Refer to the Cummins Filtration catalog or website.

Performance

System Restriction vs Flow Rate

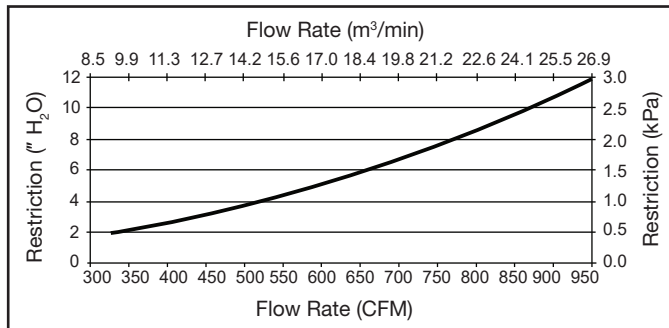

System Capacity vs Flow Rate

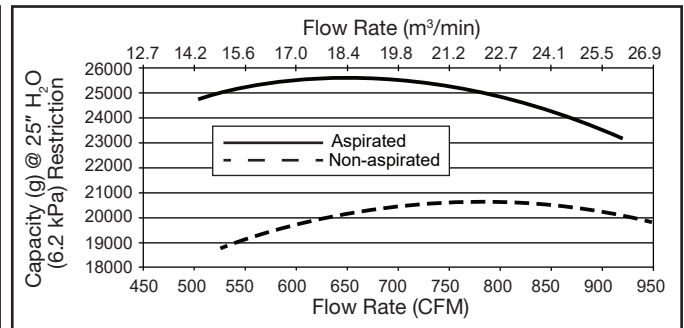

Restriction		Flow Rate		Typical Capacity at 25" H ₂ O (6.2 kPa) of Terminal Restriction	
in H ₂ O	kPa	CFM	m³/min	Aspirated (g)	Non Aspirated (g)
4	1.0	575	16.3	25000	18900
6	1.5	660	18.7	25800	20100
8	2.0	770	21.8	25100	20700
10	2.5	870	24.6	23900	20500
12	3.0	950	26.9	22500	19900

ISO Coarse Dust
2.0 g/m³ Feed Rate
25" H₂O (6.2 kPa)
Terminal Restriction
per ISO 5011

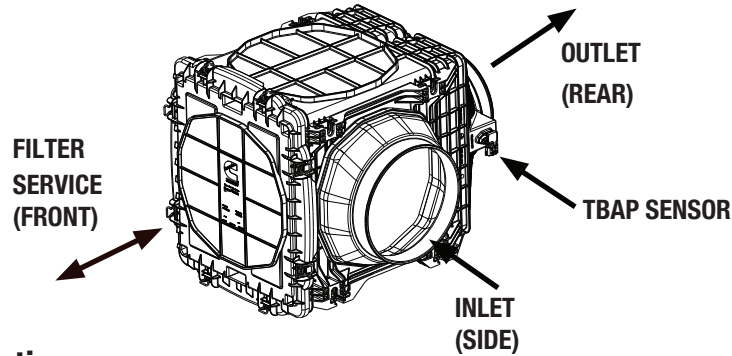

Specifications

Specification	AH55661
Length, Overall	24.4" (620.7 mm)
Width, Overall	19.5" (496.0 mm)
Height, Overall	13.9" (511.0 mm)
Flow, Min. at 2" H ₂ O (0.5 kPa) Restriction	597 CFM (16.9 m ³ /min)
Flow, Max. at 12" H ₂ O (3.0 kPa) Restriction	1609 CFM (45.5 m ³ /min)
Secondary Element	Yes
Housing Material	Glass-Filled Polypropylene
Pre-Cleaner	No
Inlet	90° to Outlet, 10.0" (254.0 mm)
Outlet	Straight, 8.0" (203.2 mm)
Filter Efficiency	≥ 99.90% per ISO 5011

Specifications subject to change without notice.

Dust Holding Capacity per Flow Rate

Specification	Non Aspirated	
	CFM	m ³ /min
Maximum Flow for 10 g/CFM (357.1 g/m ³ /min)	525	14.8
Maximum Flow for 25 g/CFM (892.9 g/m ³ /min)	N/A*	N/A*

*Requires precleaner (optional)

Dimensions

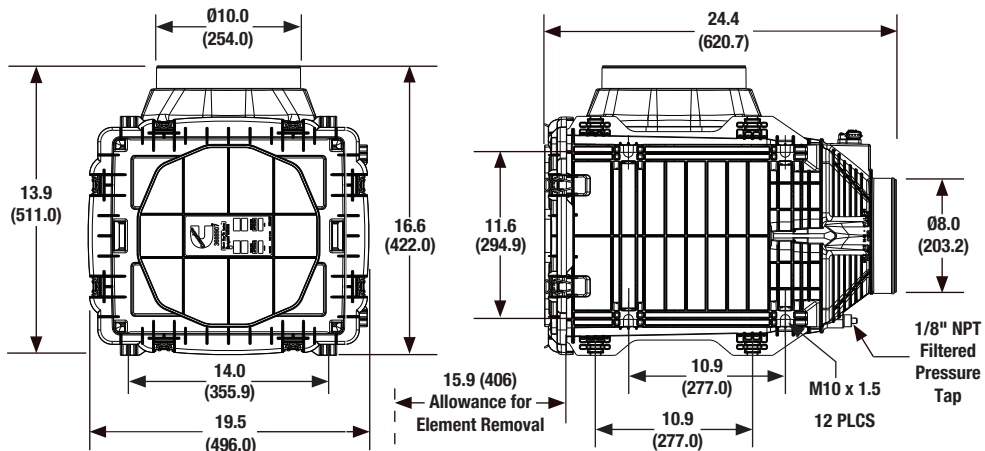

All dimensions are in inches (millimeters)

Ordering Information

Air Cleaners	
Part Number	Description
AH55661	Direct Flow - Side Inlet - With TBAP Sensor

TBAP -Temperature and Barometric Air Pressure

Service Parts	
Part Number	Description
AF55024	Primary Element (2 REQ)
AF55318	Secondary Element (2 REQ)
SP1082	Service Cover
SP1085	M10 Mounting Hardware
SP1090	Service Cover Gasket
SP1308	Mounting Stand-Offs
SP1086	Dust Ejection Valve (DEV)

Optional Accessories	
Part Number	Description
3316664S	8" Band Clamp
3316614S	8" Hump Hose
3316587S	8" 45° Elbow
3316577S	8" 90° Elbow
3316626S	8"-7" Hump Hose Reducer
3946329S	Restriction Indicator

Additional sizes/shapes may be available. Refer to the Cummins Filtration catalog or website.

Performance

System Restriction vs Flow Rate

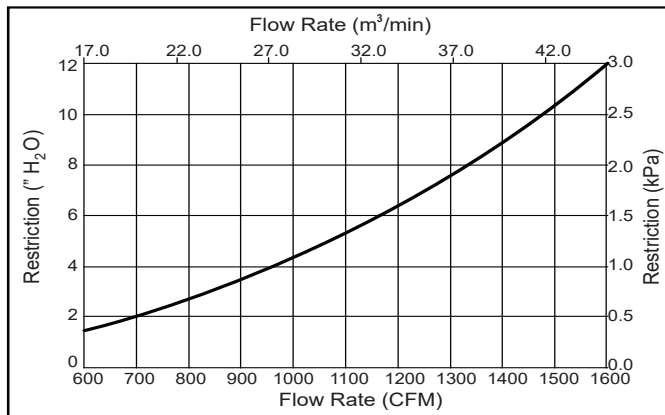

System Capacity vs Flow Rate

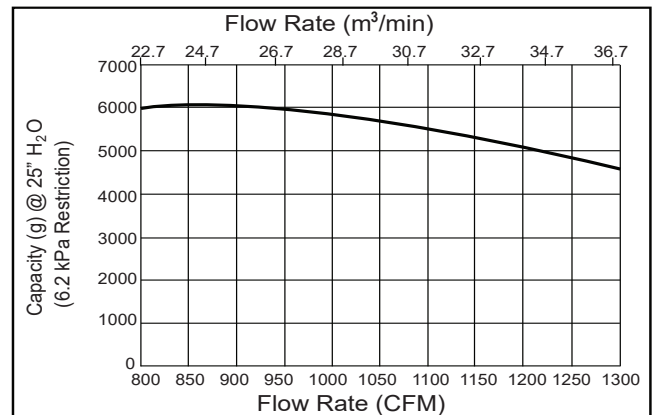

Restriction		Flow Rate		Typical Capacity at 25" H ₂ O (6.2 kPa) of Terminal Restriction
in H ₂ O	kPa	CFM	m³/min	Non Aspirated (g)
4	1.0	893	25.3	6062
6	1.5	1114	31.6	5575
8	2.0	1300	36.8	4601
10	2.5	1462	41.4	3333
12	3.0	1609	45.6	1843

ISO Fine Dust
1.0 g/m³ Feed Rate
25" H₂O (6.2 kPa)
Terminal Restriction
per ISO 5011

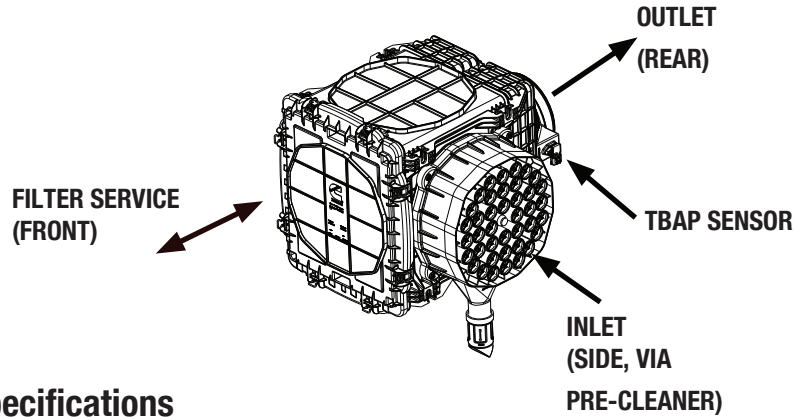

Specifications

Specification	AH55662
Length, Overall	24.4" (620.7 mm)
Width, Overall	21.3" (542.0 mm)
Height, Overall	25.0" (636.4 mm)
Flow, Min. at 2" H ₂ O (0.5 kPa) Restriction	473 CFM (13.39 m ³ /min)
Flow, Max. at 12" H ₂ O (3.0 kPa) Restriction	1211 CFM (34.3 m ³ /min)
Secondary Element	Yes
Housing Material	Glass-Filled Polypropylene
Pre-Cleaner	Integrated
Inlet	90° to outlet 12.5" (317.9 mm)
Outlet	Straight, 8.0" (203.2 mm)
Filter Efficiency	≥ 99.90% per ISO 5011

Specifications subject to change without notice.

Dust Holding Capacity per Flow Rate

Specification	Aspirated		Non Aspirated	
	CFM	m ³ /min	CFM	m ³ /min
Maximum Flow for 10 g/CFM (357.1 g/m ³ /min)	1211*	34.3*	1211*	34.3*
Maximum Flow for 25 g/CFM (892.9 g/m ³ /min)	790	22.4	1211*	34.3*

*Indicates maximum recommended flow rate

Dimensions

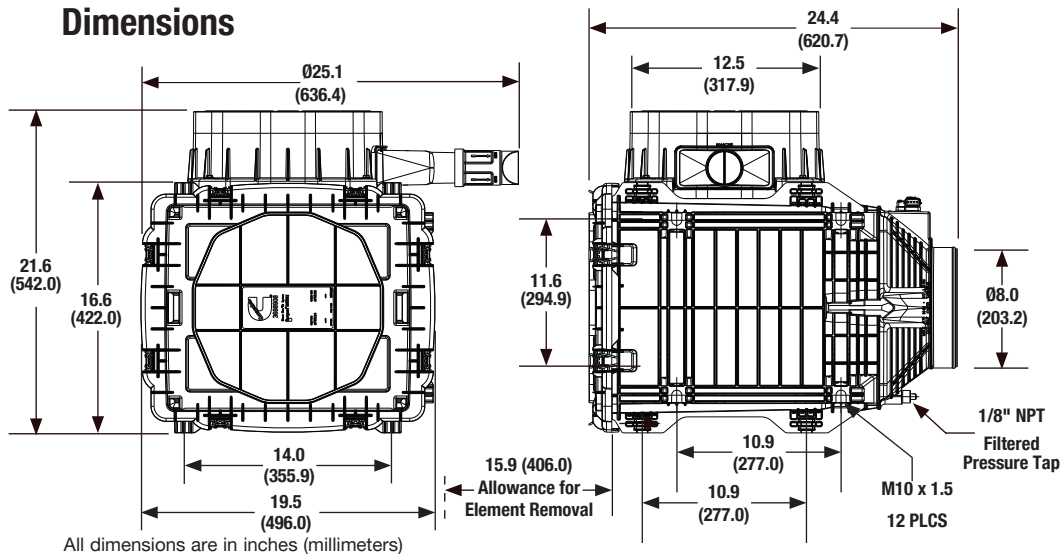

Ordering Information

Air Cleaners	
Part Number	Description
AH55662	Direct Flow - Side Inlet - Pre-Cleaner - With TBAP Sensor

TBAP -Temperature and Barometric Air Pressure

Service Parts	
Part Number	Description
AF55024	Primary Element (2 REQ)
AF55318	Secondary Element (2 REQ)
SP1082	Service Cover
SP1085	M10 Mounting Hardware
SP1090	Service Cover Gasket
SP1308	Mounting Stand-Offs
SP1086	Dust Ejection Valve (DEV)

Optional Accessories	
Part Number	Description
3316664S	8" Band Clamp
3316614S	8" Hump Hose
3316662S	6" Band Clamp
3316587S	8" 45° Elbow
3316577S	8" 90° Elbow
3316626S	8" to 7" Hump Hose Reducer
3946329S	Restriction Indicator

Additional sizes/shapes may be available. Refer to the Cummins Filtration catalog or website.

Performance

System Restriction vs Flow Rate

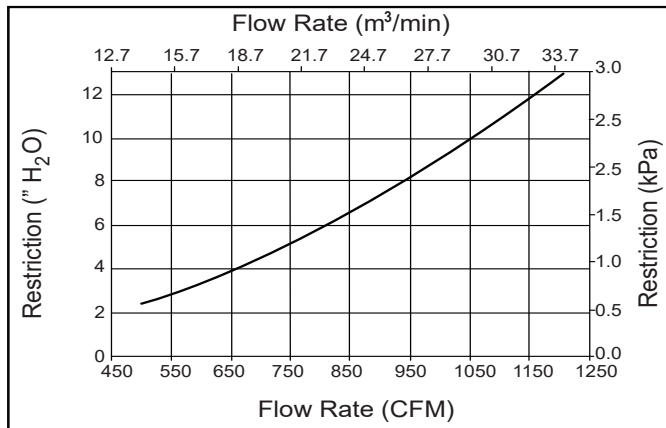

System Capacity vs Flow Rate

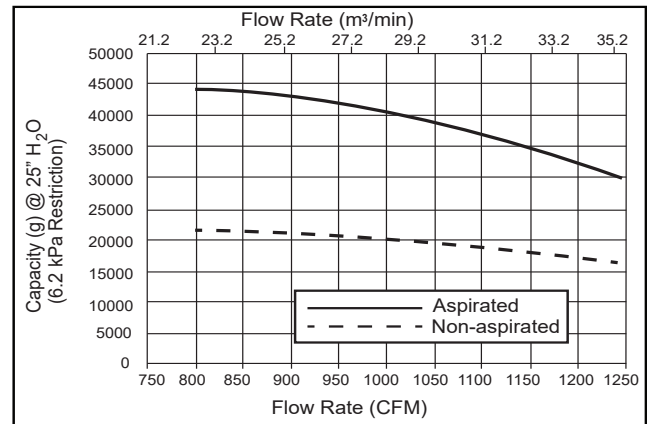

Restriction		Flow Rate		Typical Capacity at 25" H ₂ O (6.2 kPa) of Terminal Restriction	
in H ₂ O	kPa	CFM	m³/min	Aspirated (g)	Non Aspirated (g)
4	1.0	683	19.3	16256	44106
6	1.5	845	23.9	20382	43854
8	2.0	981	27.8	22166	41366
10	2.5	1102	31.2	21429	37405
12	3.0	1211	34.3	19214	32428

ISO Coarse Dust
2.0 g/m³ Feed Rate
25" H₂O (6.2 kPa)
Terminal Restriction
per ISO 5011

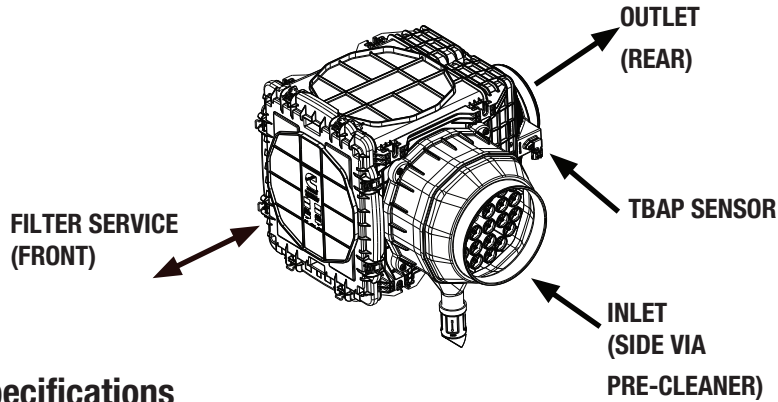

Specifications

Specification	AH55663
Length, Overall	24.4" (620.7 mm)
Width, Overall	25.6" (652.0 mm)
Height, Overall	25.0" (636.4 mm)
Flow, Min. at 2" H ₂ O (0.5 kPa) Restriction	470 CFM (13.3 m ³ /min)
Flow, Max. at 12" H ₂ O (3.0 kPa) Restriction	1208 CFM (34.2 m ³ /min)
Secondary Element	Yes
Housing Material	Glass-Filled Polypropylene
Pre-Cleaner	Integrated
Inlet	90° to Outlet, 10.0" (254.0 mm)
Outlet	Straight, 8.0" (203.2 mm)
Filter Efficiency	≥ 99.90% per ISO 5011

Specifications subject to change without notice.

Dust Holding Capacity per Flow Rate

Specification	Aspirated		Non Aspirated	
	CFM	m ³ /min	CFM	m ³ /min
Maximum Flow for 10 g/CFM (357.1 g/m ³ /min)	1208*	34.2*	1208*	34.2*
Maximum Flow for 25 g/CFM (892.9 g/m ³ /min)	887	25.1	1208*	34.2*

*Indicates maximum recommended flow rate

Dimensions

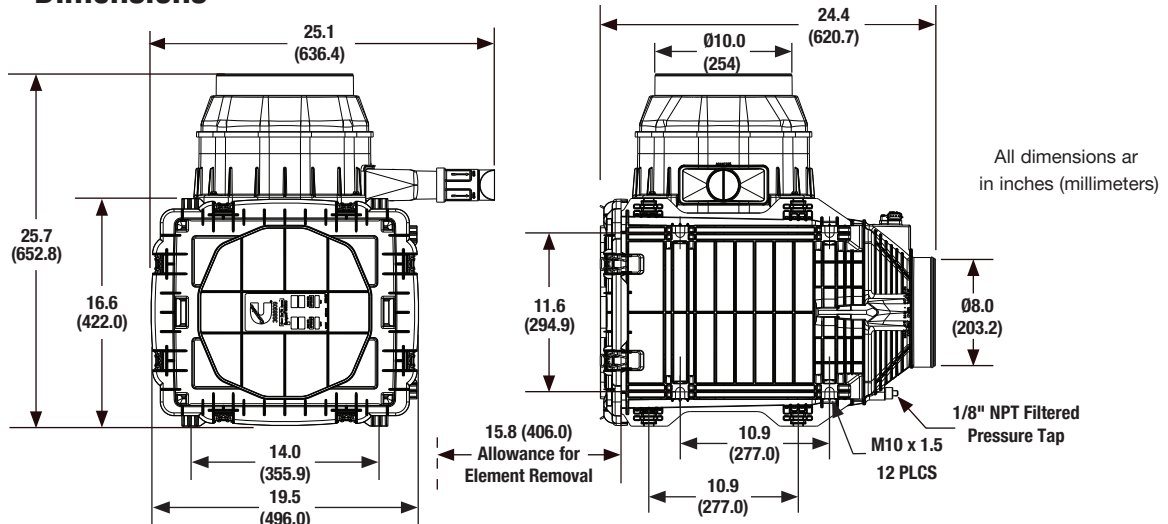

All dimensions are in inches (millimeters)

Ordering Information

Air Cleaners	
Part Number	Description
AH55663	Direct Flow - Side Inlet - Integrated Pre-Cleaner - With TBAP Sensor

TBAP -Temperature and Barometric Air Pressure

Service Parts	
Part Number	Description
AF55024	Primary Element (2 REQ)
AF55318	Secondary Element (2 REQ)
SP1082	Service Cover
SP1085	M10 Mounting Hardware
SP1090	Service Cover Gasket
SP1308	Mounting Stand-Offs
SP1086	Dust Ejection Valve (DEV)

Optional Accessories	
Part Number	Description
3316664S	8" Band Clamp
3316614S	8" Hump Hose
3316587S	8" 45° Elbow
3316577S	8" 90° Elbow
3316626S	8" to 7" Hump Hose Reducer
3946329S	Restriction Indicator

Additional sizes/shapes may be available. Refer to the Cummins Filtration catalog or website.

Performance

System Restriction vs Flow Rate

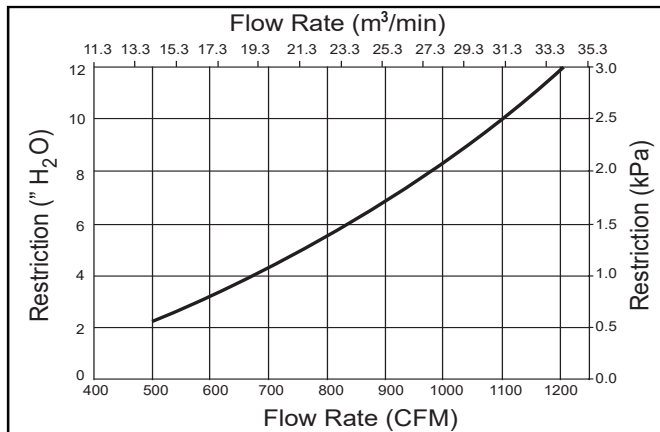

System Capacity vs Flow Rate

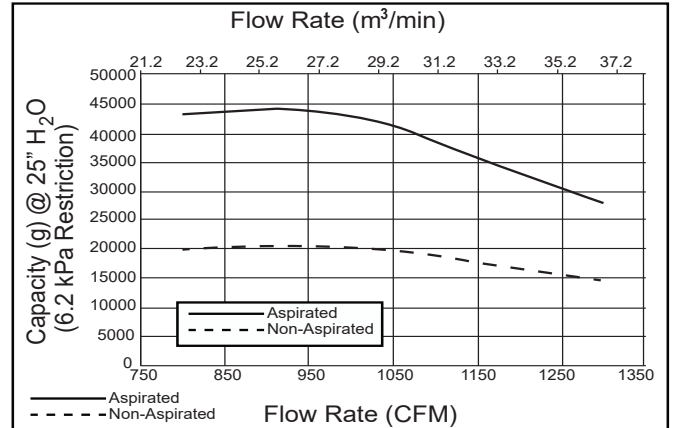

Restriction		Flow Rate		Typical Capacity at 25" H ₂ O (6.2 kPa) of Terminal Restriction	
" H ₂ O	kPa	CFM	m³/min	Aspirated (g)	Non Aspirated (g)
4	1.0	679	19.2	20429	40087
6	1.5	841	23.8	22147	43462
8	2.0	978	27.7	21793	43133
10	2.5	1098	31.1	20123	40449
12	3.0	1208	34.2	17476	36022

ISO Coarse Dust
2.0 g/m³ Feed Rate
25" H₂O (6.2 kPa)
Terminal Restriction
per ISO 5011

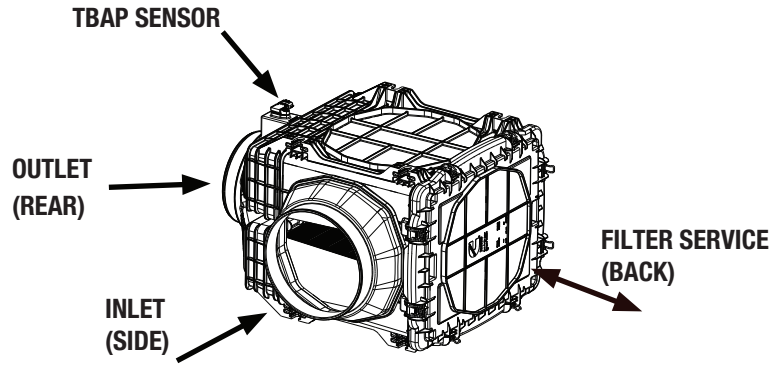

Specifications

Specification	AH55664
Length, Overall	24.4" (620.7 mm)
Width, Overall	22.6" (574.6 mm)
Height, Overall	16.6" (422.0 mm)
Flow, Min. at 2" H ₂ O (0.5 kPa) Restriction	622 CFM (17.6 m ³ /min)
Flow, Max. at 12" H ₂ O (3.0 kPa) Restriction	1643 CFM (46.5 m ³ /min)
Secondary Element	Yes
Housing Material	Glass-Filled Polypropylene
Pre-Cleaner	No
Inlet	90° to Outlet, 10.0" (254.0 mm)
Outlet	Straight, 8.0" (203.2 mm)
Filter Efficiency	≥ 99.90% per ISO 5011

Specifications subject to change without notice.

Dust Holding Capacity per Flow Rate

Specification	Non Aspirated	
	CFM	m ³ /min
Maximum Flow for 10 g/CFM (357.1 g/m ³ /min)	605	17.1
Maximum Flow for 25 g/CFM (892.9 g/m ³ /min)	N/A*	N/A*

*Requires precleaner (optional)

Dimensions

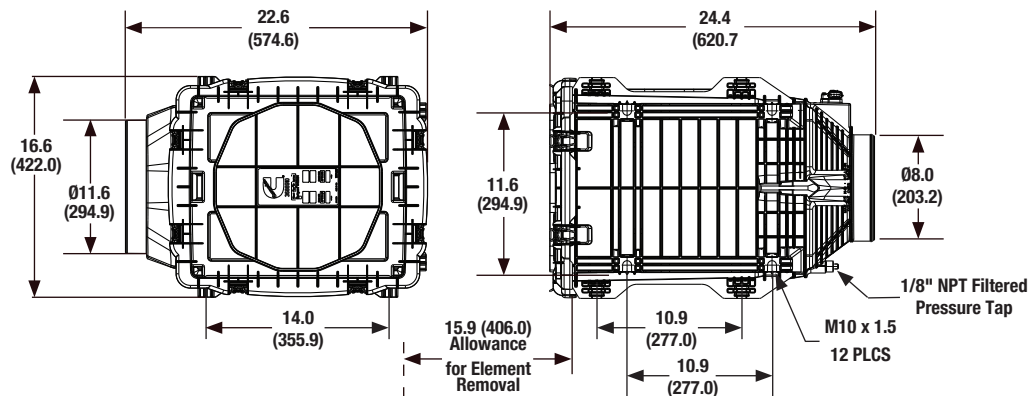

All dimensions are in inches (millimeters)

Ordering Information

Air Cleaners	
Part Number	Description
AH55664	Direct Flow - Side Inlet - With TBAP Sensor

TBAP -Temperature and Barometric Air Pressure

Service Parts	
Part Number	Description
AF55024	Primary Element (2 REQ)
AF55318	Secondary Element 2 REQ)
SP1082	Service Cover
SP1185	M10 Mounting Hardware
SP1090	Service Cover Gasket
SP1308	Mounting Stand-Offs
SP1086	Dust Ejection Valve (DEV)

Optional Accessories	
Part Number	Description
3316664S	8" Band Clamp
3316614S	8" Hump Hose
3316587S	8" 45° Elbow
3316577S	8" 90° Elbow
3316626S	8" to 7" Hump Hose Reducer
3946329S	Restriction Indicator

Additional sizes/shapes may be available. Refer to the Cummins Filtration catalog or website.

Performance

System Restriction vs Flow Rate

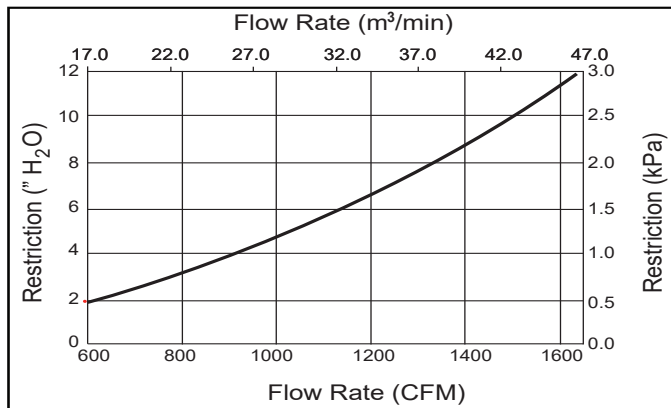

System Capacity vs Flow Rate

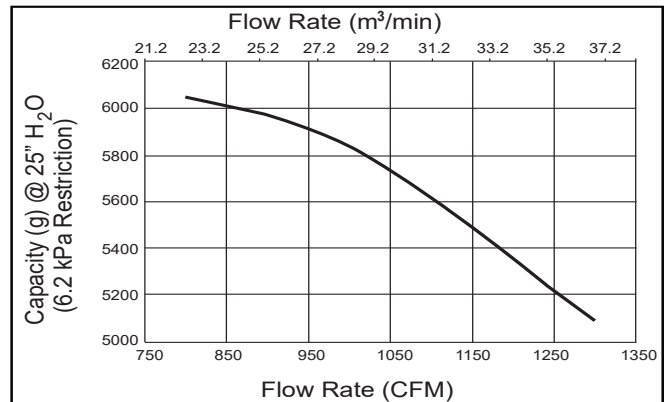

Restriction		Flow Rate		Typical Capacity at 25" H ₂ O (6.2 kPa) of Terminal Restriction
in H ₂ O	kPa	CFM	m³/min	Non-Aspirated (g)
4	1.0	918	26.0	5954
6	1.5	1141	32.3	5552
8	2.0	1329	37.6	4987
10	2.5	1494	42.3	4321
12	3.0	1643	46.5	3584

ISO Fine Dust
1.0 g/m³ Feed Rate
25" H₂O (6.2 kPa)
Terminal Restriction
per ISO 5011

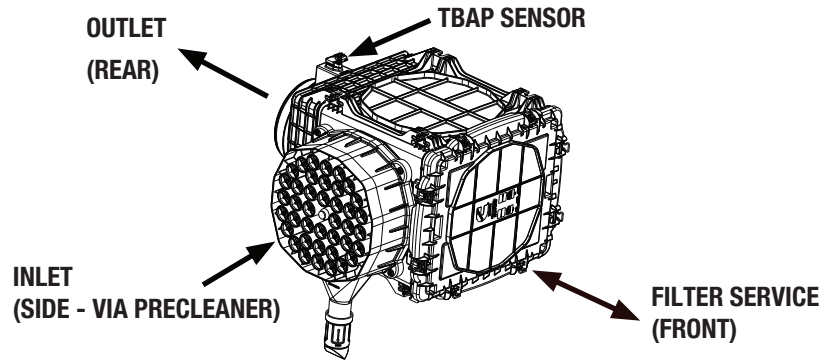

Specifications

Specification	AH55665
Length, Overall	24.4" (620.7 mm)
Width, Overall	22.6" (574.6 mm)
Height, Overall	16.6" (422.0 mm)
Flow, Min. at 2" H ₂ O (0.5 kPa) Restriction	470 CFM (13.31 m ³ /min)
Flow, Max. at 12" H ₂ O (3.0 kPa) Restriction	1212 CFM (34.32 m ³ /min)
Secondary Element	Yes
Housing Material	Glass-Filled Polypropylene
Pre-Cleaner	Integrated
Inlet	90° to Outlet, 12.5" (317.5 mm)
Outlet	Straight, 8.0" (203.2 mm)
Filter Efficiency	≥ 99.90% per ISO 5011

Specifications subject to change without notice.

Dust Holding Capacity per Flow Rate

Specification	Non Aspirated		Aspirated	
	CFM	m ³ /min	CFM	m ³ /min
Maximum Flow for 10 g/CFM (357.1 g/m ³ /min)	1212*	34.3*	1212*	34.3*
Maximum Flow for 25 g/CFM (892.9 g/m ³ /min)	887	25.1	1212*	34.3*

*Indicates maximum recommended flow rate

Dimensions

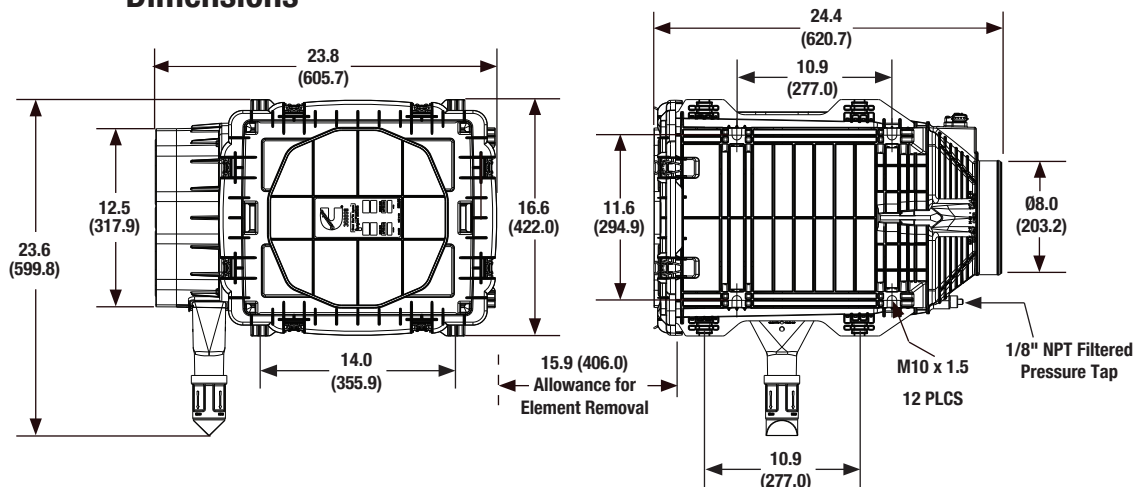

All dimensions are in inches (millimeters)

Ordering Information

Air Cleaners	
Part Number	Description
AH55665	Direct Flow - Side Inlet - Integrated Pre-Cleaner - With TBAP Sensor

TBAP -Temperature and Barometric Air Pressure

Service Parts	
Part Number	Description
AF55024	Primary Element (2 REQ)
AF55318	Secondary Element (2 REQ)
SP1082	Service Cover
SP1085	M10 Mounting Hardware
SP1090	Service Cover Gasket
SP1308	Mounting Stand-Offs
SP1086	Dust Ejection Valve (DEV)

Optional Accessories	
Part Number	Description
3316664S	8" Band Clamp
3316614S	8" Hump Hose
3316587S	8" 45° Elbow
3316577S	8" 90° Elbow
3316626S	8" to 7" Hump Hose Reducer
3946329S	Restriction Indicator

Additional sizes/shapes may be available. Refer to the Cummins Filtration catalog or website.

Performance

System Restriction vs Flow Rate

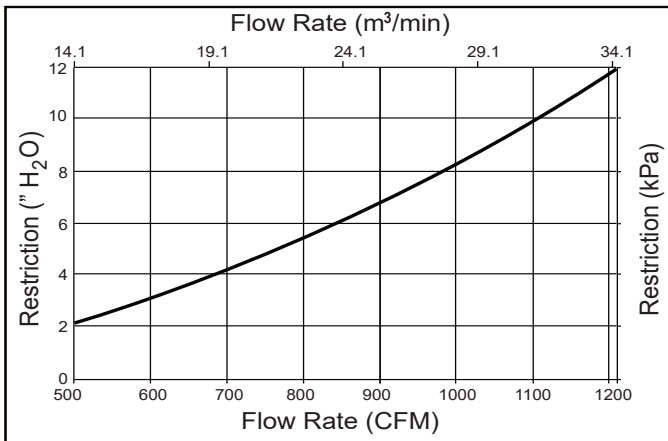

System Capacity vs Flow Rate

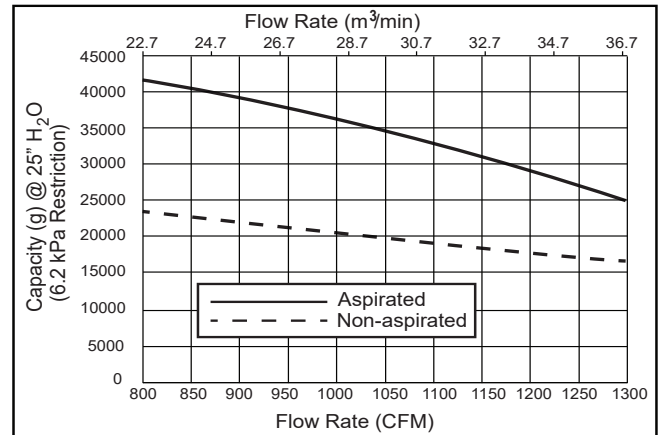

Restriction		Flow Rate		Typical Capacity at 25" H ₂ O (6.2 kPa) of Terminal Restriction	
in H ₂ O	kPa	CFM	m ³ /min	Non-Aspirated (g)	Aspirated (g)
4	1.0	683	19.3	25770	43718
6	1.5	845	23.9	22902	40679
8	2.0	982	27.8	20745	37064
10	2.5	1103	31.2	19045	33075
12	3.0	1212	34.3	17679	28842

ISO Coarse Dust
2.0 g/m³ Feed Rate
25" H₂O (6.2 kPa)
Terminal Restriction
per ISO 5011

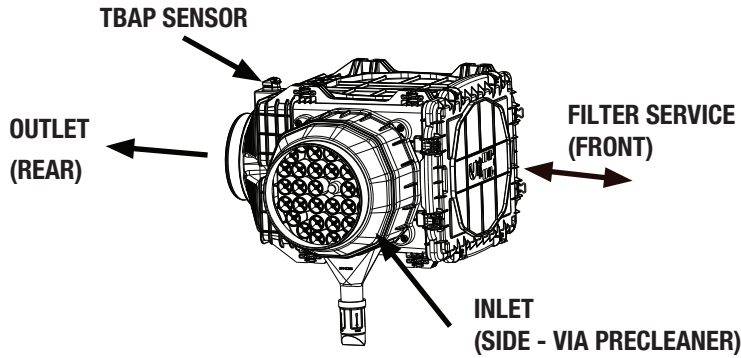

Specifications

Specification	AH55666
Length, Overall	24.4" (620.7 mm)
Width, Overall	28.2" (716.5 mm)
Height, Overall	23.6" (599.8 mm)
Flow, Min. at 2" H ₂ O (0.5 kPa) Restriction	473 CFM (13.4 m ³ /min)
Flow, Max. at 12" H ₂ O (3.0 kPa) Restriction	1230 CFM (34.8 m ³ /min)
Secondary Element	Yes
Housing Material	Glass-Filled Polypropylene
Pre-Cleaner	Integrated
Inlet	90° to Outlet, 10.0" (254.0 mm)
Outlet	Straight, 8.0" (203.2 mm)
Filter Efficiency	≥ 99.90% per ISO 5011

Specifications subject to change without notice.

Dust Holding Capacity per Flow Rate

Specification	Non Aspirated		Aspirated	
	CFM	m ³ /min	CFM	m ³ /min
Maximum Flow for 10 g/CFM (357.1 g/m ³ /min)	1230*	34.8*	1230*	34.8*
Maximum Flow for 25 g/CFM (892.9 g/m ³ /min)	981	27.8	1230*	34.8*

*Indicates maximum recommended flow rate

Dimensions

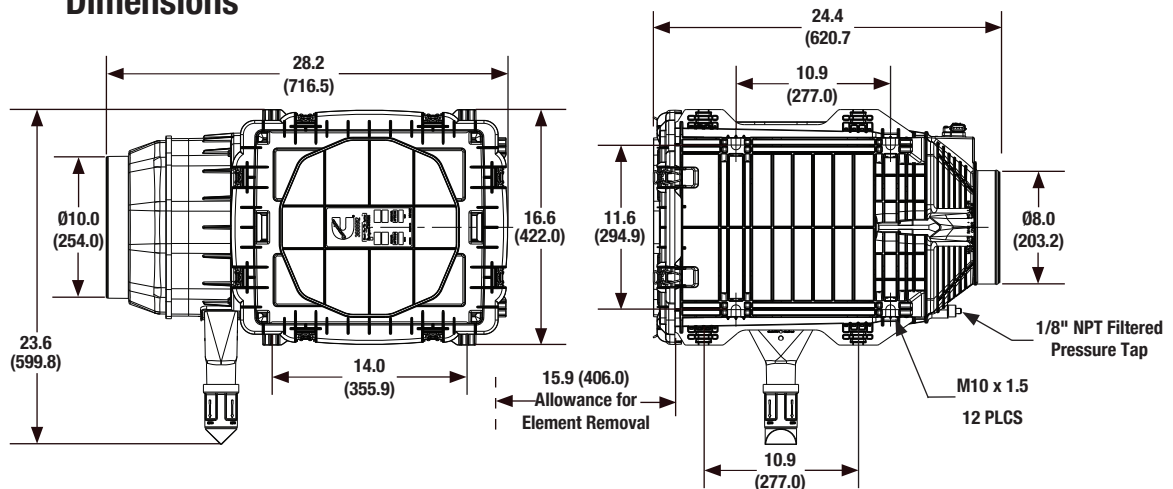

All dimensions are in inches (millimeters)

Ordering Information

Air Cleaners	
Part Number	Description
AH55666	Direct Flow - Front Inlet - Integrated Pre-Cleaner - With TBAP Sensor

TBAP -Temperature and Barometric Air Pressure

Service Parts	
Part Number	Description
AF55024	Primary Element (2 REQ)
AF55318	Secondary Element (2 REQ)
SP1082	Service Cover
SP1085	M10 Mounting Hardware
SP1090	Service Cover Gasket
SP1308	Mounting Stand-Offs
SP1086	Dust Ejection Valve (DEV)

Optional Accessories	
Part Number	Description
3316664S	8" Band Clamp
3316614S	8" Hump Hose
3316587S	8" 45° Elbow
3316577S	8" 90° Elbow
3316626S	8" to 7" Hump Hose Reducer
3946329S	Restriction Indicator

Additional sizes/shapes may be available. Refer to the Cummins Filtration catalog or website.

Performance

System Restriction vs Flow Rate

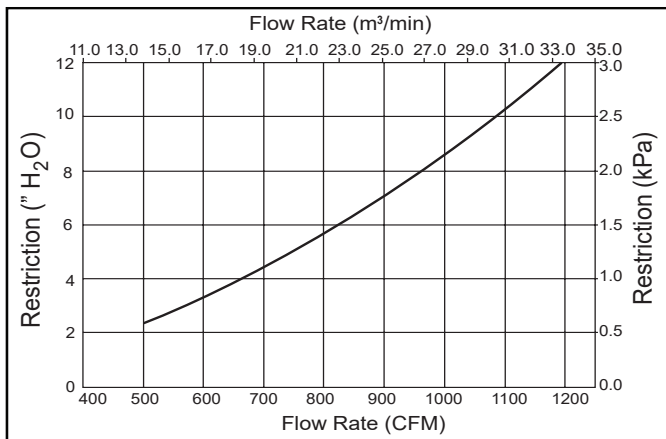

System Capacity vs Flow Rate

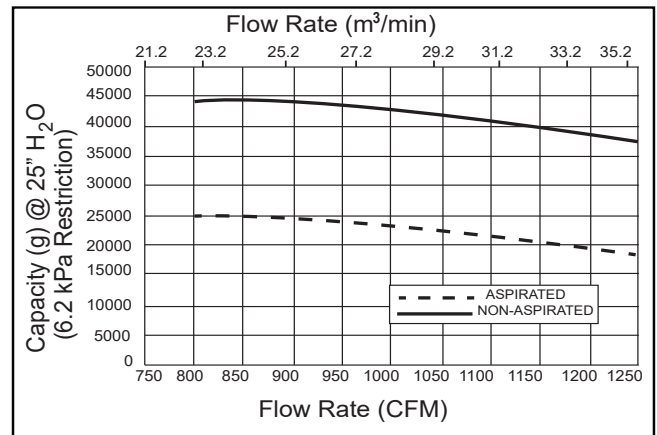

Restriction		Flow Rate		Typical Capacity at 25" H ₂ O (6.2 kPa) of Terminal Restriction	
in H ₂ O	kPa	CFM	m³/min	Non-Aspirated (g)	Aspirated (g)
4	1.0	683	19.3	27604	40940
6	1.5	849	24.0	26180	45548
8	2.0	990	28.0	24437	45500
10	2.5	1116	31.6	22465	42378
12	3.0	1230	34.8	20343	37049

ISO Coarse Dust
2.0 g/m³ Feed Rate
25" H₂O (6.2 kPa)
Terminal Restriction
per ISO 5011

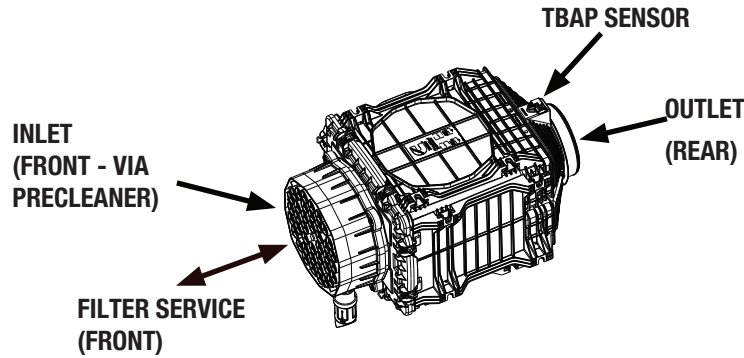

Specifications

Specification	AH55668
Length, Overall	24.4" (620.7 mm)
Width, Overall	22.6" (574.6 mm)
Height, Overall	25.0" (636.4 mm)
Flow, Min. at 2" H ₂ O (0.5 kPa) Restriction	474 CFM (13.4 m ³ /min)
Flow, Max. at 12" H ₂ O (3.0 kPa) Restriction	1280 CFM (36.2 m ³ /min)
Secondary Element	Yes
Housing Material	Glass-Filled Polypropylene
Pre-Cleaner	Integrated
Inlet	Straight 12.5" (317.5 mm)
Outlet	Straight, 8.0" (203.2 mm)
Filter Efficiency	≥ 99.90% per ISO 5011

Specifications subject to change without notice.

Dust Holding Capacity per Flow Rate

Specification	Non Aspirated		Aspirated	
	CFM	m ³ /min	CFM	m ³ /min
Maximum Flow for 10 g/CFM (357.1 g/m ³ /min)	1280*	36.2*	1280*	36.2*
Maximum Flow for 25 g/CFM (892.9 g/m ³ /min)	948	26.8	1280*	36.2*

*Indicates maximum recommended flow rate

Dimensions

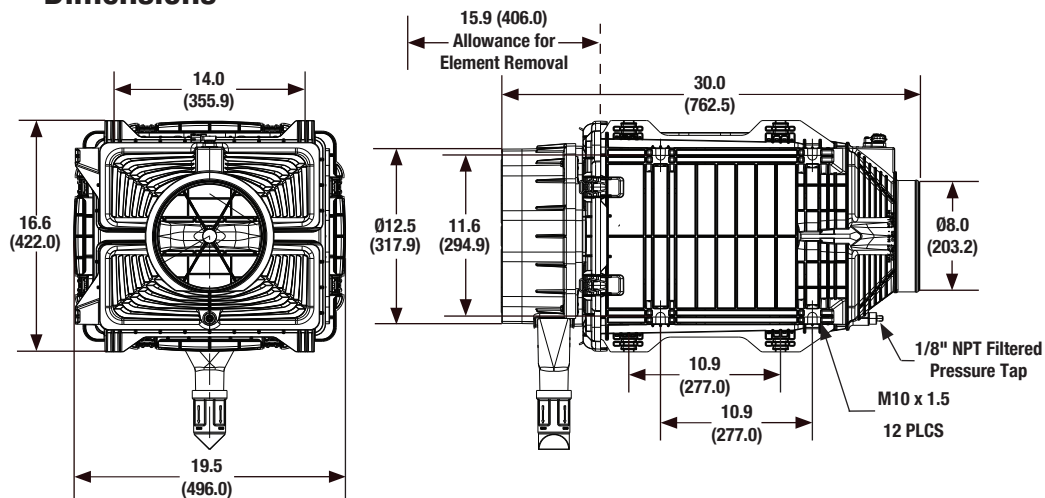

All dimensions are in inches (millimeters)

Ordering Information

Air Cleaners	
Part Number	Description
AH55668	Direct Flow - Front Inlet - Integrated Pre-Cleaner - With TBAP Sensor

TBAP -Temperature and Barometric Air Pressure

Service Parts	
Part Number	Description
AF55024	Primary Element (2 REQ)
AF55318	Secondary Element (2 REQ)
SP1084	Service Cover
SP1085	M10 Mounting Hardware
SP1090	Service Cover Gasket
SP1308	Mounting Stand-Offs
SP1086	Dust Ejection Valve (DEV)

Optional Accessories	
Part Number	Description
3316664S	8" Band Clamp
3316614S	8" Hump Hose
3316587S	8" 45° Elbow
3316577S	8" 90° Elbow
3316626S	8" to 7" Hump Hose Reducer
3946329S	Restriction Indicator

Additional sizes/shapes may be available. Refer to the Cummins Filtration catalog or website.

Performance

System Restriction vs Flow Rate

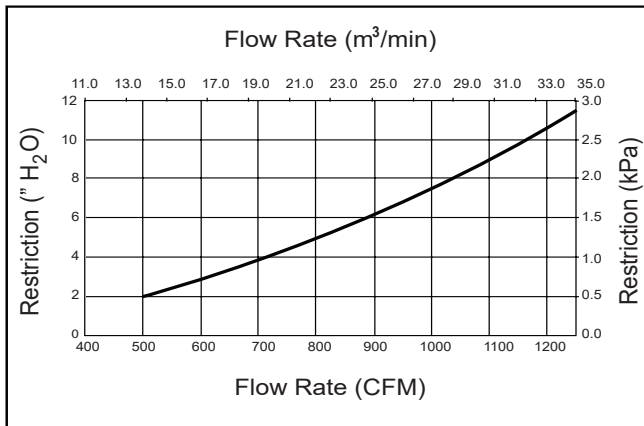

System Capacity vs Flow Rate

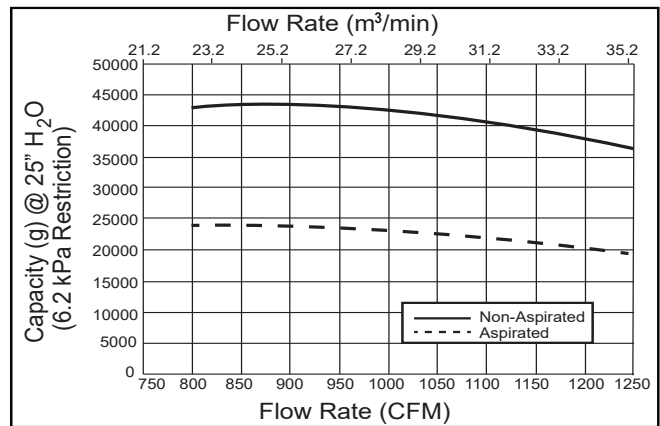

Restriction		Flow Rate		Typical Capacity at 25" H ₂ O (6.2 kPa) of Terminal Restriction	
in H ₂ O	kPa	CFM	m³/min	Non-Aspirated (g)	Aspirated (g)
4	1.0	737	20.9	24171	42534
6	1.5	904	25.6	23945	43418
8	2.0	1045	29.6	22809	42091
10	2.5	1168	33.1	21096	39364
12	3.0	1280	36.2	18965	35267

ISO Coarse Dust
2.0 g/m³ Feed Rate
25" H₂O (6.2 kPa)
Terminal Restriction
per ISO 5011

How to Service a Direct Flow™ System

Servicing the Direct Flow™ Air Cleaners

1. Open the metal latches to remove the service cover.

DF600 Element Size

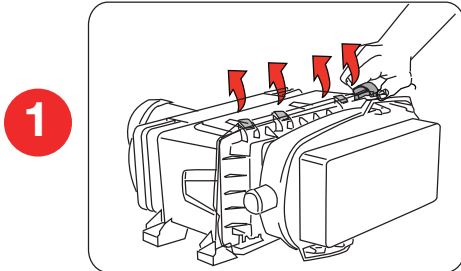

DF900 Element Size

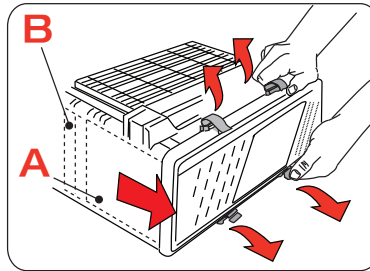

DF1200 Element Size

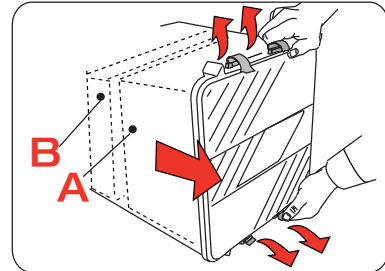

2. Remove the primary element. .

DF600 Element Size

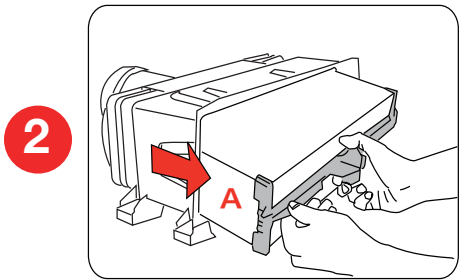

DF900 Element Size

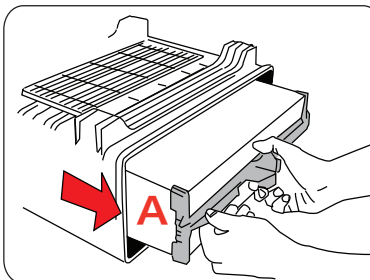

DF1200 Element Size

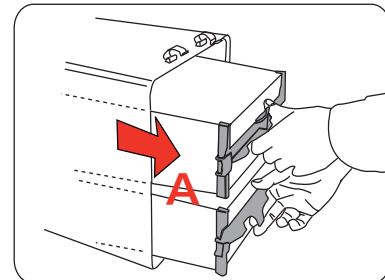

3. Remove the secondary element. .

DF600 Element Size

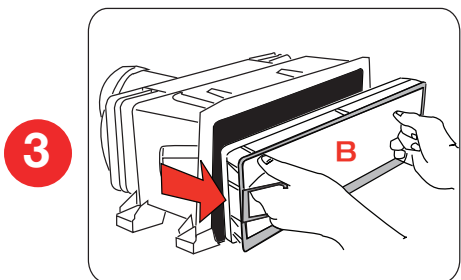

DF900 Element Size

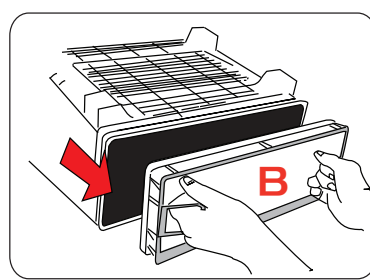

DF1200 Element Size

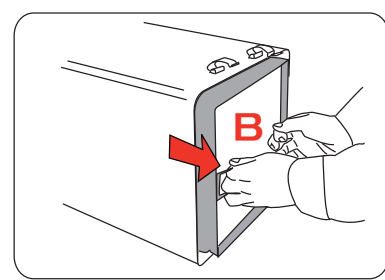

4. Replace the primary and secondary elements in the same order and close the metal latches. .

DF600 Element Size

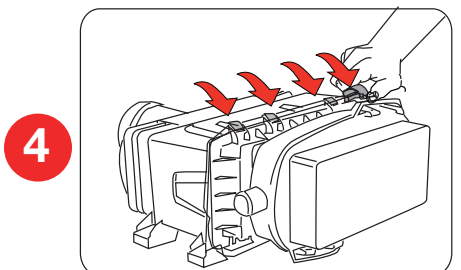

DF900 Element Size

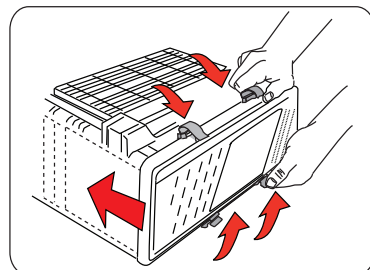

DF1200 Element Size

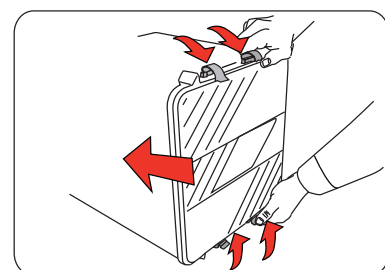

Direct Flow™ Frequently Asked Questions

Why are two types of Direct Flow™ models available?

The Cummins applied models are manufactured with a TBAP (Temperature Barometric Air Pressure) sensor that is tailored for specifics of a Cummins applied engine system. The standard models are manufactured for a broader range of systems.

How is Direct Flow™ different from a traditional cylindrical air cleaner?

The Direct Flow filter element utilizes a rectangular “V-Block” configuration which allows the filter media to be packaged in a smaller volume, improving performance while reducing size. The rectangular design allows the Direct Flow air cleaner to take advantage of the wasted space in the inner diameter of the conventional air cleaner. The benefits of Direct Flow system are an increase in total dust holding capacity and a decrease in size. These features allow for a longer service interval, less maintenance and vehicle down time, a lower cost of ownership, and the ability to mount the air cleaner in location previously unobtainable with a conventional air cleaner. The Direct Flow air cleaner also includes an integrated pre-cleaner and integrated mounting feet.

How long will it last?

The Direct Flow™ air cleaner has been designed to package the optimal amount of filter media in the smallest volume, increasing life and service interval. Compared to an equivalent traditional cylindrical air cleaner, the Direct Flow air cleaner will outperform and outlast conventional cylindrical air cleaners.

Where can I get replacement Elements?

Direct Flow aftermarket replacement filter elements and service parts will be available at hundreds of Cummins Filtration® and Fleetguard® worldwide retail locations. Visit cumminsfiltration.com for the nearest location.

How do I mount this air cleaner?

The Direct Flow air cleaners have integrated mounting feet on both the top and bottom sides of the housing which allow for easier and more convenient installations. Additional mounting band clamps are no longer required as compared to the conventional cylindrical air cleaners. The Direct Flow air cleaner can be mounted either vertically or horizontally.

What does the sensor do?

The sensor is located in the outlet of the air cleaner housing, which provides a consistent location for the sensor while communicating air flow data to the ECM, optimizing engine and system performance.

Why is Direct Flow required for Tier 4?

The Direct Flow air cleaner has been designed and integrated with the Cummins Engine Business in order to understand and match the engine performance requirements and industrial specifications for the air intake system. The sensor must be mounted at a specific location in the airstream for accurate calculations, therefore, the Direct Flow housing has been specifically designed to minimize variation and achieve optimized system performance.

What does a pre-cleaner do?

A pre-cleaner is used to remove about 75% of all incoming dust from reaching the filter element. A pre-cleaner uses centrifugal force to move dust particles out of the air stream and then expels these particles back into the environment.

What is aspiration?

Aspirating the air cleaner increases the efficiency of the pre-cleaner by pulling a small vacuum and extracting the large dust particles from the pre-cleaner. Typically, the efficiency of most pre-cleaners is 75%, an aspirated pre-cleaner is normally 90% efficient. This increase in efficiency increases the life of the filter element about 250%. Aspirating the air cleaner is done by installing an aspirator within the exhaust flow; the aspirator uses a venturi to create a pressure differential which provides the vacuum pressure to the air cleaner. For more information, contact Technical Assistance at 1-800-22FILTER.

Can Direct Flow™ be used for Tier 3 applications?

Absolutely. The Direct Flow™ air cleaner has been designed to operate in any air filtration environment.

OptiAir™ Air Cleaners

Innovative Design Meets All OEM Requirements

- Reduction in system size to fit shrinking engine compartments
- Higher dust holding capacity to extend service intervals
- Two-stage air housing design to extend filter life
- Lower system restriction to deliver maximum engine performance
- Reduced service time to lower maintenance costs
- Secondary element optional

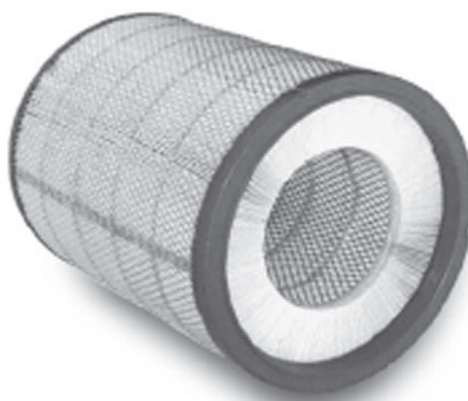

The OptiAir Advantage

Outlet Options
Systems available in both straight and 90° rotatable designs

Two-Stage Air Housing Design
Removes large particulates, extending filter life

Mono Latch Twist Lock™ Cover with Multi-Locking Positions
Installation flexibility, easy to service, reduced maintenance time

Increased Outlet Area
Increased area resulting in reduced restriction

Pressure Tap
Easy-to-install filter restriction gauge option

Highly Durable Resin Construction
Plastic or metal mounting options

Optional Secondary Element Design
Added engine protection

Quick reference Service Label
Replacement filter information

Dust Ejection Valve
Removal of large particulates and moisture

Increased Filter Media Area
Greater capacity - longer filter life

Highly Resistant Urethane Seal
Excellent sealing capacity



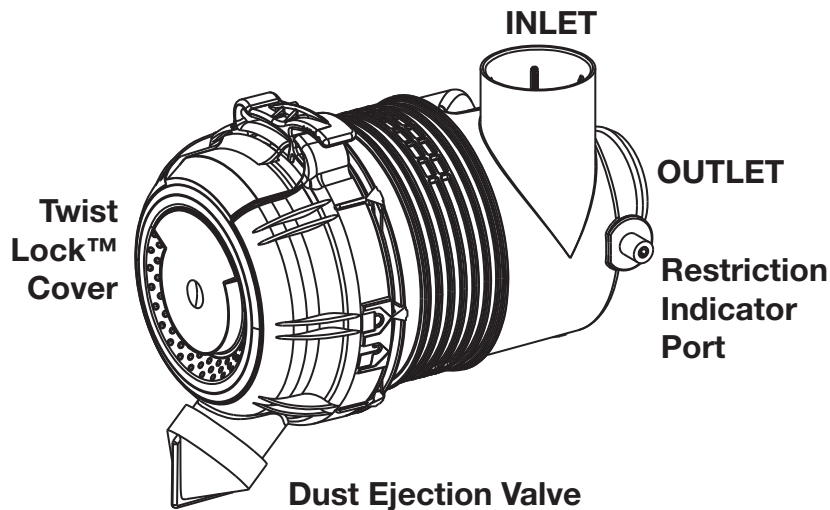

Specifications

Specification	AH19474	AH19496
Length Overall	9.3" (237.1 mm)	9.3" (237.1 mm)
Cover OD	5.6" (141.6 mm)	5.6" (141.6 mm)
Flow, Min. (2" restriction)	38 CFM (1.1 m ³ /min)	30 CFM (0.8 m ³ /min)
Flow, Max. (12" restriction)	102 CFM (2.9 m ³ /min)	83 CFM (2.4 m ³ /min)
Secondary Element	No	Yes
Housing Material	Glass-Filled Polypropylene	Glass-Filled Polypropylene
Pre-Cleaner Integral	Yes	Yes
Outlet	Straight	Straight
Filter Efficiency	≥ 99.90% per ISO 5011	≥ 99.90% per ISO 5011

Dust Holding Capacity per Cummins® Specification

Specification	AH19474	AH19496
Allowable Flow for 10 g/CFM	< 63 CFM (1.8 m ³ /min)	< 57 CFM (1.6 m ³ /min)
Allowable Flow for 25 g/CFM	< 35 CFM (1.0 m ³ /min)	< 34 CFM (1.0 m ³ /min)

Specifications subject to change without notice.

Ordering Information

Air Cleaners	
Part Number	Description
AH19474	OptiAir™ 400 Series Air Cleaner – without Secondary Element – with Straight Outlet
AH19496	OptiAir 400 Series Air Cleaner – with Secondary Element – with Straight Outlet

Accessories	
Part Number	Description
3918199 S	Mounting Bracket
1	No. of Brackets Required
3316653 S	Outlet Band Clamps
3918194 S	Weather Hood
N/A	Hump-Hose
3316564 S	90° Elbow
N/A	90° Reducing Elbow
3946326 S	Restriction Indicator

Service Parts	
Part Number	Description
AF26116	Primary Element
N/A	Magnum Primary Element
AF26350	Secondary Element
3946457 S	Dust Ejection Valve
3946459 S	Cover Assembly

Dimensions

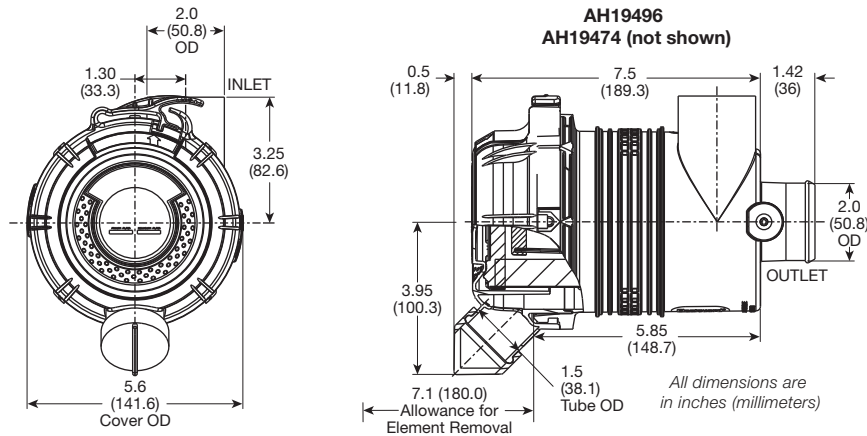

Performance

System Restriction vs Flow Rate

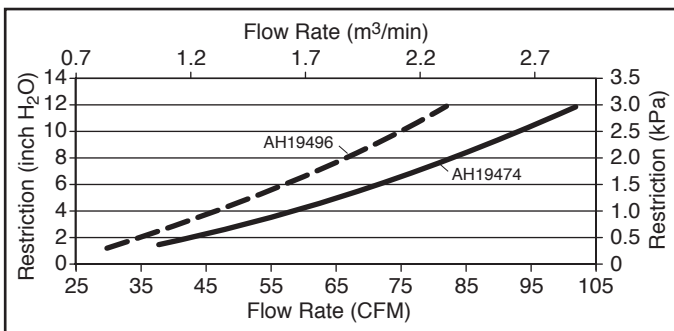

Typical System Capacity vs Flow Rate

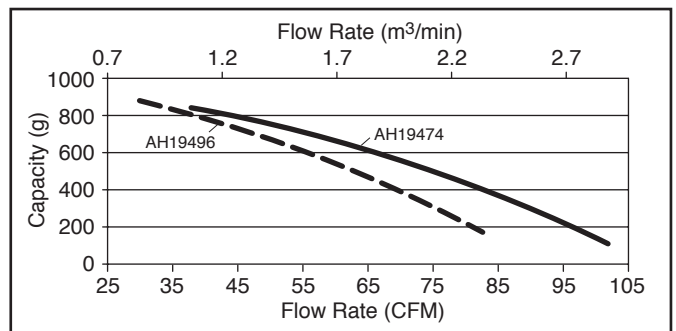

Restriction		Flow Rate () = with Secondary		Typical Capacity () = with Secondary
in H ₂ O	kPa	CFM	m ³ /min	grams
6	1.5	70 (55)	1.98 (1.56)	571 (610)
8	2.0	82 (65)	2.32 (1.84)	420 (465)
10	2.5	93 (74)	2.63 (2.10)	257 (329)
12	3.0	102 (83)	2.89 (2.35)	115 (170)

ISO Coarse Dust
2.0 g/m³ Feed Rate
6.25 kPa (25" H₂O) Terminal Restriction



400 Series – 90° Outlet

OptiAir

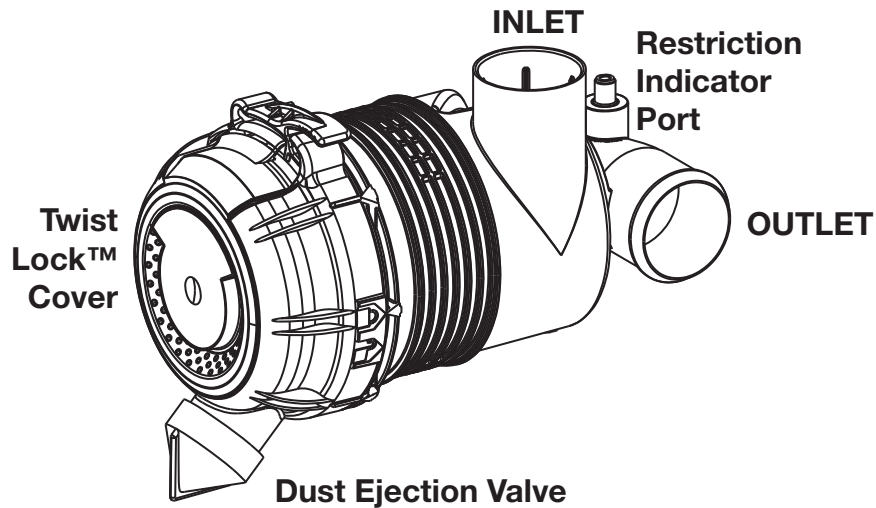

Specifications

Specification	AH19485	AH19484
Length Overall	10.4" (263.3 mm)	10.4" (263.3 mm)
Cover OD	5.6" (141.6 mm)	5.6" (141.6 mm)
Flow, Min. (2" restriction)	35 CFM (1.0 m ³ /min)	25 CFM (0.7 m ³ /min)
Flow, Max. (12" restriction)	92 CFM (2.6 m ³ /min)	80 CFM (2.3 m ³ /min)
Secondary Element	No	Yes
Housing Material	Glass-Filled Polypropylene	Glass-Filled Polypropylene
Pre-cleaner Integral	Yes	Yes
Outlet	90° Elbow	90° Elbow
Filter Efficiency	≥ 99.90% per ISO 5011	≥ 99.90% per ISO 5011

Dust Holding Capacity per Cummins® Specification

Specification	AH19485	AH19484
Allowable Flow for 10 g/CFM	< 57 CFM (1.6 m ³ /min)	< 55 CFM (1.6 m ³ /min)
Allowable Flow for 25 g/CFM	< 32 CFM (0.9 m ³ /min)	< 31 CFM (0.9 m ³ /min)

Specifications subject to change without notice.

Ordering Information

Air Cleaners	
Part Number	Description
AH19485	OptiAir™ 400 Series Air Cleaner – without Secondary Element – with 90° Outlet
AH19484	OptiAir 400 Series Air Cleaner – with Secondary Element – with 90° Outlet

Accessories	
Part Number	Description
3918199 S	Mounting Bracket
1	No. of Brackets Required
3316653 S	Outlet Band Clamps
3918194 S	Weather Hood
N/A	Hump-Hose
3316564 S	90° Elbow
N/A	90° Reducing Elbow
3946326 S	Restriction Indicator

Service Parts	
Part Number	Description
AF26116	Primary Element
N/A	Magnum Primary Element
AF26350	Secondary Element
3946457 S	Dust Ejection Valve
3946459 S	Cover Assembly

Dimensions

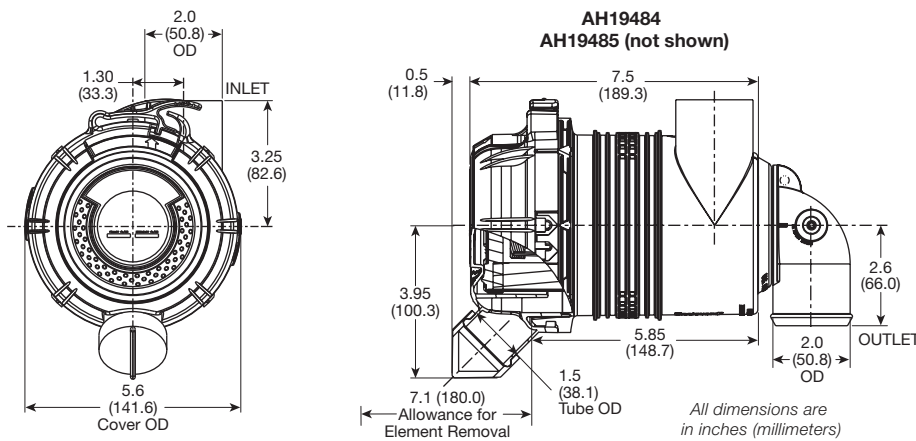

Performance

System Restriction vs Flow Rate

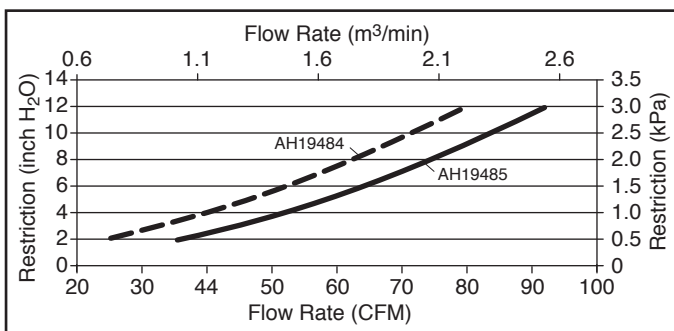

Typical System Capacity vs Flow Rate

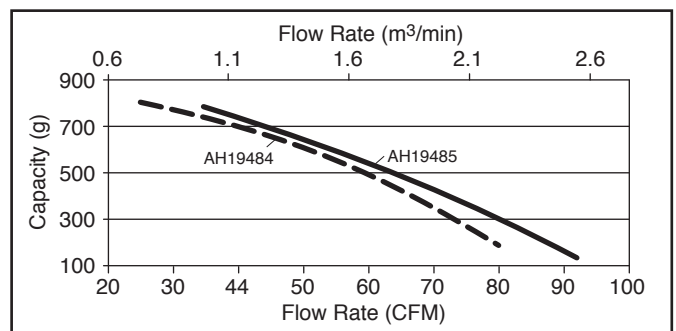

Restriction		Flow Rate () = with Secondary		Typical Capacity () = with Secondary
in H ₂ O	kPa	CFM	m ³ /min	grams
6	1.5	64 (52)	1.81 (1.47)	502 (580)
8	2.0	75 (63)	2.12 (1.78)	364 (450)
10	2.5	84 (72)	2.38 (2.04)	250 (320)
12	3.0	92 (80)	2.61 (2.27)	135 (190)

ISO Coarse Dust
2.0 g/m³ Feed Rate
6.25 kPa (25" H₂O) Terminal Restriction



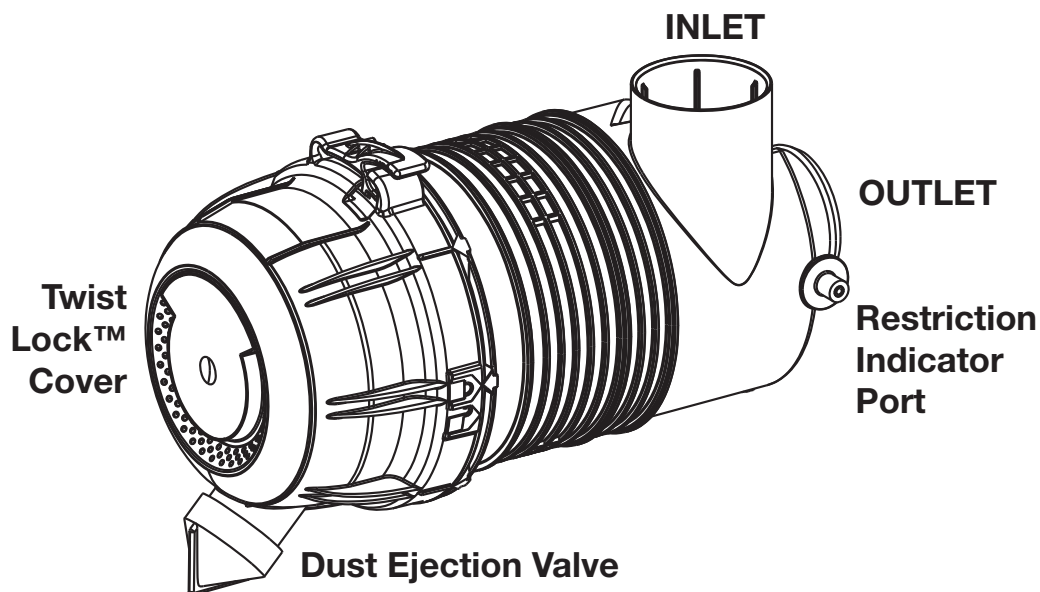

Specifications

Specification	AH19483	AH19482
Length Overall	13.1" (332.3 mm)	13.1" (332.3 mm)
Cover OD	6.5" (166.0 mm)	6.5" (166.0 mm)
Flow, Min. (2" restriction)	60 CFM (1.7 m ³ /min)	45 CFM (1.3 m ³ /min)
Flow, Max. (12" restriction)	163 CFM (4.6 m ³ /min)	120 CFM (3.4 m ³ /min)
Secondary Element	No	Yes
Housing Material	Glass-Filled Polypropylene	Glass-Filled Polypropylene
Pre-cleaner Integral	Yes	Yes
Outlet	Straight	Straight
Filter Efficiency	≥ 99.90% per ISO 5011	≥ 99.90% per ISO 5011

Dust Holding Capacity per Cummins® Specification

Specification	AH19483	AH19482
Allowable Flow for 10 g/CFM	< 141 CFM (4.0 m ³ /min)	< 116 CFM (3.3 m ³ /min)
Allowable Flow for 25 g/CFM	< 85 CFM (2.4 m ³ /min)	< 74 CFM (2.1 m ³ /min)

Specifications subject to change without notice.

Ordering Information

Air Cleaners	
Part Number	Description
AH19483	OptiAir™ 500 Series Air Cleaner – without Secondary Element – with Straight Outlet
AH19482	OptiAir 500 Series Air Cleaner – with Secondary Element – with Straight Outlet

Accessories	
Part Number	Description
3918198 S	Mounting Bracket
1	No. of Brackets Required
3316654 S	Outlet Band Clamps
3918193 S	Weather Hood
N/A	Hump-Hose
3316565 S	90° Elbow
N/A	90° Reducing Elbow
3946326 S	Restriction Indicator

Service Parts	
Part Number	Description
AF26168	Primary Element
N/A	Magnum Primary Element
AF26351	Secondary Element
3946457 S	Dust Ejection Valve
3946460 S	Cover Assembly

Dimensions

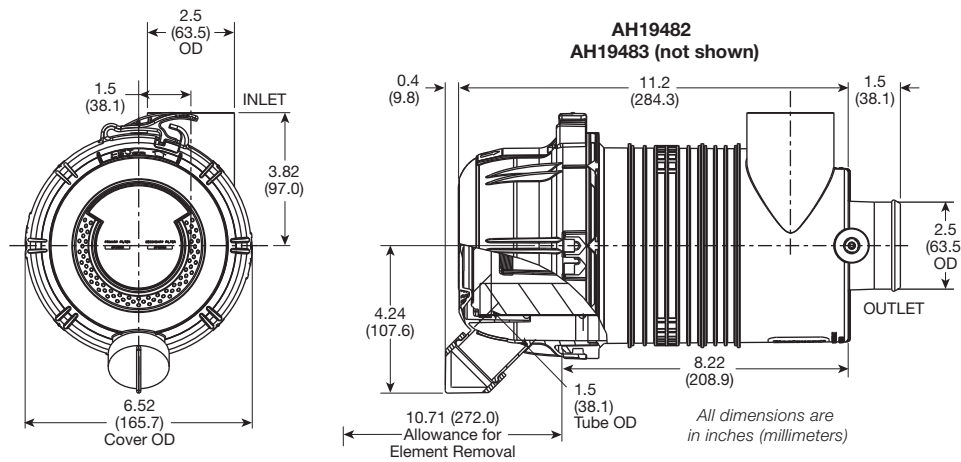

Performance

System Restriction vs Flow Rate

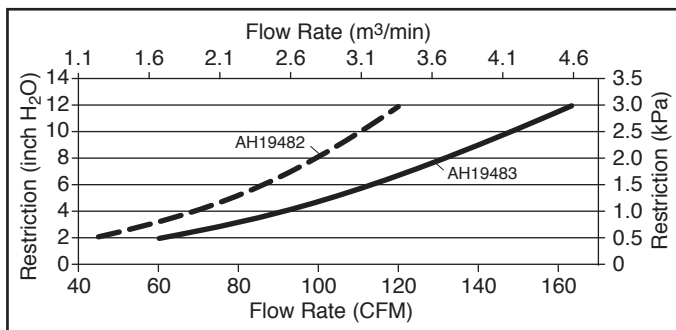

Typical System Capacity vs Flow Rate

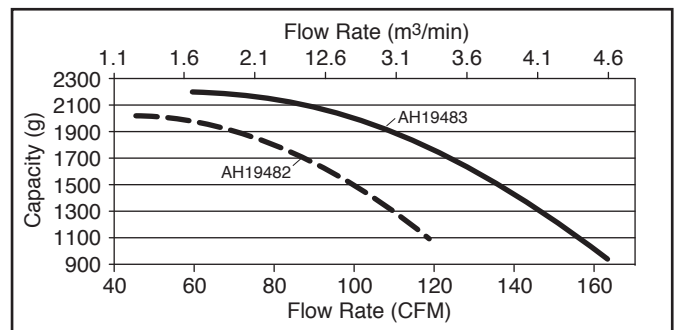

Restriction		Flow Rate () = with Secondary		Typical Capacity () = with Secondary
in H ₂ O	kPa	CFM	m ³ /min	grams
6	1.5	112 (87)	3.17 (2.46)	1845 (1700)
8	2.0	132 (100)	3.74 (2.83)	1585 (1465)
10	2.5	147 (111)	4.16 (3.14)	1300 (1285)
12	3.0	163 (120)	4.62 (3.40)	930 (1050)

ISO Coarse Dust
2.0 g/m³ Feed Rate
6.25 kPa (25" H₂O) Terminal Restriction



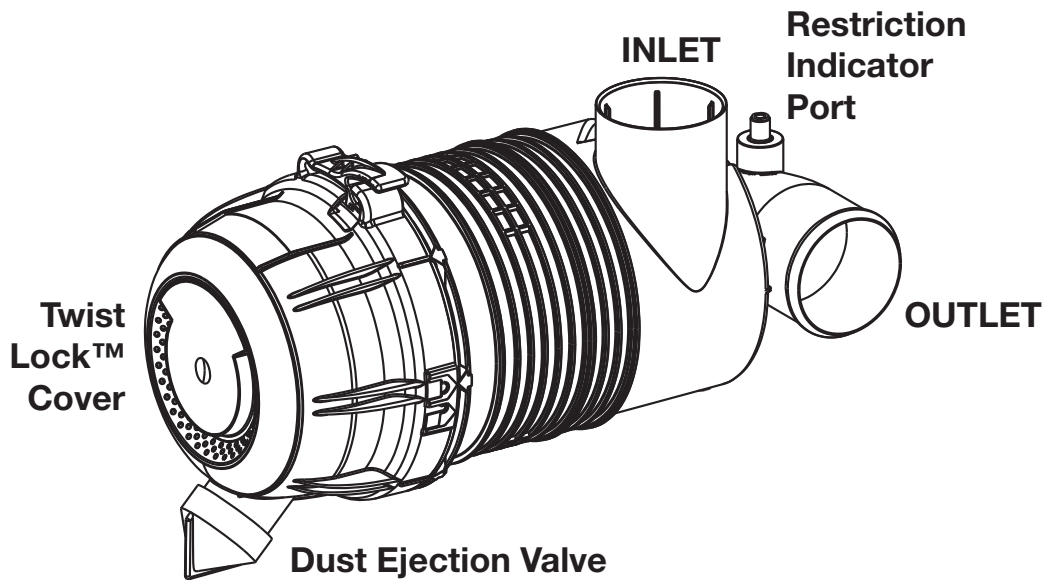

Specifications

Specification	AH19487	AH19486
Length Overall	14.5" (368.3 mm)	14.5" (368.3 mm)
Cover OD	6.5" (166.0 mm)	6.5" (166.0 mm)
Flow, Min. (2" restriction)	70 CFM (2.0 m ³ /min)	40 CFM (1.1 m ³ /min)
Flow, Max. (12" restriction)	145 CFM (4.1 m ³ /min)	110 CFM (3.1 m ³ /min)
Secondary Element	No	Yes
Housing Material	Glass-Filled Polypropylene	Glass-Filled Polypropylene
Pre-cleaner Integral	Yes	Yes
Outlet	90° Elbow	90° Elbow
Filter Efficiency	≥ 99.90% per ISO 5011	≥ 99.90% per ISO 5011

Dust Holding Capacity per Cummins® Specification

Specification	AH19487	AH19486
Allowable Flow for 10 g/CFM	< 127 CFM (3.6 m ³ /min)	< 105 CFM (3.0 m ³ /min)
Allowable Flow for 25 g/CFM	< 85 CFM (2.4 m ³ /min)	< 79 CFM (2.2 m ³ /min)

Specifications subject to change without notice.

Ordering Information

Air Cleaners	
Part Number	Description
AH19487	OptiAir™ 500 Series Air Cleaner – without Secondary Element – with 90° Outlet
AH19486	OptiAir 500 Series Air Cleaner – with Secondary Element – with 90° Outlet

Accessories	
Part Number	Description
3918198 S	Mounting Bracket
1	No. of Brackets Required
3316654 S	Outlet Band Clamps
3918193 S	Weather Hood
N/A	Hump-Hose
3316565 S	90° Elbow
N/A	90° Reducing Elbow
3946326 S	Restriction Indicator

Service Parts	
Part Number	Description
AF26168	Primary Element
N/A	Magnum Primary Element
AF26351	Secondary Element
3946457 S	Dust Ejection Valve
3946460 S	Cover Assembly

Dimensions

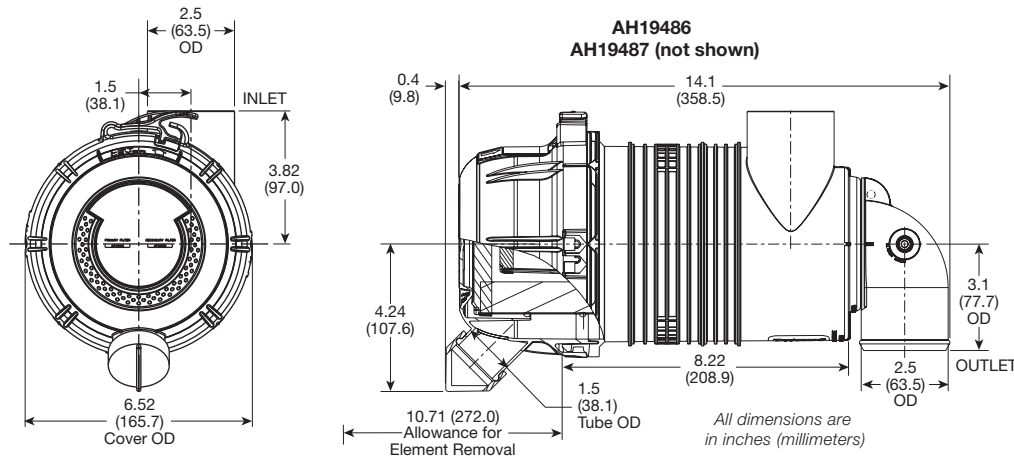

Performance

System Restriction vs Flow Rate

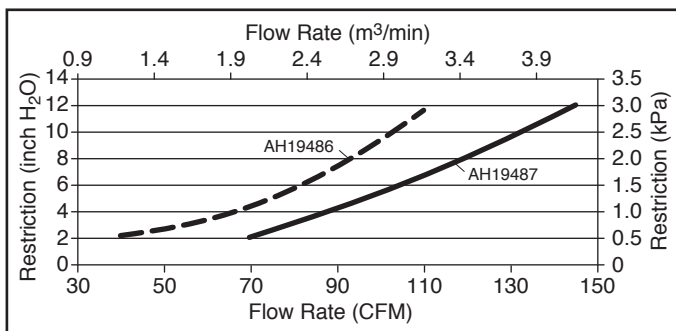

Typical System Capacity vs Flow Rate

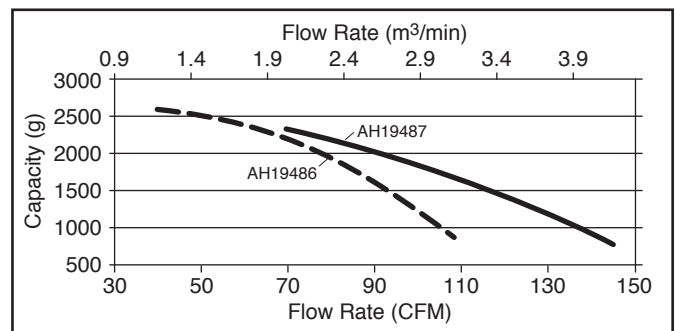

Restriction		Flow Rate () = with Secondary		Typical Capacity () = with Secondary
in H ₂ O	kPa	CFM	m ³ /min	grams
6	1.5	105 (81)	2.97 (2.29)	1747 (1880)
8	2.0	119 (96)	3.37 (2.72)	1470 (1420)
10	2.5	134 (105)	3.79 (2.97)	1130 (1040)
12	3.0	145 (110)	4.11 (3.11)	750 (800)

ISO Coarse Dust
2.0 g/m³ Feed Rate
6.25 kPa (25" H₂O) Terminal Restriction

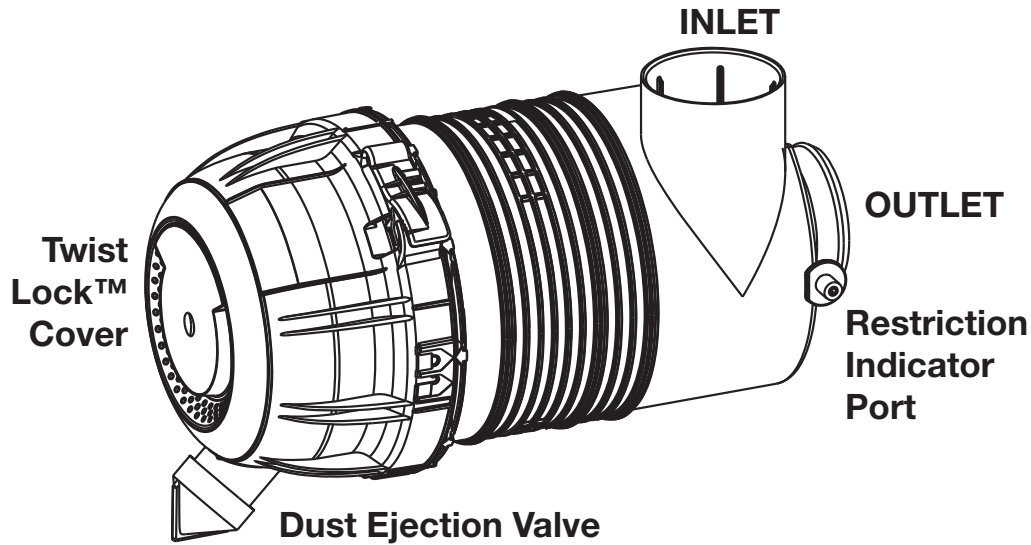

Specifications

Specification	AH19476	AH19477
Length Overall	14.8" (375.1 mm)	14.8" (375.1 mm)
Cover OD	7.6" (193.7 mm)	7.6" (193.7 mm)
Flow, Min. (2" restriction)	98 CFM (2.8 m ³ /min)	80 CFM (2.3 m ³ /min)
Flow, Max. (12" Restriction)	240 CFM (6.8 m ³ /min)	206 CFM (5.8 m ³ /min)
Secondary Element	No	Yes
Housing Material	Glass-Filled Polypropylene	Glass-Filled Polypropylene
Pre-cleaner Integral	Yes	Yes
Outlet	Straight	Straight
Filter Efficiency	≥ 99.90% per ISO 5011	≥ 99.90% per ISO 5011

Dust Holding Capacity per Cummins® Specification

Specification	AH19476	AH19477
Allowable Flow for 10 g/CFM	< 212 CFM (6.0 m ³ /min)	< 191 CFM (5.4 m ³ /min)
Allowable Flow for 25 g/CFM	< 135 CFM (3.8 m ³ /min)	< 126 CFM (3.6 m ³ /min)

Specifications subject to change without notice.

Ordering Information

Air Cleaners	
Part Number	Description
AH19476	OptiAir™ 600 Series Air Cleaner – without Secondary Element – with Straight Outlet
AH19477	OptiAir 600 Series Air Cleaner – with Secondary Element – with Straight Outlet

Accessories	
Part Number	Description
3918196 S	Mounting Bracket
1	No. of Brackets Required
3316656 S	Outlet Band Clamps
3946322 S	Weather Hood
3316606 S	Hump-Hose
3316566 S	90° Elbow
N/A	90° Reducing Elbow
3946326 S	Restriction Indicator

Service Parts	
Part Number	Description
AF26117	Primary Element
N/A	Magnum Primary Element
AF26118	Secondary Element
3946457 S	Dust Ejection Valve
3946461 S	Cover Assembly

Dimensions

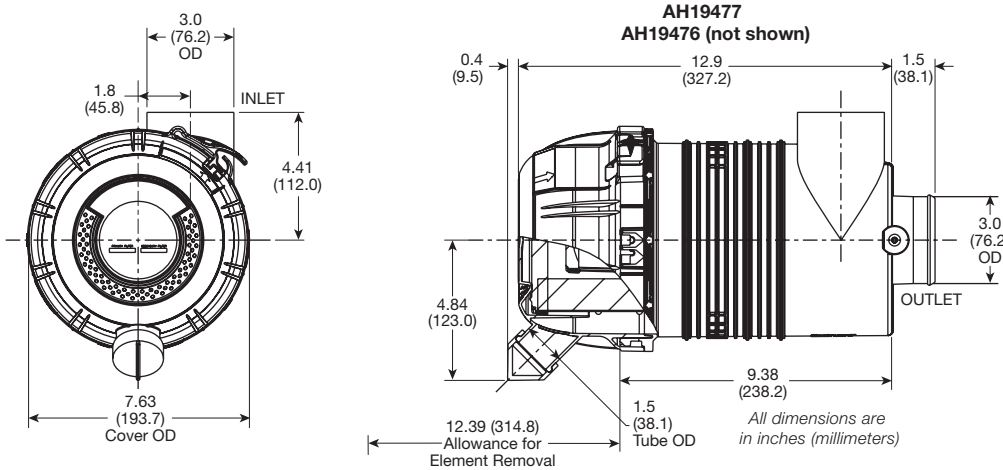

Performance

System Restriction vs Flow Rate

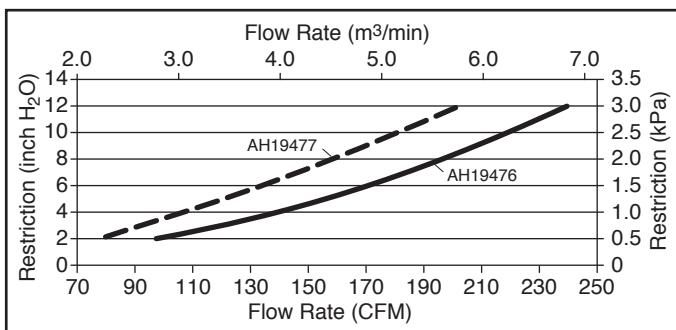

Typical System Capacity vs Flow Rate

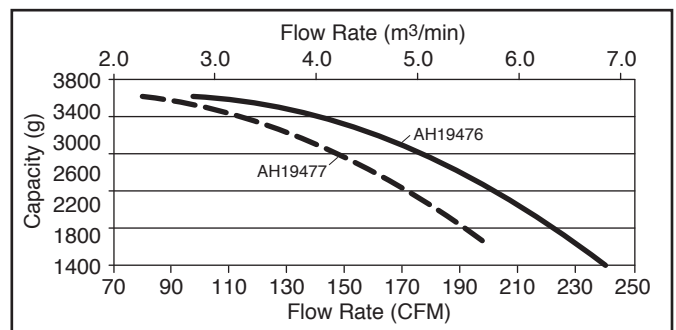

Restriction		Flow Rate () = with Secondary		Typical Capacity () = with Secondary
in H ₂ O	kPa	CFM	m ³ /min	grams
6	1.5	171 (135)	4.84 (3.82)	2930 (3024)
8	2.0	198 (160)	5.61 (4.53)	2425 (2578)
10	2.5	219 (180)	6.20 (5.10)	1986 (2184)
12	3.0	240 (202)	6.80 (5.72)	1400 (1600)

ISO Coarse Dust
2.0 g/m³ Feed Rate
6.25 kPa (25" H₂O) Terminal Restriction

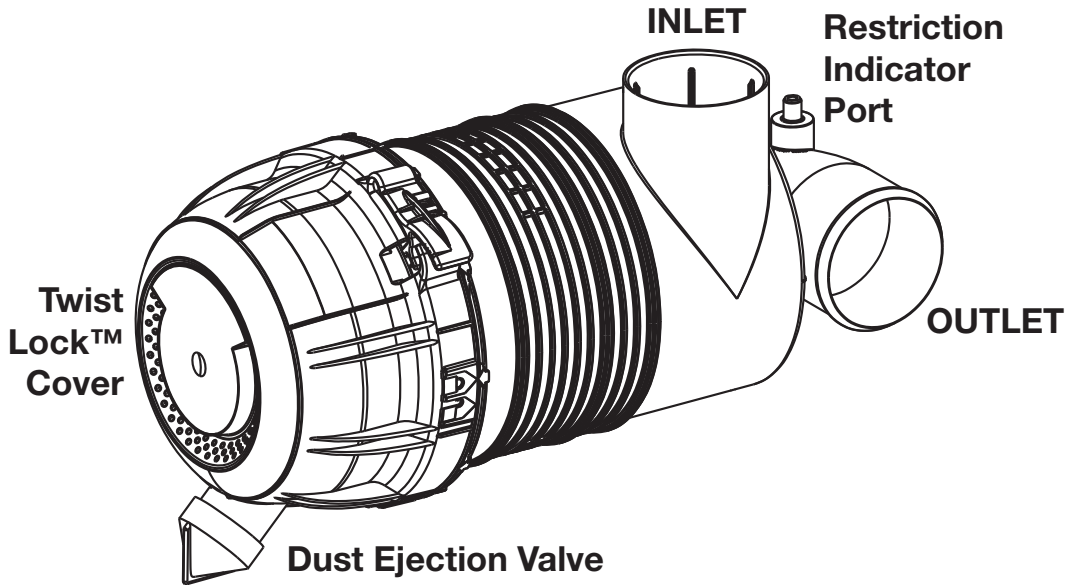

Specifications

Specification	AH19489	AH19488
Length Overall	16.7" (423.3 mm)	16.7" (423.3 mm)
Cover OD	7.6" (193.7 mm)	7.6" (193.7 mm)
Flow, Min. (2" restriction)	85 CFM (2.4 m ³ /min)	70 CFM (2.0 m ³ /min)
Flow, Max. (12" restriction)	213 CFM (6.0 m ³ /min)	175 CFM (5.0 m ³ /min)
Secondary Element	No	Yes
Housing Material	Glass-Filled Polypropylene	Glass-Filled Polypropylene
Pre-cleaner Integral	Yes	Yes
Outlet	90 ° Elbow	90 ° Elbow
Filter Efficiency	≥ 99.90% per ISO 5011	≥ 99.90% per ISO 5011

Dust Holding Capacity per Cummins® Specification

Specification	AH19489	AH19488
Allowable Flow for 10 g/CFM	< 196 CFM (5.6 m ³ /min)	< 175 CFM (5.0 m ³ /min)*
Allowable Flow for 25 g/CFM	< 132 CFM (3.7 m ³ /min)	< 128 CFM (3.6 m ³ /min)

* Flow rate limited by restriction

Specifications subject to change without notice.

Ordering Information

Air Cleaners	
Part Number	Description
AH19489	OptiAir™ 600 Series Air Cleaner – without Secondary Element – with 90° Outlet
AH19488	OptiAir 600 Series Air Cleaner – with Secondary Element – with 90° Outlet

Accessories	
Part Number	Description
3918196 S	Mounting Bracket
1	No. of Brackets Required
3316656 S	Outlet Band Clamps
3946322 S	Weather Hood
3316606 S	Hump-Hose
3316566 S	90° Elbow
N/A	90° Reducing Elbow
3946326 S	Restriction Indicator

Service Parts	
Part Number	Description
AF26117	Primary Element
N/A	Magnum Primary Element
AF26118	Secondary Element
3946457 S	Dust Ejection Valve
3946461 S	Cover Assembly

Dimensions

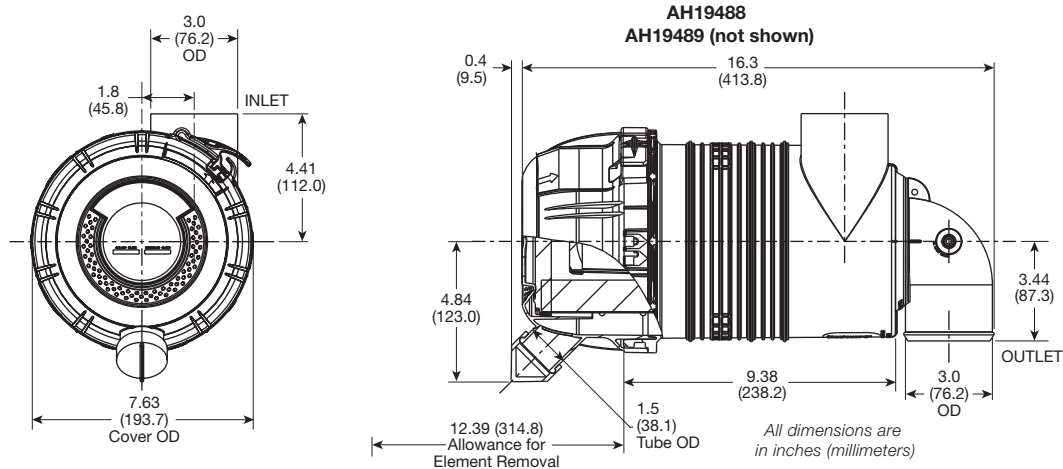

Performance

System Restriction vs Flow Rate

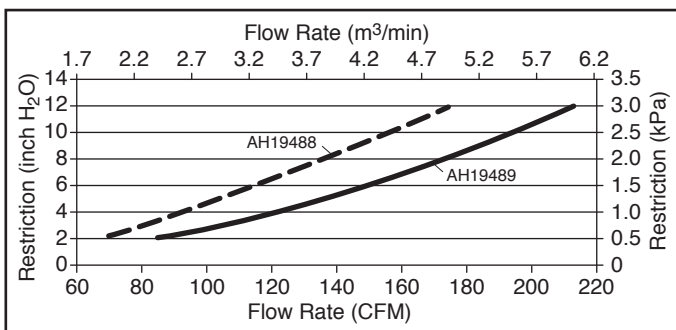

Typical System Capacity vs Flow Rate

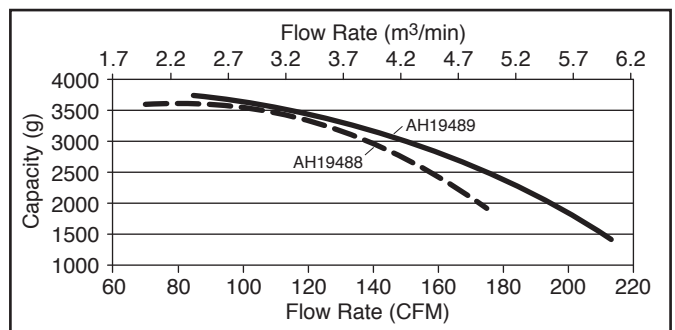

Restriction		Flow Rate () = with Secondary		Typical Capacity () = with Secondary
in H ₂ O	kPa	CFM	m ³ /min	grams
6	1.5	148 (115)	4.19 (3.26)	3000 (3400)
8	2.0	175 (138)	4.96 (3.91)	2459 (3000)
10	2.5	195(157)	5.52 (4.45)	1986 (2510)
12	3.0	213 (175)	6.03 (4.96)	1450 (1925)

ISO Coarse Dust
2.0 g/m³ Feed Rate
6.25 kPa (25" H₂O) Terminal Restriction

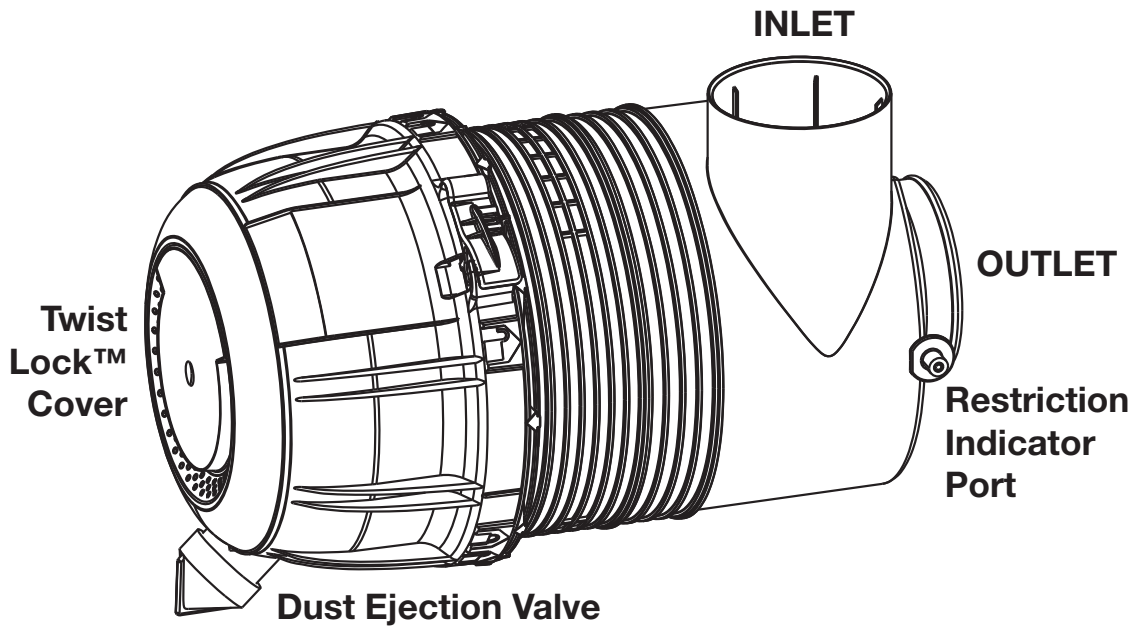

Specifications

Specification	AH19261	AH19260
Length Overall	16.2" (411.0 mm)	16.2" (411.0 mm)
Cover OD	9.3" (237.0 mm)	9.3" (237.0 mm)
Flow, Min. (2" restriction)	175 CFM (5.0 m ³ /min)	103 CFM (2.9 m ³ /min)
Flow, Max. (12" restriction)	388 CFM (11.0 m ³ /min)	290 CFM (8.2 m ³ /min)
Secondary Element	No	Yes
Housing Material	Glass-Filled Polypropylene	Glass-Filled Polypropylene
Pre-cleaner Integral	Yes	Yes
Outlet	Straight	Straight
Filter Efficiency	≥ 99.90% per ISO 5011	≥ 99.90% per ISO 5011

Dust Holding Capacity per Cummins® Specification

Specification	AH19261	AH19260
Allowable Flow for 10 g/CFM	< 336 CFM (9.5 m ³ /min)	< 285 CFM (8.1 m ³ /min)
Allowable Flow for 25 g/CFM	< 216 CFM (6.1 m ³ /min)	< 206 CFM (5.8 m ³ /min)

Specifications subject to change without notice.

Ordering Information

Air Cleaners	
Part Number	Description
AH19261	OptiAir™ 800 Series Air Cleaner – without Secondary Element – with Straight Outlet
AH19260	OptiAir 800 Series Air Cleaner – with Secondary Element – with Straight Outlet

Accessories	
Part Number	Description
3918197 S	Mounting Bracket
1	No. of Brackets Required
3316658 S	Outlet Band Clamps
3946458 S	Weather Hood
3316608 S	Hump-Hose
3316568 S	90° Elbow
N/A	90° Reducing Elbow
3946326 S	Restriction Indicator

Service Parts	
Part Number	Description
AF25960	Primary Element
N/A	Magnum Primary Element
AF25961	Secondary Element
3946457 S	Dust Ejection Valve
3946462 S	Cover Assembly

Dimensions

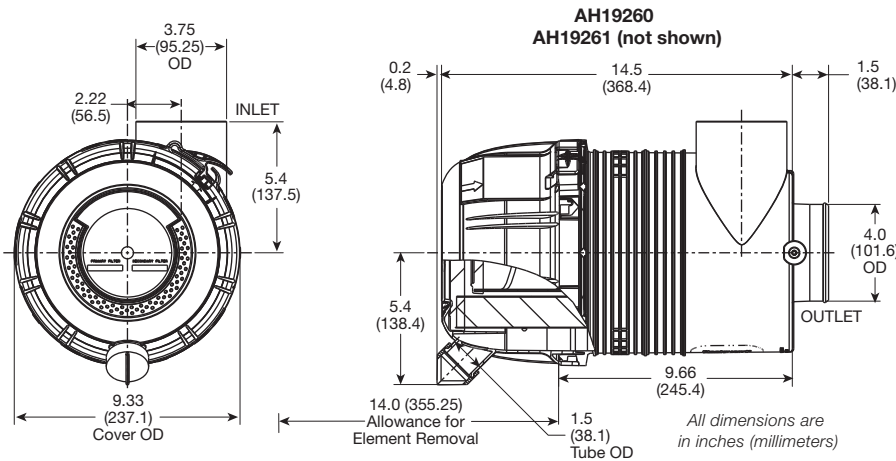

Performance

System Restriction vs Flow Rate

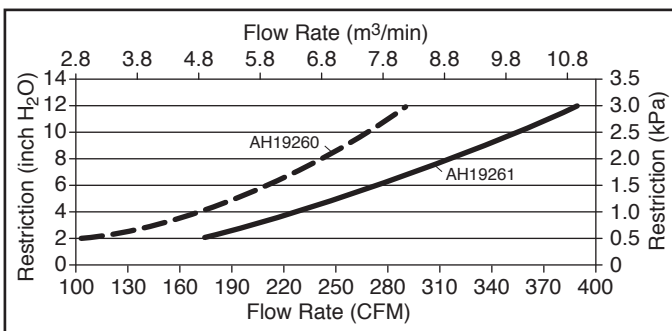

Typical System Capacity vs Flow Rate

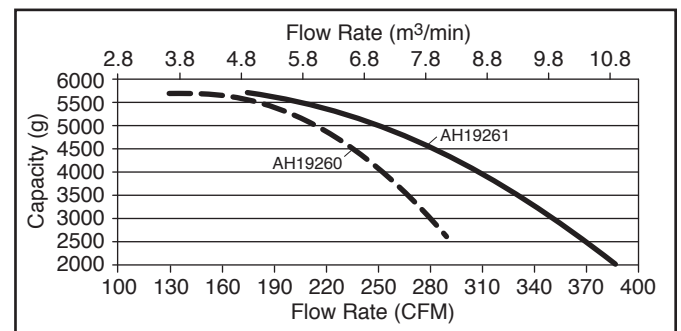

Restriction		Flow Rate () = with Secondary		Typical Capacity () = with Secondary
in H ₂ O	kPa	CFM	m ³ /min	grams
6	1.5	275 (207)	7.79 (5.86)	4583 (5155)
8	2.0	317 (242)	8.98 (6.85)	3857 (4369)
10	2.5	355 (270)	10.05 (7.65)	2844 (3392)
12	3.0	388 (290)	10.99 (8.21)	2012 (2600)

ISO Coarse Dust
2.0 g/m³ Feed Rate
6.25 kPa (25" H₂O) Terminal Restriction

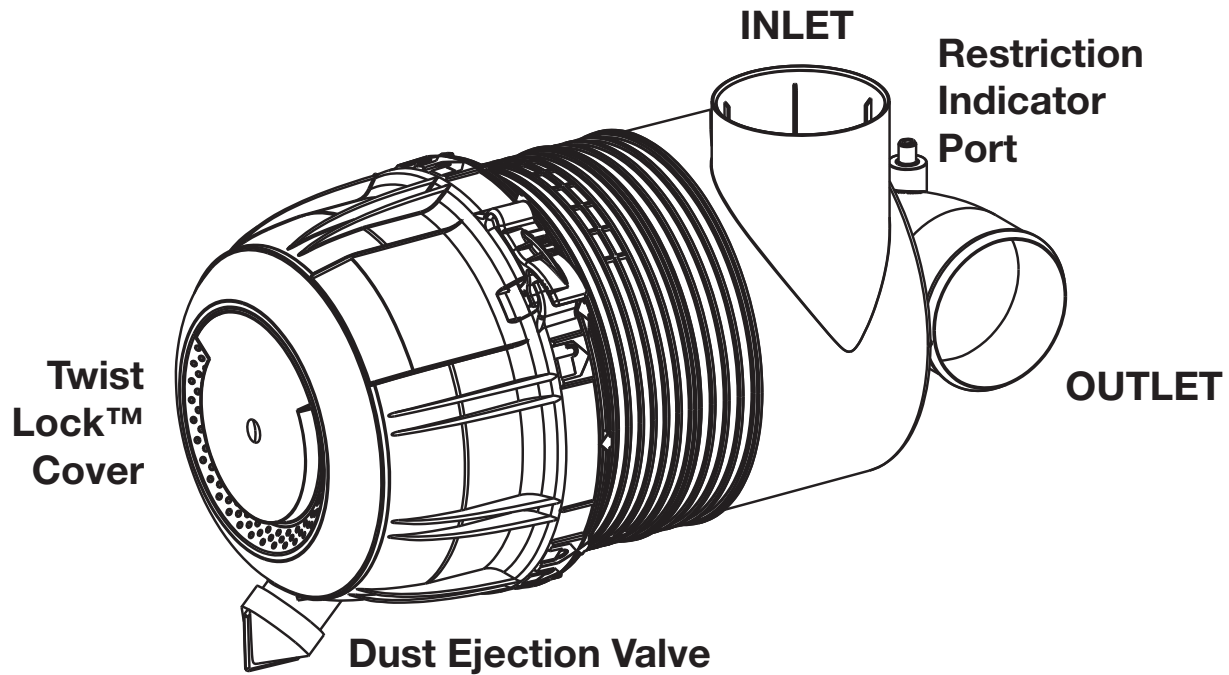

Specifications

Specification	AH19491	AH19490
Length Overall	18.6" (472.1 mm)	18.6" (472.1 mm)
Cover OD	9.3" (237.0 mm)	9.3" (237.0 mm)
Flow, Min. (2" restriction)	130 CFM (3.7 m³/min)	100 CFM (2.8 m³/min)
Flow, Max. (12" restriction)	330 CFM (9.3 m³/min)	266 CFM (7.5 m³/min)
Secondary Element	No	Yes
Housing Material	Glass-Filled Polypropylene	Glass-Filled Polypropylene
Pre-cleaner Integral	Yes	Yes
Outlet	90° Outlet	90° Outlet
Filter Efficiency	≥ 99.90% per ISO 5011	≥ 99.90% per ISO 5011

Dust Holding Capacity per Cummins® Specification

Specification	AH19491	AH19490
Allowable Flow for 10 g/CFM	< 321 CFM (9.1 m³/min)	< 266 CFM (7.5 m³/min)*
Allowable Flow for 25 g/CFM	< 212 CFM (6.0 m³/min)	< 191 CFM (5.4 m³/min)

* Flow rate limited by restriction.

Specifications subject to change without notice.

Ordering Information

Air Cleaners	
Part Number	Description
AH19491	OptiAir™ 800 Series Air Cleaner – without Secondary Element – with 90° Outlet
AH19490	OptiAir 800 Series Air Cleaner – with Secondary Element – with 90° Outlet

Accessories	
Part Number	Description
3918197 S	Mounting Bracket
1	No. of Brackets Required
3316657 S	Outlet Band Clamps
3946458 S	Weather Hood
3316608 S	Hump-Hose
3316568 S	90° Elbow
N/A	90° Reducing Elbow
3946326 S	Restriction Indicator

Service Parts	
Part Number	Description
AF25960	Primary Element
N/A	Magnum Primary Element
AF25961	Secondary Element
3946457 S	Dust Ejection Valve
3946462 S	Cover Assembly

Dimensions

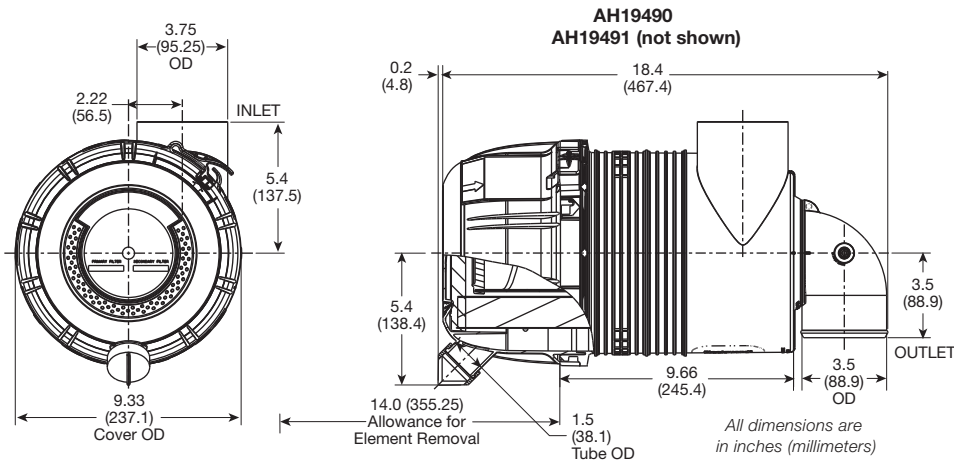

Performance

System Restriction vs Flow Rate

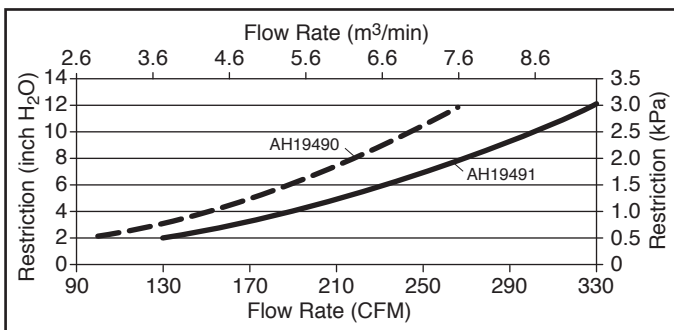

Typical System Capacity vs Flow Rate

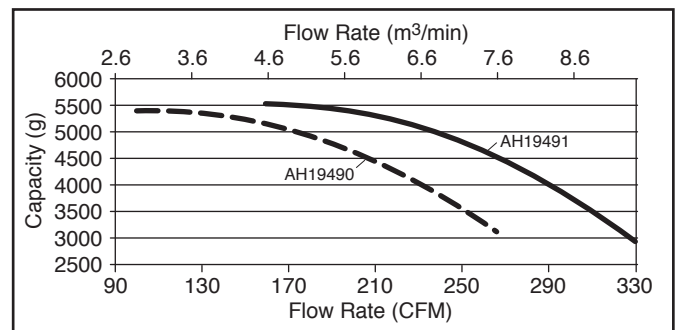

Restriction		Flow Rate () = with Secondary		Typical Capacity () = with Secondary
in H ₂ O	kPa	CFM	m ³ /min	grams
6	1.5	233 (190)	6.60 (5.38)	5095 (4756)
8	2.0	270 (220)	7.65 (6.23)	4525 (4300)
10	2.5	300(247)	8.50 (7.00)	3730(3640)
12	3.0	330 (266)	9.35 (7.53)	2950 (3105)

ISO Coarse Dust
2.0 g/m³ Feed Rate
6.25 kPa (25" H₂O) Terminal Restriction

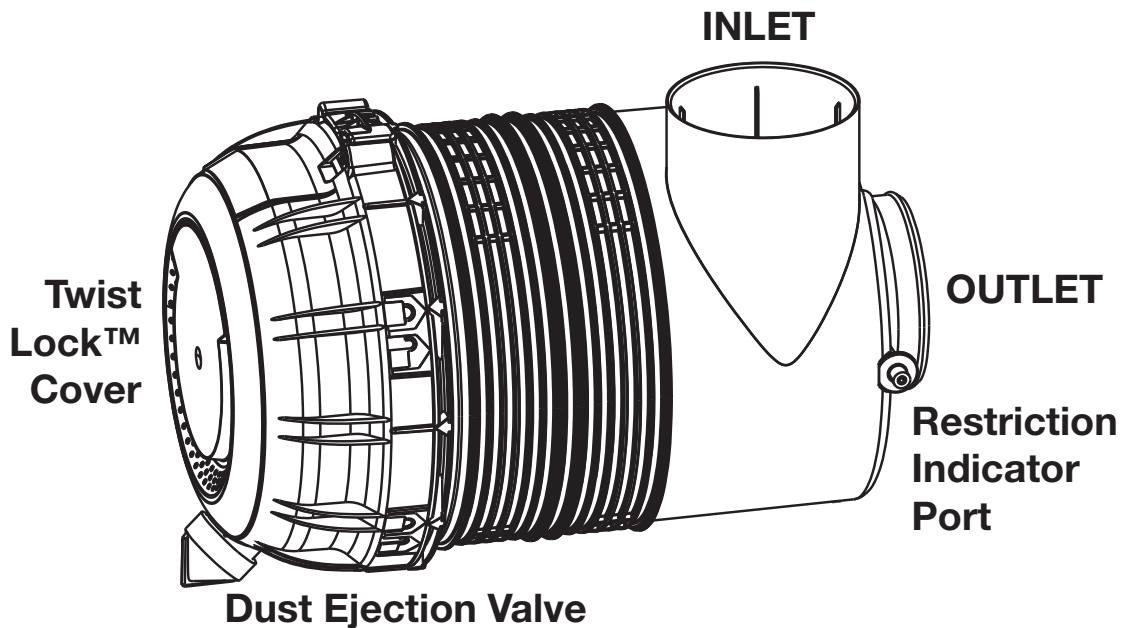

Specifications

Specification	AH19478	AH19479
Length Overall	17.4" (442.6 mm)	17.4" (442.6 mm)
Cover OD	10.7" (272.0 mm)	10.7" (272.0 mm)
Flow, Min. (2" restriction)	200 CFM (5.7 m ³ /min)	175 CFM (5.0 m ³ /min)
Flow, Max. (12" restriction)	507 CFM (14.4 m ³ /min)	411 CFM (11.6 m ³ /min)
Secondary Element	No	Yes
Housing Material	Glass-Filled Polypropylene	Glass-Filled Polypropylene
Pre-cleaner Integral	Yes	Yes
Outlet	Straight	Straight
Filter Efficiency	≥ 99.90% per ISO 5011	≥ 99.90% per ISO 5011

Dust Holding Capacity per Cummins® Specification

Specification	AH19478	AH19479
Allowable Flow for 10 g/CFM	< 489 CFM (13.9 m ³ /min)	< 411 CFM (11.6 m ³ /min)*
Allowable Flow for 25 g/CFM	< 323 CFM (9.1 m ³ /min)	< 315 CFM (8.9 m ³ /min)

* Flow rate limited by restriction.

Specifications subject to change without notice.

Ordering Information

Air Cleaners	
Part Number	Description
AH19478	OptiAir™ 1000 Series Air Cleaner – without Secondary Element – with Straight Outlet
AH19479	OptiAir 1000 Series Air Cleaner – with Secondary Element – with Straight Outlet

Accessories	
Part Number	Description
3946456 S	Mounting Bracket
2	No. of Brackets Required
3316659 S	Outlet Band Clamps
3946464 S	Weather Hood
3316609 S	Hump-Hose
3316569 S	90° Elbow
N/A	90° Reducing Elbow
3946326 S	Restriction Indicator

Service Parts	
Part Number	Description
AF26120	Primary Element
N/A	Magnum Primary Element
AF26121	Secondary Element
3946457 S	Dust Ejection Valve
3946463 S	Cover Assembly

Dimensions

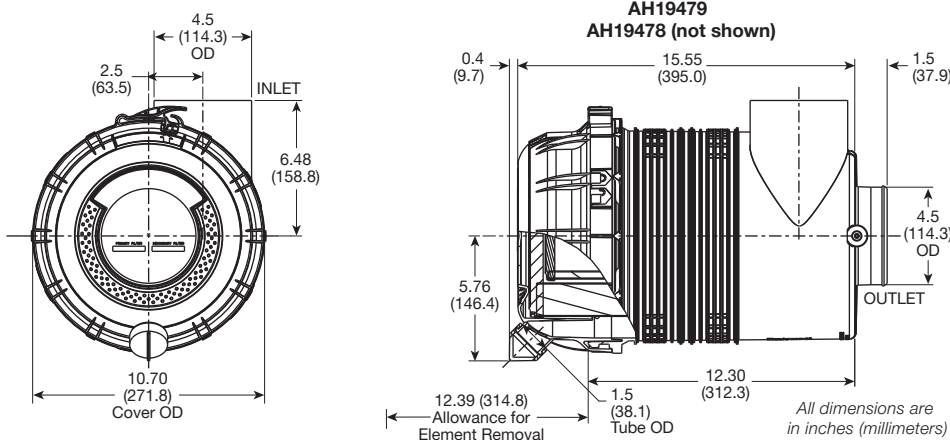

Performance

System Restriction vs Flow Rate

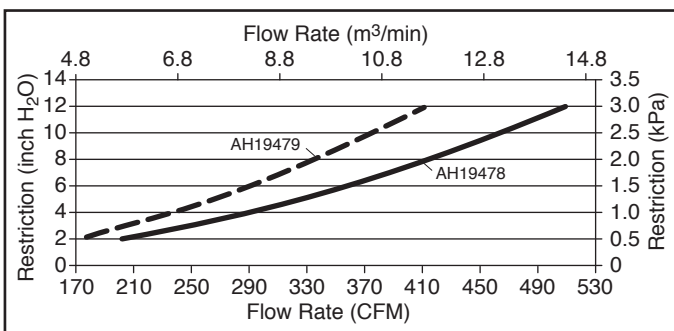

Typical System Capacity vs Flow Rate

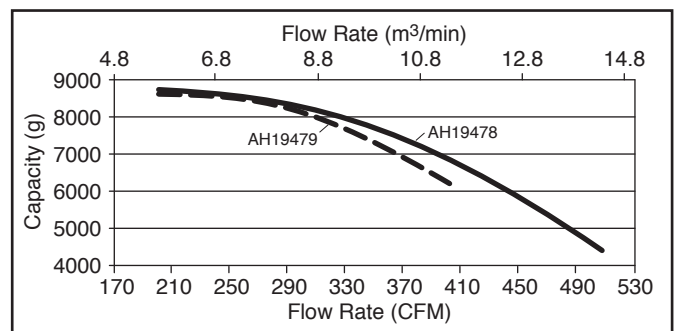

Restriction		Flow Rate () = with Secondary		Typical Capacity () = with Secondary
in H ₂ O	kPa	CFM	m ³ /min	grams
6	1.5	358 (289)	10.14 (8.18)	7670 (8248)
8	2.0	416 (336)	11.78 (9.52)	6590 (7546)
10	2.5	464 (375)	13.14 (10.62)	5535 (6805)
12	3.0	507 (411)	14.36 (11.64)	4400 (5990)

ISO Coarse Dust
2.0 g/m³ Feed Rate
6.25 kPa (25" H₂O) Terminal Restriction

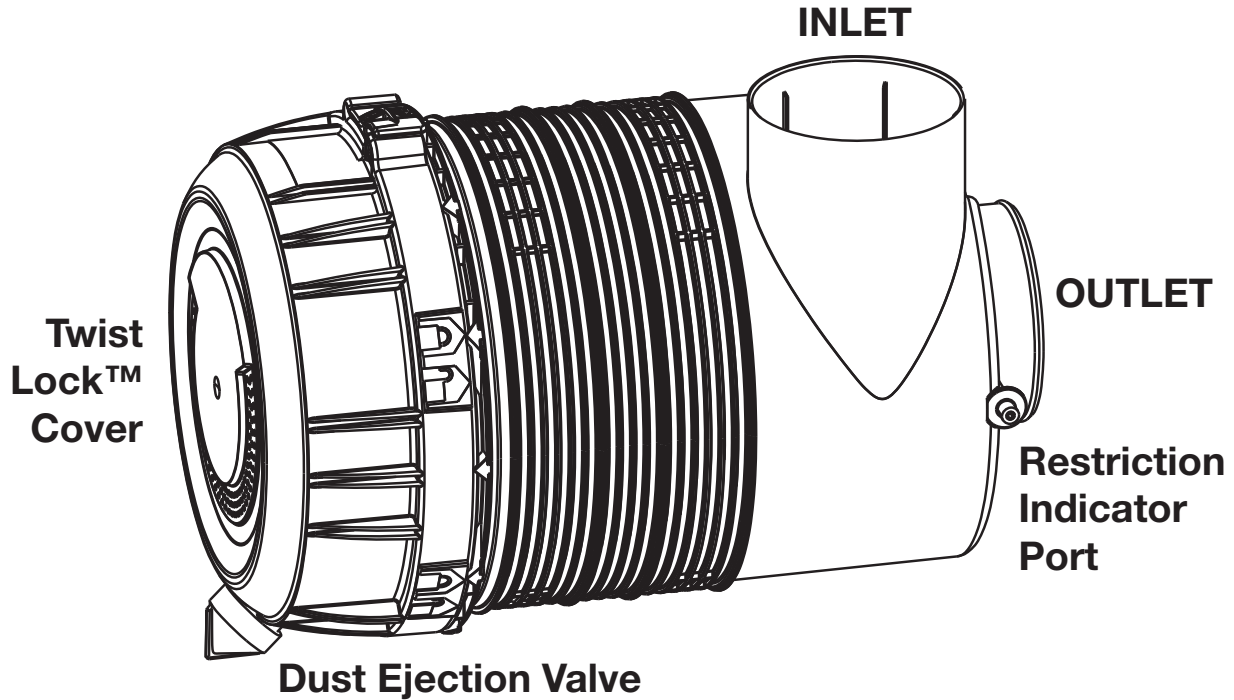

Specifications

Specification	AH19333	AH19334
Length Overall	19.2" (489.0 mm)	19.2" (489.0 mm)
Cover OD	12.2" (309.2 mm)	12.2" (309.2 mm)
Flow, Min. (2" restriction)	250 CFM (7.1 m ³ /min)	230 CFM (6.5 m ³ /min)
Flow, Max. (12" restriction)	663 CFM (18.8 m ³ /min)	544 CFM (15.4 m ³ /min)
Secondary Element	No	Yes
Housing Material	Glass-Filled Polypropylene	Glass-Filled Polypropylene
Pre-cleaner Integral	Yes	Yes
Outlet	Straight	Straight
Filter Efficiency	≥ 99.90% per ISO 5011	≥ 99.90% per ISO 5011

Dust Holding Capacity per Cummins® Specification

Specification	AH19333	AH19334
Allowable Flow for 10 g/CFM	< 663 CFM (18.8 m ³ /min)*	< 544 CFM (15.4 m ³ /min)*
Allowable Flow for 25 g/CFM	< 474 CFM (13.4 m ³ /min)	< 454 CFM (12.9 m ³ /min)

* Flow rate limited by restriction.

Specifications subject to change without notice.

Ordering Information

Air Cleaners	
Part Number	Description
AH19333	OptiAir™ 1100 Series Air Cleaner – without Secondary Element – with Straight Outlet
AH19334	OptiAir 1100 Series Air Cleaner – with Secondary Element – with Straight Outlet

Accessories	
Part Number	Description
3932495 S	Mounting Bracket
2	No. of Brackets Required
3316660 S	Outlet Band Clamps
3946466 S	Weather Hood
3316610 S	Hump-Hose
3316570 S	90° Elbow
N/A	90° Reducing Elbow
3946326 S	Restriction Indicator

Service Parts	
Part Number	Description
AF25962	Primary Element
N/A	Magnum Primary Element
AF25963	Secondary Element
3946457 S	Dust Ejection Valve
3946465 S	Cover Assembly

Dimensions

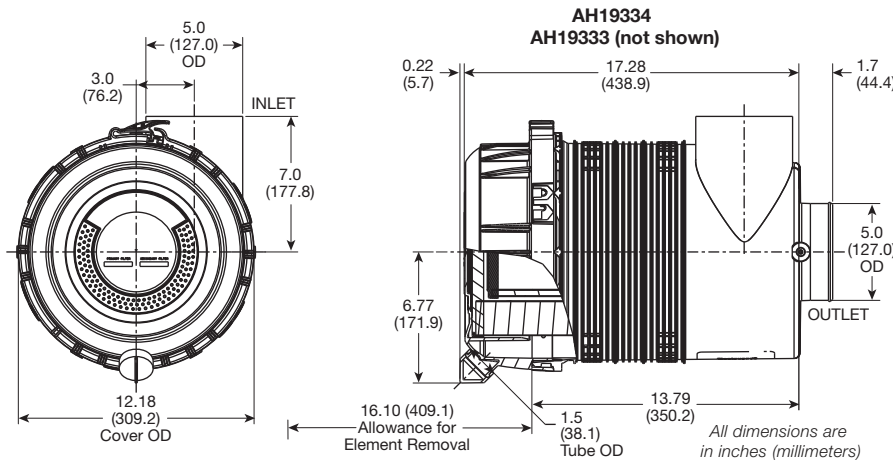

Performance

System Restriction vs Flow Rate

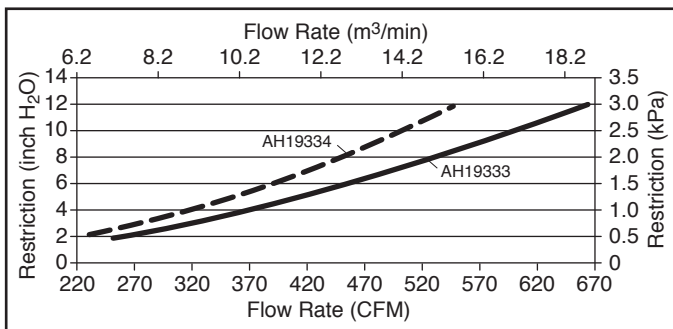

Typical System Capacity vs Flow Rate

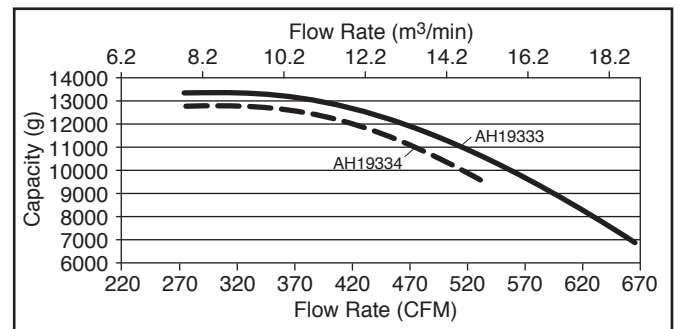

Restriction		Flow Rate () = with Secondary		Typical Capacity () = with Secondary
in H ₂ O	kPa	CFM	m ³ /min	grams
6	1.5	454 (390)	12.86 (11.04)	12230 (12300)
8	2.0	532 (451)	15.07 (12.77)	10700 (11580)
10	2.5	600 (510)	16.99 (14.44)	8951 (10162)
12	3.0	663 (544)	18.78 (15.41)	7000 (9200)

ISO Coarse Dust
2.0 g/m³ Feed Rate
6.25 kPa (25" H₂O) Terminal Restriction

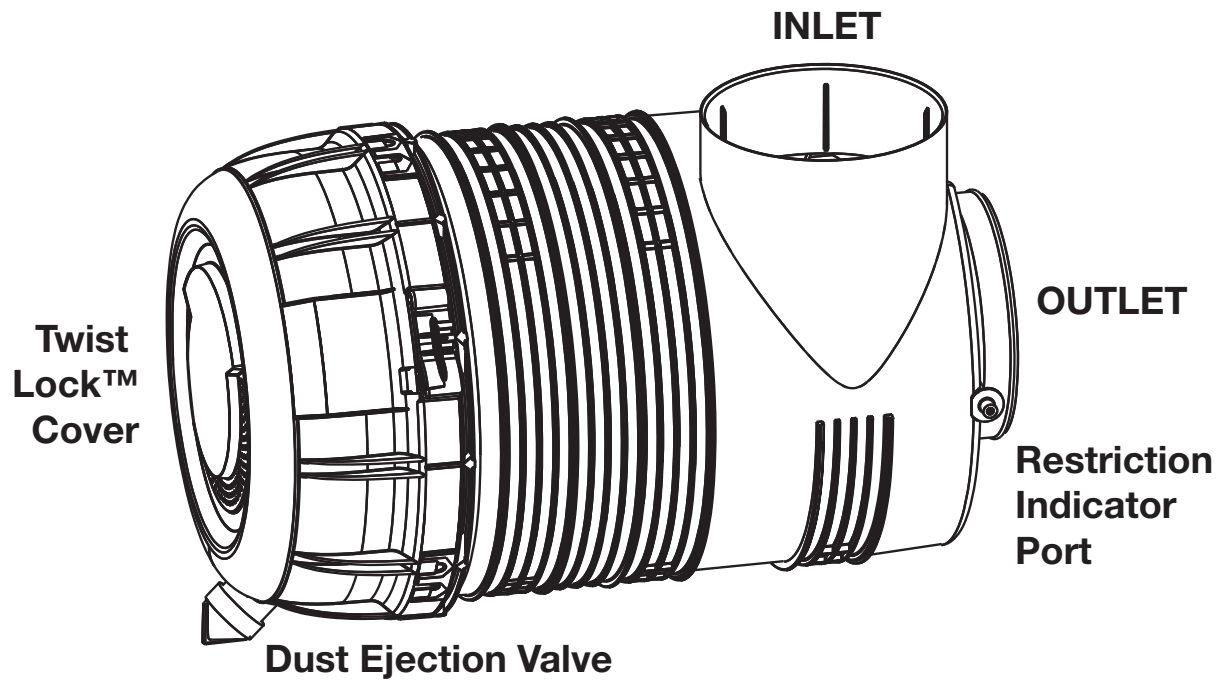

Specifications

Specification	AH19480	AH19481
Length Overall	23.0" (583.5 mm)	23.0" (583.5 mm)
Cover OD	14.0" (356.2 mm)	14.0" (356.2 mm)
Flow, Min. (2" restriction)	450 CFM (12.7 m ³ /min)	400 CFM (11.3 m ³ /min)
Flow, Max. (12" restriction)	1171 CFM (33.2 m ³ /min)	954 CFM (27.0 m ³ /min)
Secondary Element	No	Yes
Housing Material	Glass-Filled Polypropylene	Glass-Filled Polypropylene
Pre-cleaner Integral	Yes	Yes
Outlet	Straight	Straight
Filter Efficiency	≥ 99.90% per ISO 5011	≥ 99.90% per ISO 5011

Dust Holding Capacity per Cummins® Specification

Specification	AH19480	AH19481
Allowable Flow for 10 g/CFM	< 1134 CFM (32.1 m ³ /min)	< 954 CFM (27.0 m ³ /min)*
Allowable Flow for 25 g/CFM	< 705 CFM (20.0 m ³ /min)	< 673 CFM (19.1 m ³ /min)

* Flow rate limited by restriction.

Specifications subject to change without notice.

Ordering Information

Air Cleaners	
Part Number	Description
AH19480	OptiAir™ 1300 Series Air Cleaner – without Secondary Element – with Straight Outlet
AH19481	OptiAir 1300 Series Air Cleaner – with Secondary Element – with Straight Outlet

Accessories	
Part Number	Description
3936445 S	Mounting Bracket
2	No. of Brackets Required
3316663 S	Outlet Band Clamps
3946468 S	Weather Hood
3316613 S	Hump-Hose
3316576 S	90° Elbow
3316593 S	90° Reducing Elbow
3946326 S	Restriction Indicator

Service Parts	
Part Number	Description
AF26124	Primary Element
N/A	Magnum Primary Element
AF26125	Secondary Element
3946457 S	Dust Ejection Valve
3946467 S	Cover Assembly

Dimensions

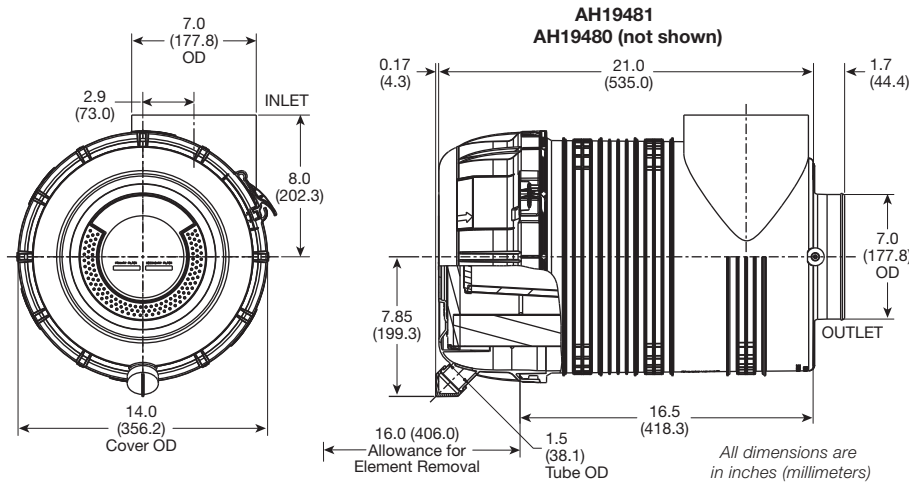

Performance

System Restriction vs Flow Rate

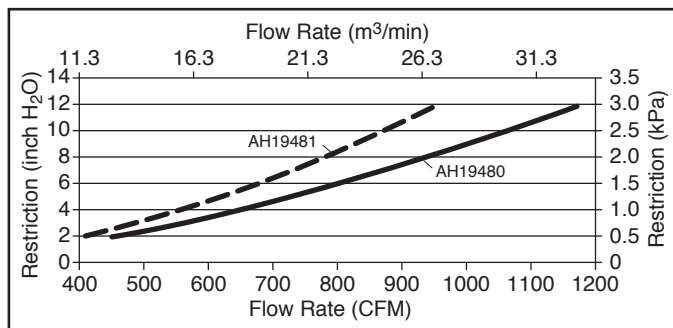

Typical System Capacity vs Flow Rate

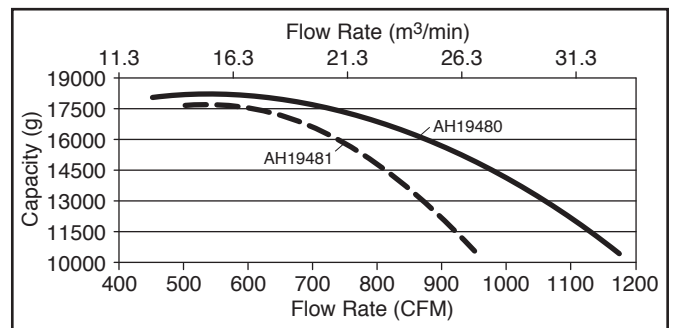

Restriction		Flow Rate () = with Secondary		Typical Capacity () = with Secondary
in H ₂ O	kPa	CFM	m ³ /min	grams
6	1.5	798 (676)	22.60 (19.14)	16862 (16789)
8	2.0	935 (779)	26.48 (22.06)	15129 (15110)
10	2.5	1058 (870)	29.96 (24.64)	12965 (12950)
12	3.0	1171 (953)	33.16 (26.99)	10482 (10442)

ISO Coarse Dust
2.0 g/m³ Feed Rate
6.25 kPa (25" H₂O) Terminal Restriction

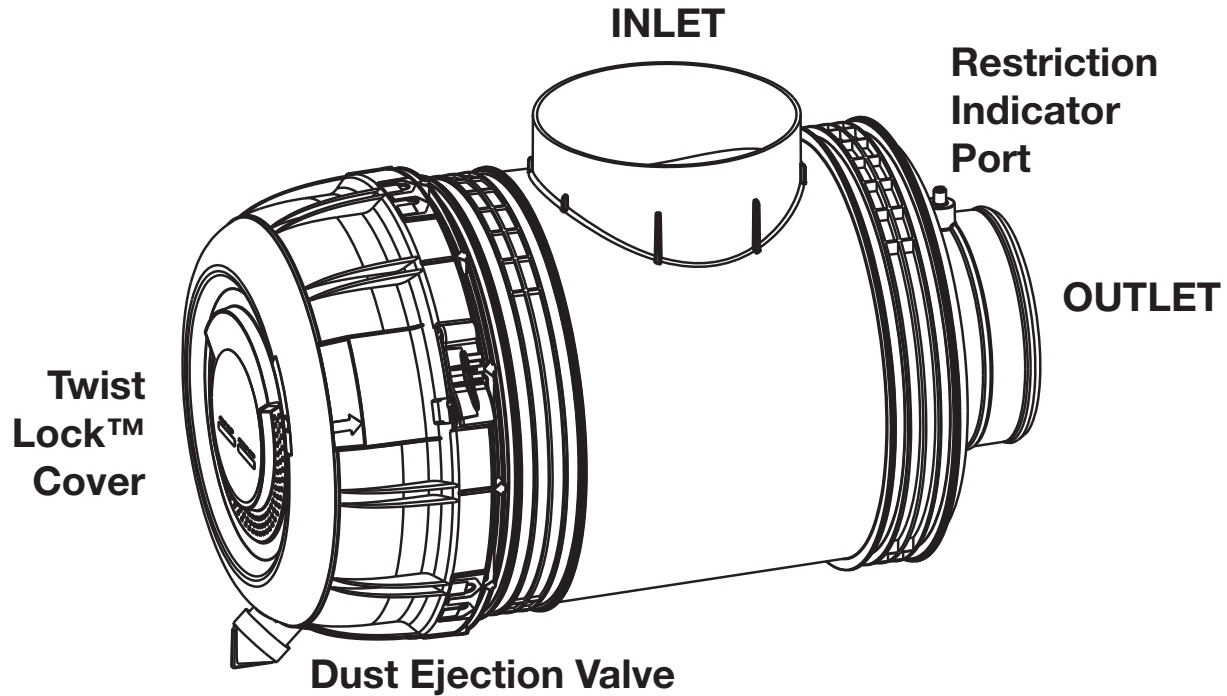

Specifications

Specification	AH19274
Length Overall	23.8" (603.7 mm)
Cover OD	14.1" (358.1 mm)
Flow, Min. (2" restriction)	612 CFM (17.3 m ³ /min)
Flow, Max. (12" restriction)	1503 CFM (42.6 m ³ /min)
Secondary Element	No
Housing Material	Plastic
Pre-cleaner Integral	No
Outlet	Straight
Filter Efficiency	≥ 99.90% per ISO 5011

Dust Holding Capacity per Cummins® Specification

Specification	AH19274
Allowable Flow for 3 g/CFM	< 1263 CFM (35.8 m ³ /min)
Allowable Flow for 10 g/CFM	< 682 CFM (19.4 m ³ /min)
Allowable Flow for 25 g/CFM	< 338 CFM (9.6 m ³ /min)

Specifications subject to change without notice.

Ordering Information

Air Cleaners	
Part Number	Description
AH19274	OptiAir™ 1300 Series Air Cleaner – without Secondary Element – with Straight Outlet

Accessories	
Part Number	Description
3936445 S	Mounting Bracket
2	No. of Brackets Required
3316663 S	Outlet Band Clamps
3918213 S	Weather Hood
3316613 S	Hump-Hose
3316576 S	90° Elbow
3316591 S	90° Reducing Elbow
3946326 S	Restriction Indicator

Service Parts	
Part Number	Description
AF25708	Primary Element
AF25708M	Magnum Primary Element
3946457 S	Dust Ejection Valve
Q760517	Cover Assembly

Dimensions

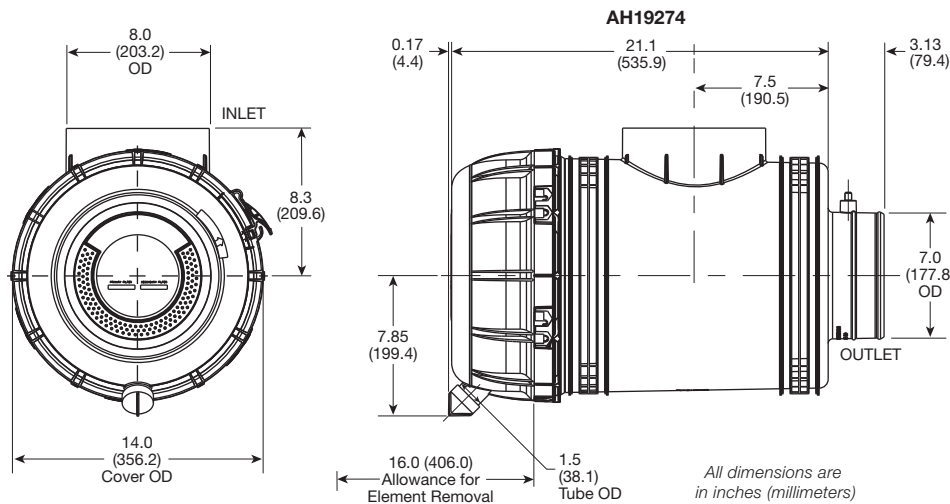

Performance

System Restriction vs Flow Rate

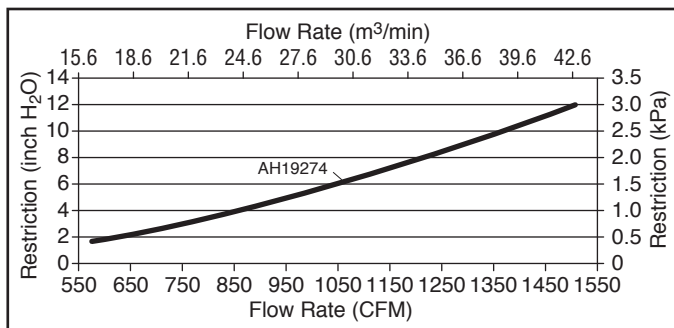

Typical System Capacity vs Flow Rate

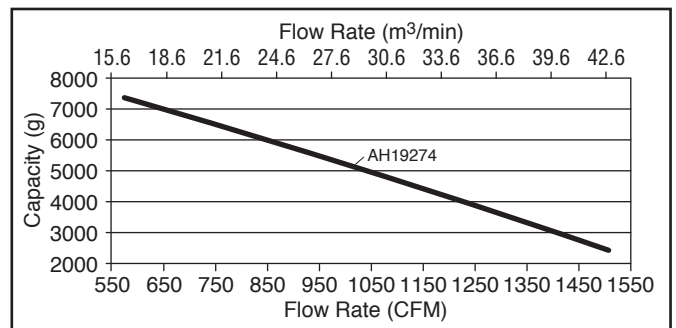

Restriction		Flow Rate () = with Secondary		Typical Capacity () = with Secondary
in H ₂ O	kPa	CFM	m³/min	grams
6	1.5	1047	29.65	4956
8	2.0	1215	34.41	4055
10	2.5	1366	38.66	3227
12	3.0	1503	42.56	2452

ISO Coarse Dust
2.0 g/m³ Feed Rate
6.25 kPa (25" H₂O) Terminal Restriction

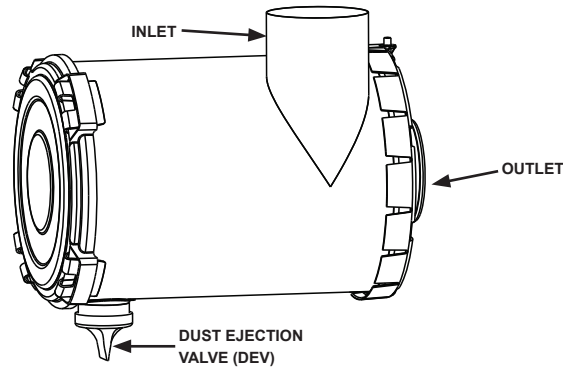

Specifications

Specification	AH08787	AH08788
Length, Overall	22.6" (575.3 mm)	22.6" (575.3 mm)
Width, Overall	15.0" (380.7 mm)	15.0" (380.7 mm)
Height, Overall	20.6" (523.2 mm)	20.6" (523.2 mm)
Flow, Max. (12" restriction)	1074 cfm (30.4 m ³ /min)	1036 cfm (29.3 m ³ /min)
Flow, Min. (2" restriction)	425 cfm (12.0 m ³ /min)	306 cfm (8.7 m ³ /min)
Secondary Element	No	Yes
Housing Material	Metal	Metal
Cover Material	Plastic	Plastic
Pre-cleaner Integral	Yes	Yes
Inlet	Straight 6" (152.4 mm)	Straight 6" (152.4 mm)
Outlet	Straight 6" (152.4 mm)	Straight 6" (152.4 mm)
Filter Efficiency	≥ 99.90% per ISO 5011	≥ 99.90% per ISO 5011

Specifications subject to change without notice.

Dust Holding Capacity per Flow Rate

Specification	AH08787	AH08788
Maximum Flow for 10 g/cfm	<1108 cfm (31.4 m ³ /min)	<1070 cfm (30.3 m ³ /min)
Maximum Flow for 25 g/cfm	< 637 cfm (18.0 m ³ /min)	< 596 cfm (16.9 m ³ /min)

Dimensions

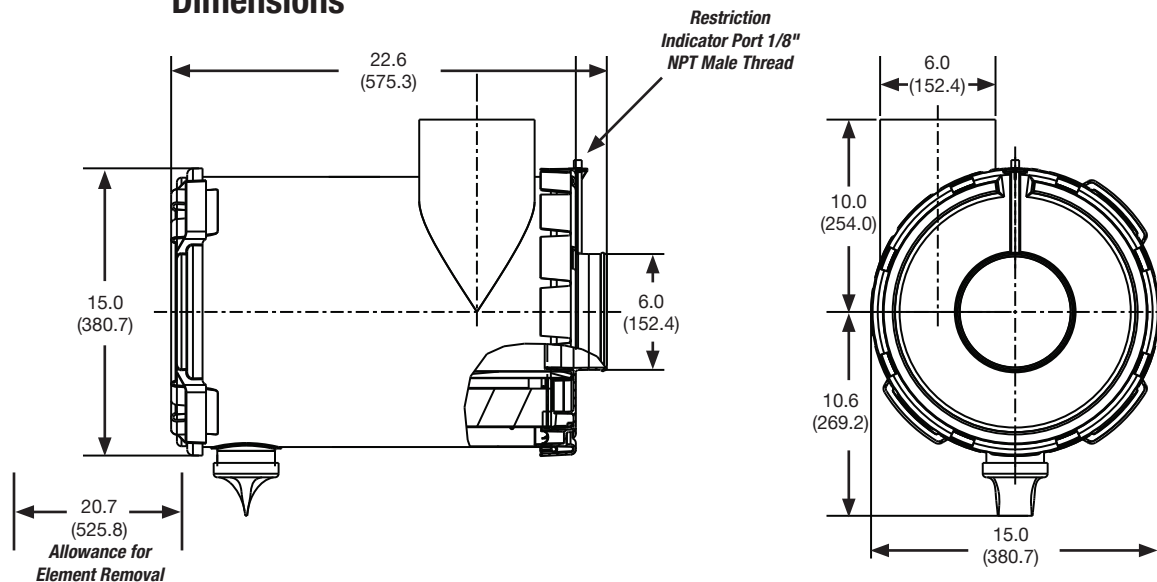

Ordering Information

Pre-Cleaner	
Part Number	Description
AH08787	14" Hybrid OptiAir™ -without Secondary Element
AH08788	14" Hybrid OptiAir™ -with Secondary Element

Service Parts	
Part Number	Description
AF26359	Primary Element
AF26360	Secondary Element
3947069S	Dust Ejection Valve
Q761248	Cover Assembly

Optional Accessories	
Part Number	Description
3918234S	Mounting Brackets (2) Required
3316662S	Outlet Band Clamps
3949015S	Weather Hood
3316612S	Hump-Hose
3316573S	90° Elbow
3316589S	Reducing Elbow
3946326S	Restriction Indicator

Additional sizes/shapes may be available.
Refer to the Cummins Filtration catalog or website.

Performance

System Restriction vs Flow Rate

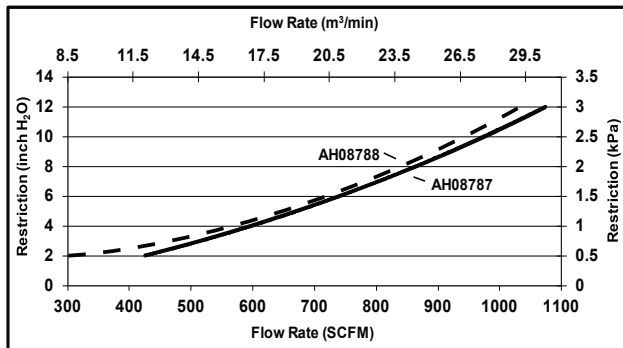

System Capacity vs Flow Rate

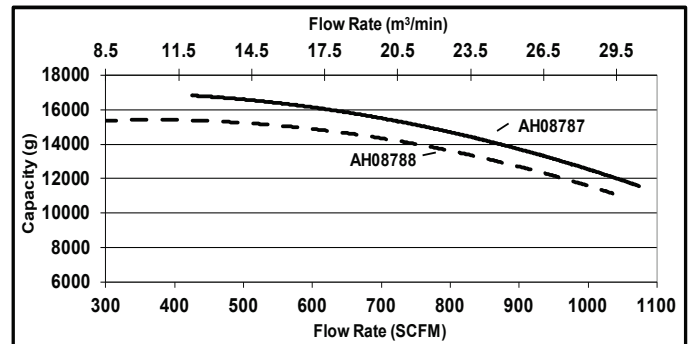

Restriction		Flow Rate () = with Secondary		Typical Capacity at 25" of H ₂ O (6.2 kPa) of Terminal Restriction (grams)
in H ₂ O	kPa	CFM	m³/min	
4	1.0	599 (568)	16.96 (16.09)	16141 (14583)
6	1.5	741 (722)	20.99 (20.45)	15191 (14349)
8	2.0	864 (842)	24.47 (23.85)	14082 (13502)
10	2.5	974 (945)	27.58 (26.76)	12863 (12320)
12	3.0	1074 (1036)	30.42 (29.34)	11565 (10920)

ISO Coarse Dust
2.0 g/m³ Feed Rate
25" of H₂O (6.2 kPa)
Terminal Restriction
per ISO 5011

How to Service an OptiAir™ System OptiAir™ Air Cleaners



1 Time for an element change...
The restriction indicator mounted on your OptiAir™ system indicates when your OptiAir element needs changing.



2 Lift the lever as indicated on the OptiAir cover label.



3 Twist the OptiAir cover to the left into the "open" position.



4 Remove the OptiAir cover.



5 Twist the end of the filter to disengage seal. Gently remove the filter element¹ from the housing. Inspect the filter for foreign material on the sealing surface and potential marks of dust on the clean air side.

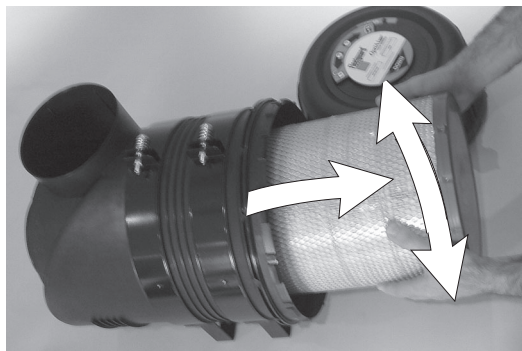

¹ If servicing a system that contains a secondary element that needs to be replaced, apply the same procedure as shown in step 5.

OptiAir™ Air Cleaners How to Service an OptiAir™ System

- 6** Thoroughly clean the sealing surface and the inside of the OptiAir™ housing.

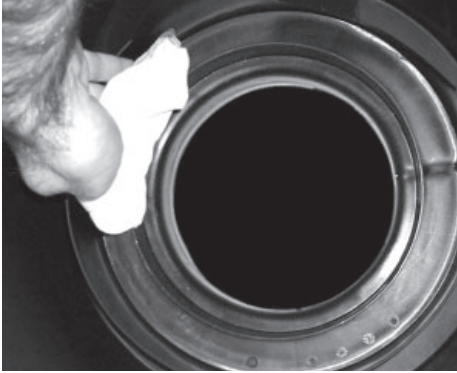

- 7** Inspect the new filter element² for damage and insert into the housing.

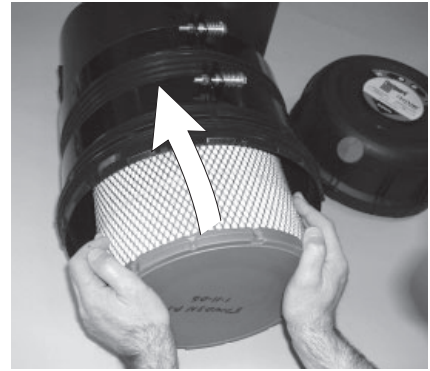

- 8** Place the OptiAir cover back on the housing. Make sure dust ejection valve is orientated downward.



- 9** Twist the OptiAir cover to the right into the “locked” position

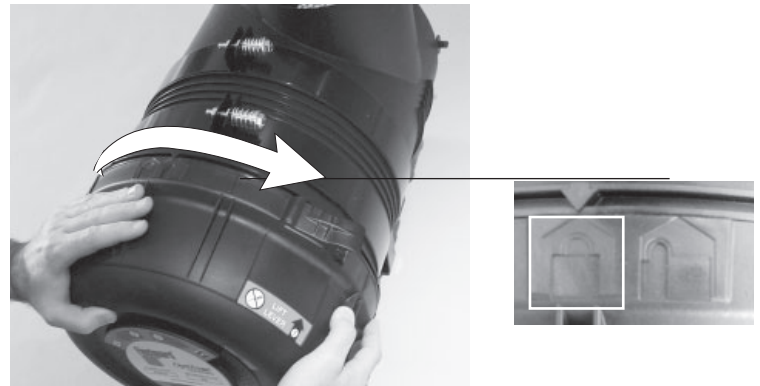

- 10** Reset the restriction indicator.

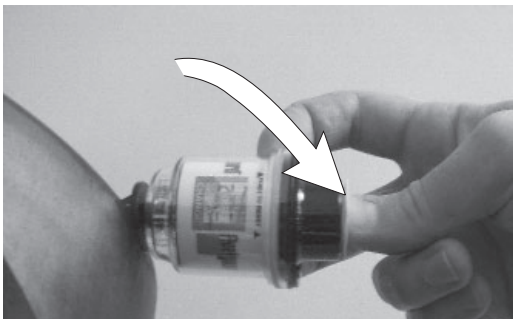

² If servicing a system that contains a secondary element that needs to be replaced, apply the same procedure as shown in step 7.

Metal Air Cleaners

**Medium Dust Applications
Integral Pre-Cleaner
Primary Element Only**

Part Number	CFM @ 10" H ₂ O	m ³ /min @ 2.5 kPa
AH19107	70	1.98
AH19108	103	2.92
AH19109	167	4.73
AH19110	244	6.91
AH19061	134	3.79
AH19063	170	4.81
AH19065	301	8.52
AH19268	287	8.13
AH19270	410	11.61
AH19069	574	16.26
AH19271	692	19.60
AH19073	1131	32.03
AH19075	1650	46.73

**Light Dust Applications
Primary Element Only**

Part Number	CFM @ 6" H ₂ O	m ³ /min @ 1.5 kPa
AH19077	331	9.37
AH19078	555	15.72
AH19079	805	22.80
AH19080	825	23.36

**Heavy or Medium Dust Applications
Integral Pre-Cleaner
Primary and Secondary Element**

Part Number	CFM @ 10" H ₂ O	m ³ /min @ 2.5 kPa
AH19062	114	3.23
AH19064	153	4.33
AH19066	251	7.11
AH19269	345	9.77
AH19070	406	11.50
AH19272	625	17.70
AH19259	821	23.25
AH19074	1098	31.10
AH19076	1600	45.31

Style 1

- AH19107 AH19061
- AH19108 AH19063
- AH19109 AH19065
- AH19110 AH19069

	Part
A	O-Ring
B	Wing Nut
C	Element
D	Wing Nut
E	Dust Ejector
F	Cover Assembly

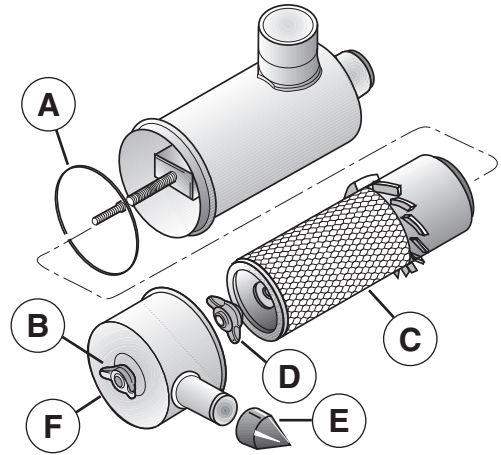

Style 2

- AH19062
- AH19064
- AH19066
- AH19268
- AH19070

	Part
A	O-Ring
B	Wing Nut
C	Element
D	Wing Nut
E	Dust Ejector
F	Cover Assembly
G	Secondary Element
H	Wing Nut

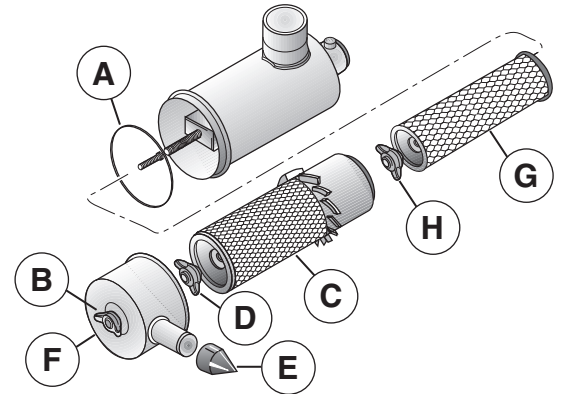

Style 3

- AH19073 AH19259
- AH19074 AH19269
- AH19075 AH19270
- AH19076 AH19271
- AH19077 AH19272
- AH19078
- AH19079
- AH19080

	Part
A	Wing Nut
B	Element
C	Wing Nut
D	Dust Ejector
E	Secondary Element

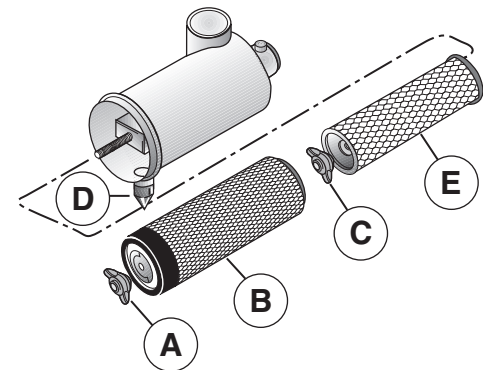

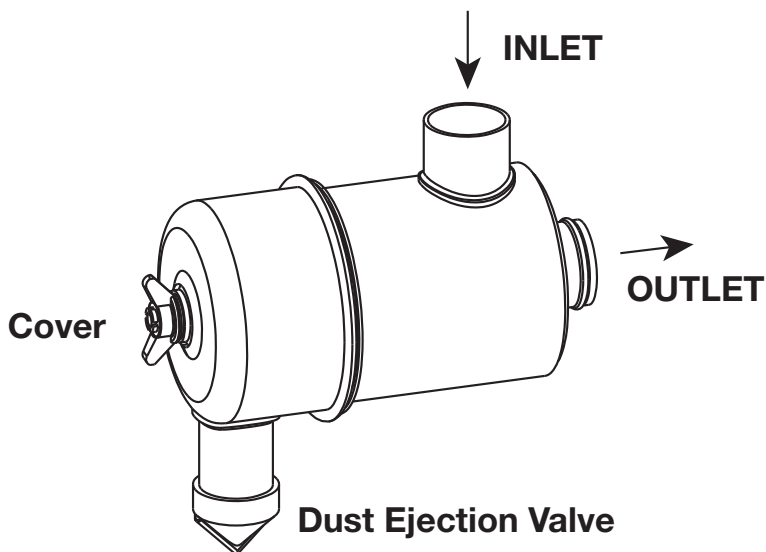

Specifications

Specification	AH19107
Length Overall	8.5" (216.0 mm)
Body OD	4.38" (111.3 mm)
Flow, Min. (2" Restriction)	31 CFM (0.9 m ³ /min)
Flow, Max. (12" Restriction)	76 CFM (2.2 m ³ /min)
Secondary Element	No
Housing Material	Metal
Pre-cleaner Integral	Yes
Filter Efficiency	≥ 99.90% per ISO 5011

Dust Holding Capacity per Cummins® Specification

Specification	AH19107
Allowable Flow for 3 g/CFM	< 75 CFM (2.1 m ³ /min)
Allowable Flow for 10 g/CFM	< 58 CFM (1.6 m ³ /min)
Allowable Flow for 25 g/CFM	< 40 CFM (1.1 m ³ /min)

Specifications subject to change without notice.

Ordering Information

Air Cleaner	
Part Number	Description
AH19107	Metal Air Cleaner

Accessories	
Part Number	Description
3918218 S	Mounting Bracket
1	No. of Brackets Required
N/A	Outlet Band Clamps
3918195S	Weather Hood
N/A	Hump-Hose
N/A	90° Elbow
N/A	90° Reducing Elbow
N/A	Restriction Indicator

Service Parts	
Part Number	Description
AF1658K	Primary Element
N/A	Magnum Primary Element
N/A	Secondary Element
3946457S	Dust Ejection Valve
3955486S	Wing Nut/Clips
3955491S	Wing Nut/Clips
3955467S	Cover Assembly

Dimensions

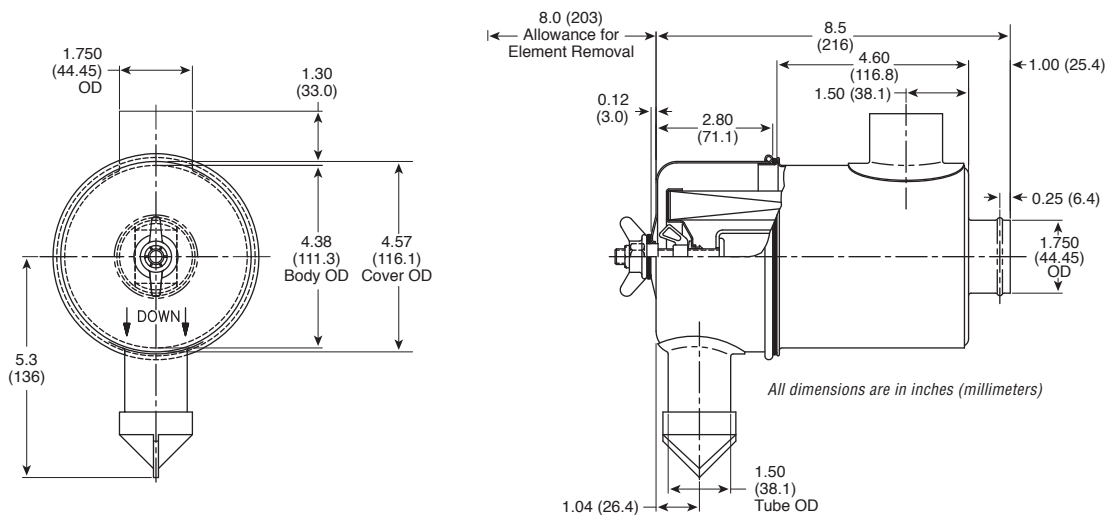

Performance

System Restriction vs Flow Rate

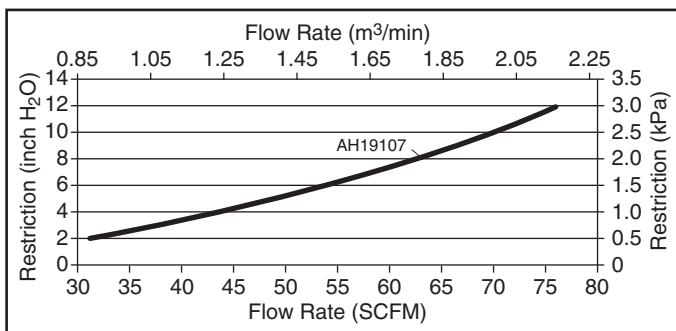

Typical System Capacity vs Flow Rate

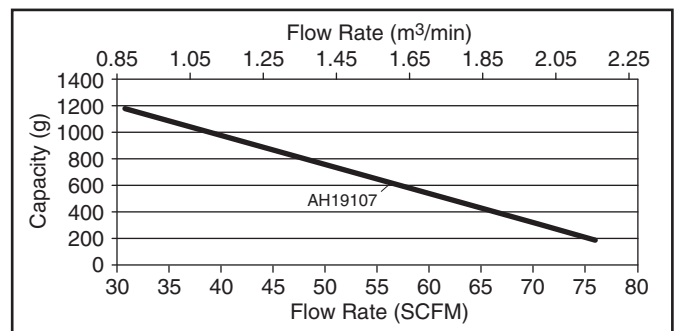

Restriction		Flow Rate		Typical Capacity
in H ₂ O	kPa	CFM	m³/min	grams
6	1.5	54	1.53	680
8	2.0	62	1.76	495
10	2.5	70	1.98	332
12	3.0	76	2.15	184

ISO Coarse Dust
 2.0 g/m³ Feed Rate
 6.25 kPa (25" H₂O) Terminal Restriction



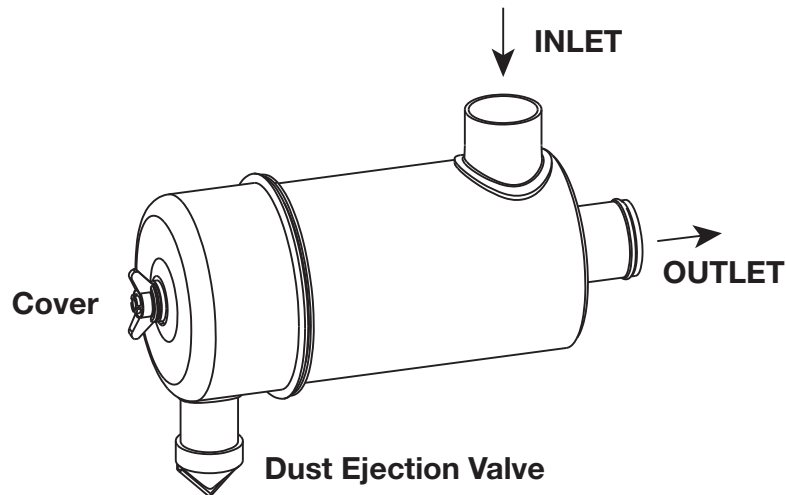

Specifications

Specification	AH19108
Length Overall	12.9" (326.4 mm)
Body OD	5.3" (133.4 mm)
Flow, Min. (2" Restriction)	44 CFM (1.3 m ³ /min)
Flow, Max. (12" Restriction)	113 CFM (3.2 m ³ /min)
Secondary Element	No
Housing Material	Metal
Pre-cleaner Integral	Yes
Filter Efficiency	≥ 99.90% per ISO 5011

Dust Holding Capacity per Cummins® Specification

Specification	AH19108
Allowable Flow for 10 g/CFM	< 96 CFM (2.7 m ³ /min)
Allowable Flow for 25 g/CFM	< 68 CFM (1.9 m ³ /min)

Specifications subject to change without notice.

Ordering Information

Air Cleaner	
Part Number	Description
AH19108	Metal Air Cleaner

Accessories	
Part Number	Description
39183219S	Mounting Bracket
2	No. of Brackets Required
3316653S	Outlet Band Clamps
3918200S	Weather Hood
N/A	Hump-Hose
3316564S	90° Elbow
N/A	90° Reducing Elbow
N/A	Restriction Indicator

Service Parts	
Part Number	Description
AF25543K	Primary Element
N/A	Magnum Primary Element
N/A	Secondary Element
3946457S	Dust Ejection Valve
3955488S 3955489S	Wing Nut/Clips
3955472S	Cover Assembly

Dimensions

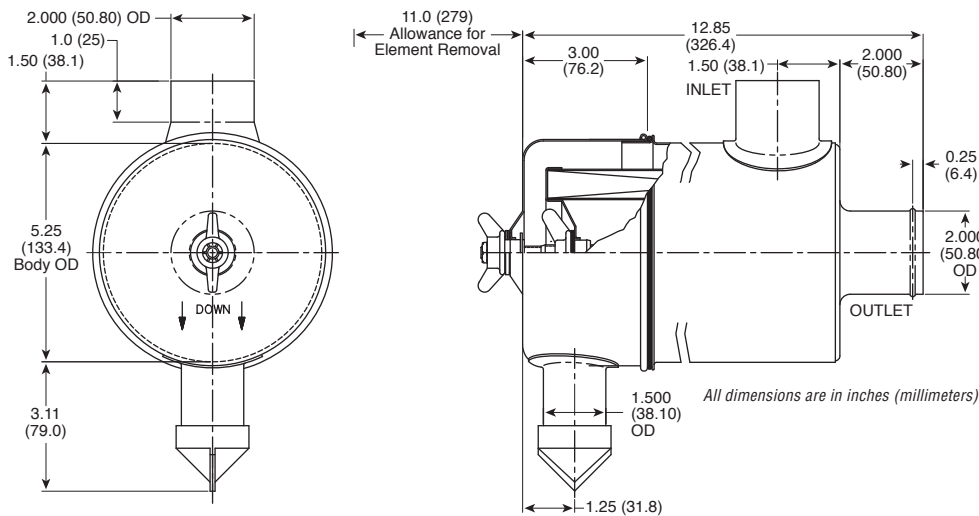

Performance

System Restriction vs Flow Rate

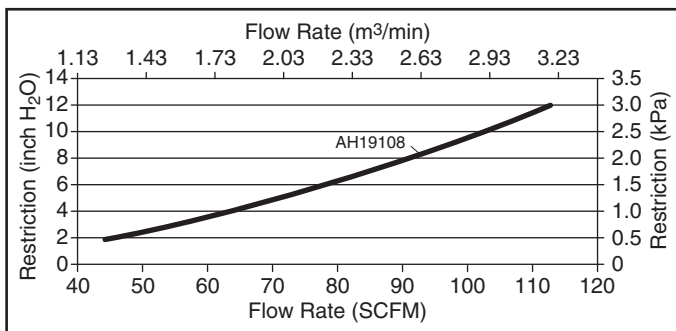

Typical System Capacity vs Flow Rate

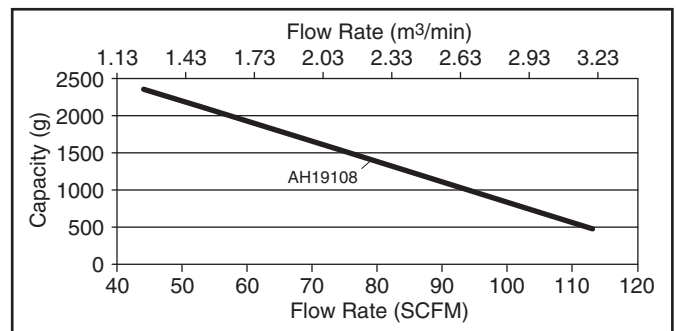

Restriction		Flow Rate		Typical Capacity
in H ₂ O	kPa	CFM	m³/min	grams
6	1.5	78	2.21	1434
8	2.0	91	2.58	1088
10	2.5	103	2.92	770
12	3.0	113	3.20	484

ISO Coarse Dust
2.0 g/m³ Feed Rate
6.25 kPa (25" H₂O) Terminal Restriction



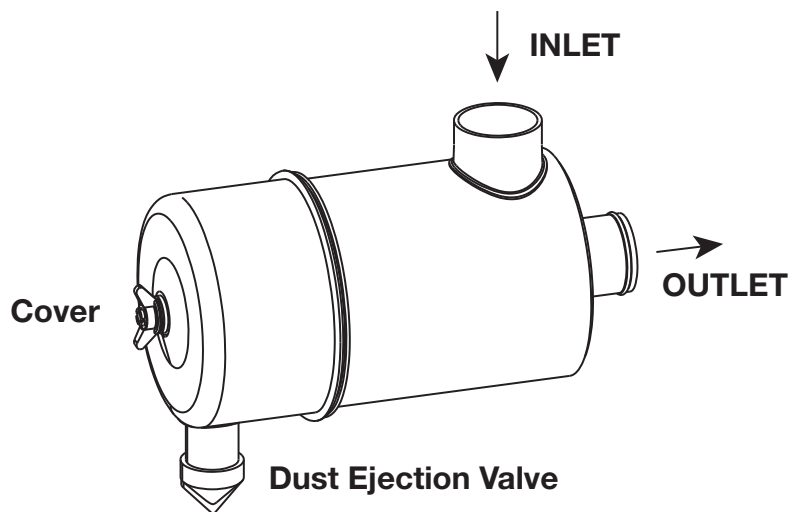

Specifications

Specification	AH19109
Length Overall	13.7" (346.7 mm)
Body OD	6.6" (166.4 mm)
Flow, Min. (2" Restriction)	71 CFM (2.0 m ³ /min)
Flow, Max. (12" Restriction)	184 CFM (5.2 m ³ /min)
Secondary Element	No
Housing Material	Metal
Pre-cleaner Integral	Yes
Filter Efficiency	≥ 99.90% per ISO 5011

Dust Holding Capacity per Cummins® Specification

Specification	AH19109
Allowable Flow for 3 g/CFM	< 180 CFM (5.1 m ³ /min)
Allowable Flow for 10 g/CFM	< 145 CFM (4.1 m ³ /min)
Allowable Flow for 25 g/CFM	< 103 CFM (2.9 m ³ /min)

Specifications subject to change without notice.

Ordering Information

Air Cleaner	
Part Number	Description
AH19109	Metal Air Cleaner

Accessories	
Part Number	Description
3918220S	Mounting Bracket
2	No. of Brackets Required
3316653S	Outlet Band Clamps
3918201S	Weather Hood
N/A	Hump-Hose
N/A	90° Elbow
N/A	90° Reducing Elbow
N/A	Restriction Indicator

Service Parts	
Part Number	Description
AF437K	Primary Element
AF437KM	Magnum Primary Element
N/A	Secondary Element
3946457S	Dust Ejection Valve
3955488S 3955489S	Wing Nut/Clips
3955470S	Cover Assembly

Dimensions

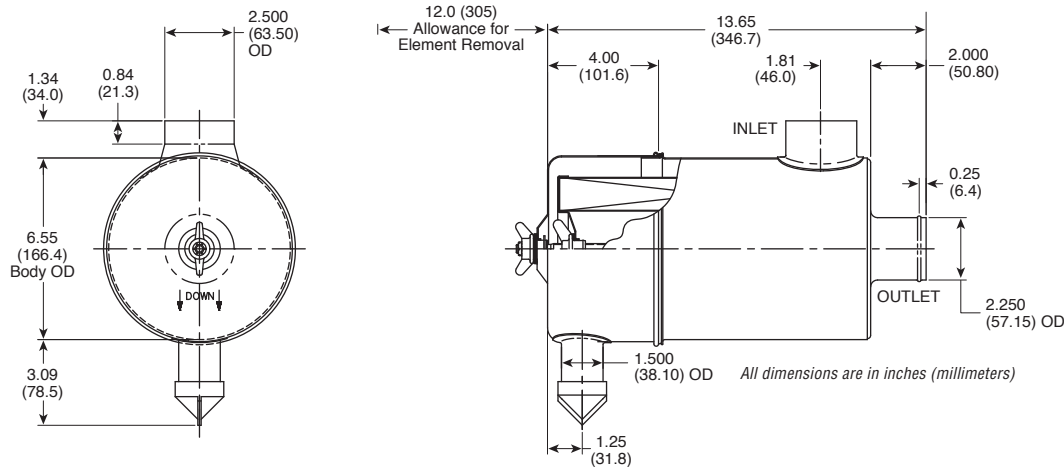

Performance

System Restriction vs Flow Rate

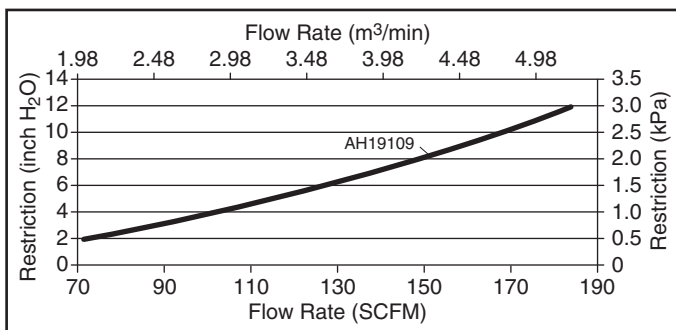

Typical System Capacity vs Flow Rate

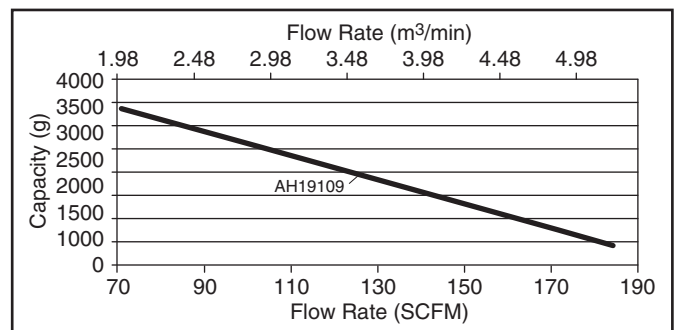

Restriction		Flow Rate		Typical Capacity
in H ₂ O	kPa	CFM	m³/min	grams
6	1.5	127	3.60	1918
8	2.0	148	4.19	1369
10	2.5	167	4.73	881
12	3.0	184	5.21	438

ISO Coarse Dust
2.0 g/m³ Feed Rate
6.25 kPa (25" H₂O) Terminal Restriction



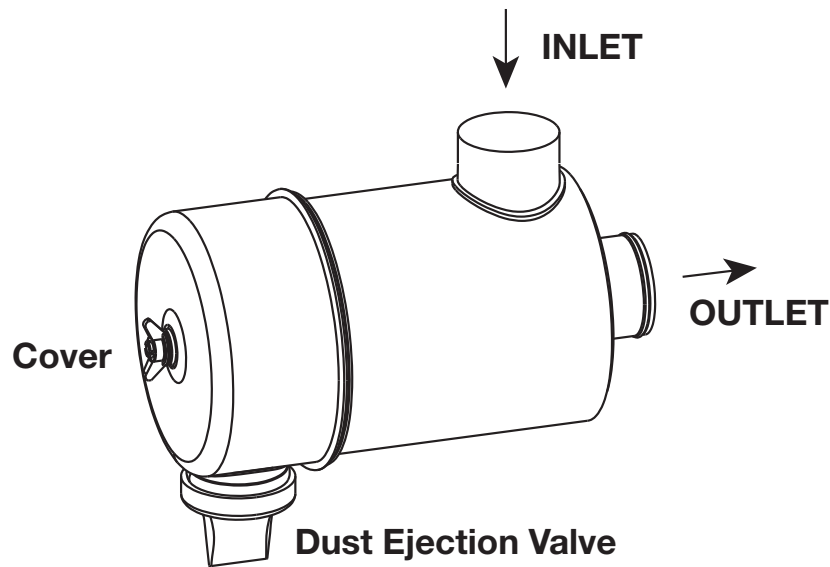

Specifications

Specification	AH19110
Length Overall	14.5" (369.6 mm)
Body OD	7.9" (200.4 mm)
Flow, Min. (2" Restriction)	108 CFM (3.1 m ³ /min)
Flow, Max. (12" Restriction)	267 CFM (7.6 m ³ /min)
Secondary Element	No
Housing Material	Metal
Pre-cleaner Integral	Yes
Filter Efficiency	≥ 99.90% per ISO 5011

Dust Holding Capacity per Cummins® Specification

Specification	AH19110
Allowable Flow for 10 g/CFM	< 246 CFM (7.0 m ³ /min)
Allowable Flow for 25 g/CFM	< 165 CFM (4.7 m ³ /min)

Specifications subject to change without notice.

Ordering Information

Air Cleaner	
Part Number	Description
AH19110	Metal Air Cleaner

Accessories	
Part Number	Description
3918222S	Mounting Bracket
2	No. of Brackets Required
3316656S	Outlet Band Clamps
3918202S	Weather Hood
3316606S	Hump-Hose
3316566S	90° Elbow
N/A	90° Reducing Elbow
N/A	Restriction Indicator

Service Parts	
Part Number	Description
AF409K	Primary Element
AF409KM	Magnum Primary Element
N/A	Secondary Element
Q06316	Dust Ejection Valve
3955488S 3955489S	Wing Nut/Clips
3955469S	Cover Assembly

Dimensions

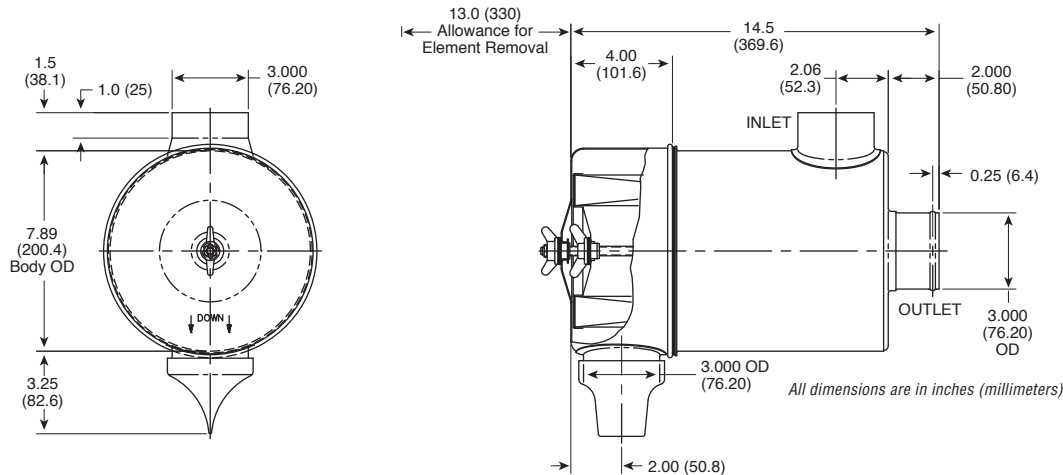

Performance

System Restriction vs Flow Rate

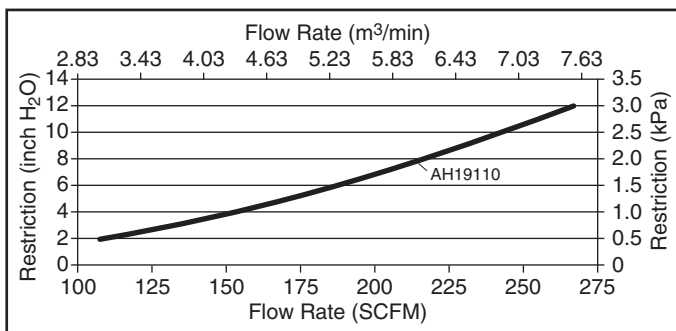

Typical System Capacity vs Flow Rate

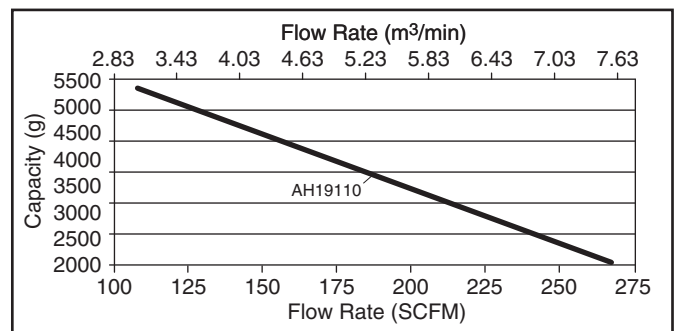

Restriction		Flow Rate		Typical Capacity
in H ₂ O	kPa	CFM	m ³ /min	grams
6	1.5	188	5.32	3664
8	2.0	218	6.17	3055
10	2.5	244	6.91	2518
12	3.0	267	7.56	2031

ISO Coarse Dust
2.0 g/m³ Feed Rate
6.25 kPa (25" H₂O) Terminal Restriction



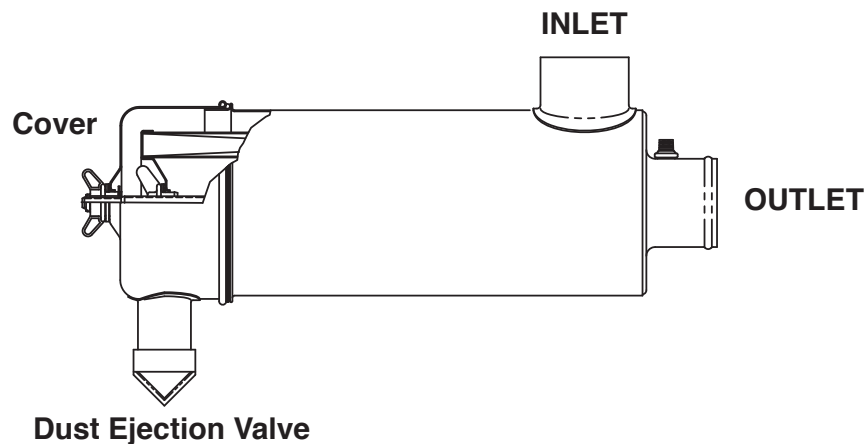

Specifications

Specification	AH19061	AH19062
Length Overall	16.9" (429.0 mm)	16.9" (429.0 mm)
Body OD, Max.	5.3" (200.4 mm)	5.3" (200.4 mm)
Flow, Min. (2" Restriction)	58 CFM (1.6 m ³ /min)	48 CFM (1.4 m ³ /min)
Flow, Max. (12" Restriction)	147 CFM (4.2 m ³ /min)	125 CFM (35 m ³ /min)
Secondary Element	No	Yes
Housing Material	Metal	Metal
Pre-cleaner Integral	Yes	Yes
Filter Efficiency	≥ 99.90% per ISO 5011	≥ 99.90% per ISO 5011

Dust Holding Capacity per Cummins® Specification

Specification	AH19061	AH19062
Allowable Flow for 10 g/CFM	< 123 CFM (3.5 m ³ /min)	< 102 CFM (2.9 m ³ /min)
Allowable Flow for 25 g/CFM	< 85 CFM (2.4 m ³ /min)	< 72 CFM (2.0 m ³ /min)

Specifications subject to change without notice.

Ordering Information

Air Cleaners	
Part Number	Description
AH19061	Metal Air Cleaner – without Secondary Element
AH19062	Metal Air Cleaner – with Secondary Element

Accessories	
Part Number	Description
3918219 S	Mounting Bracket
2	No. of Brackets Required
3316654 S	Outlet Band Clamps
3918201 S	Weather Hood
N/A	Hump-Hose
3316565 S	90° Elbow
N/A	90° Reducing Elbow
3946326 S	Restriction Indicator

Service Parts	
Part Number	Description
AF1823K	Primary Element
N/A	Magnum Primary Element
AF26118	Secondary Element
3946457S	Dust Ejection Valve
3955488S 3955489S	Wing Nut/Clips
3955468S	Cover Assembly

Dimensions

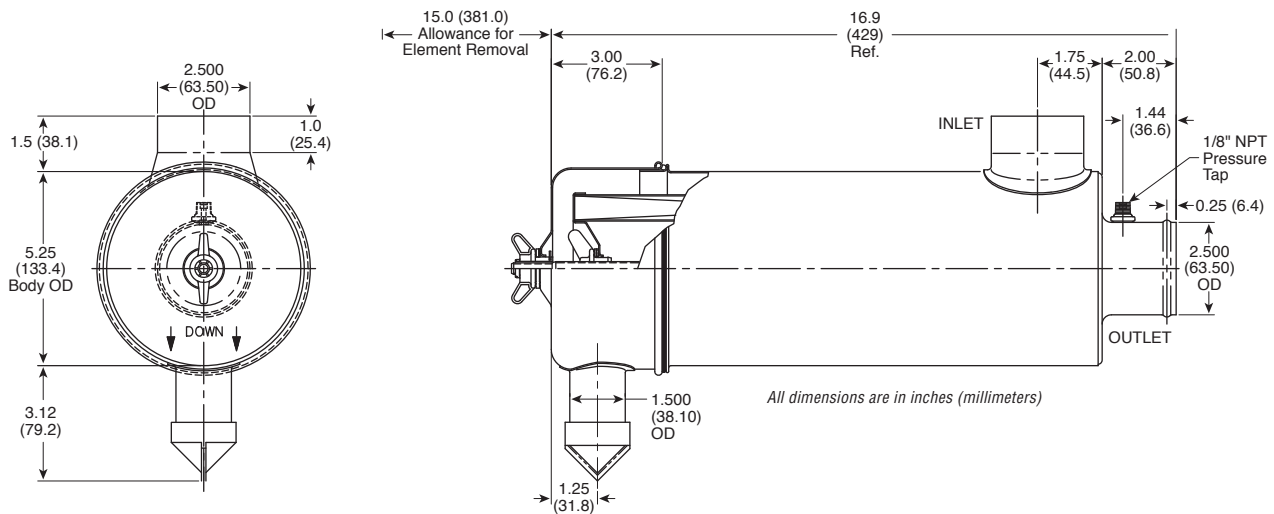

Performance

System Restriction vs Flow Rate

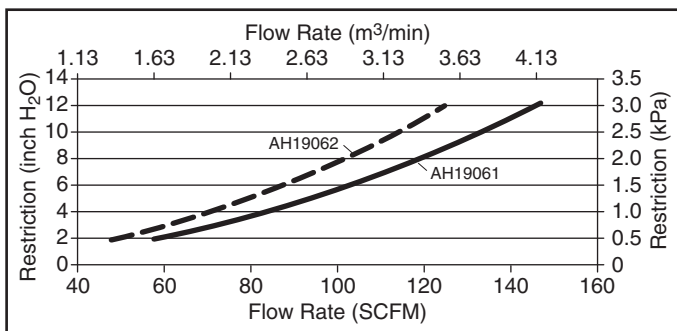

Typical System Capacity vs Flow Rate

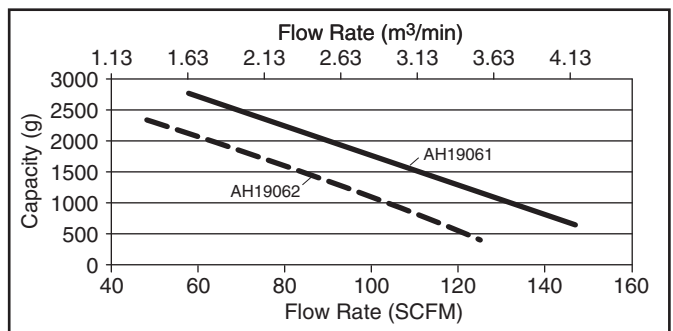

Restriction		Flow Rate () = with Secondary		Typical Capacity () = with Secondary
in H ₂ O	kPa	CFM	m ³ /min	grams
6	1.5	103 (88)	2.92 (2.49)	1691 (1390)
8	2.0	119 (102)	3.37 (2.89)	1307 (1029)
10	2.5	134 (114)	3.79 (3.23)	969 (699)
12	3.0	147 (125)	4.16 (3.54)	662 (391)

ISO Coarse Dust
2.0 g/m³ Feed Rate
6.25 kPa (25" H₂O) Terminal Restriction



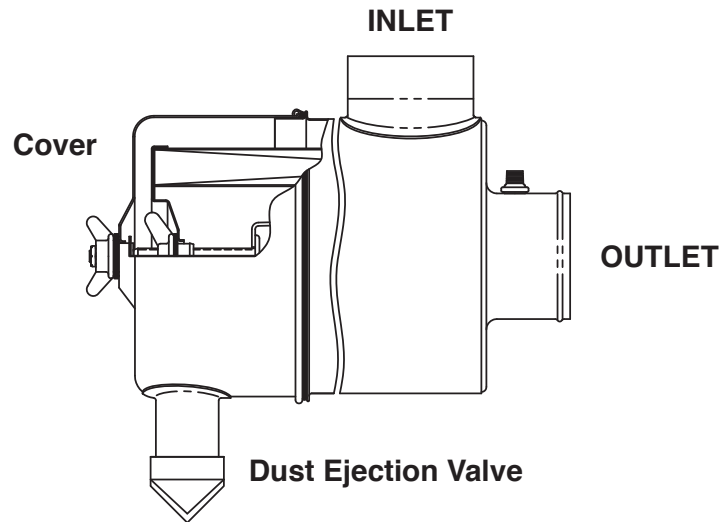

Specifications

Specification	AH19063	AH19064
Length Overall	17.7" (448.0 mm)	17.7" (448.0 mm)
Body OD, Max.	6.6" (166.4 mm)	6.6" (166.4 mm)
Flow, Min. (2" Restriction)	72 CFM (2.0 m ³ /min)	65 CFM (1.8 m ³ /min)
Flow, Max. (12" restriction)	188 CFM (5.3 m ³ /min)	168 CFM (4.8 m ³ /min)
Secondary Element	No	Yes
Housing Material	Metal	Metal
Pre-cleaner Integral	Yes	Yes
Filter Efficiency	≥ 99.90% per ISO 5011	≥ 99.90% per ISO 5011

Dust Holding Capacity per Cummins® Specification

Specification	AH19063	AH19064
Allowable Flow for 10 g/CFM	<184 CFM (5.2 m ³ /min)	< 159 CFM (4.5 m ³ /min)
Allowable Flow for 25 g/CFM	< 143 CFM (4.0 m ³ /min)	<123 CFM (3.5 m ³ /min)

Specifications subject to change without notice.

Ordering Information

Air Cleaners	
Part Number	Description
AH19063	Metal Air Cleaner – without Secondary Element
AH19064	Metal Air Cleaner – with Secondary Element

Accessories	
Part Number	Description
3918220S	Mounting Bracket
2	No. of Brackets Required
3316656S	Outlet Band Clamps
3918202S	Weather Hood
3316606S	Hump-Hose
3316566S	90° Elbow
N/A	90° Reducing Elbow
3946326S	Restriction Indicator

Service Parts	
Part Number	Description
AF1606K	Primary Element
AF1606KM	Magnum Primary Element
AF1982	Secondary Element
3946457S	Dust Ejection Valve
3955488S 3955489S	Wing Nut/Clips
3955470S	Cover Assembly

Dimensions

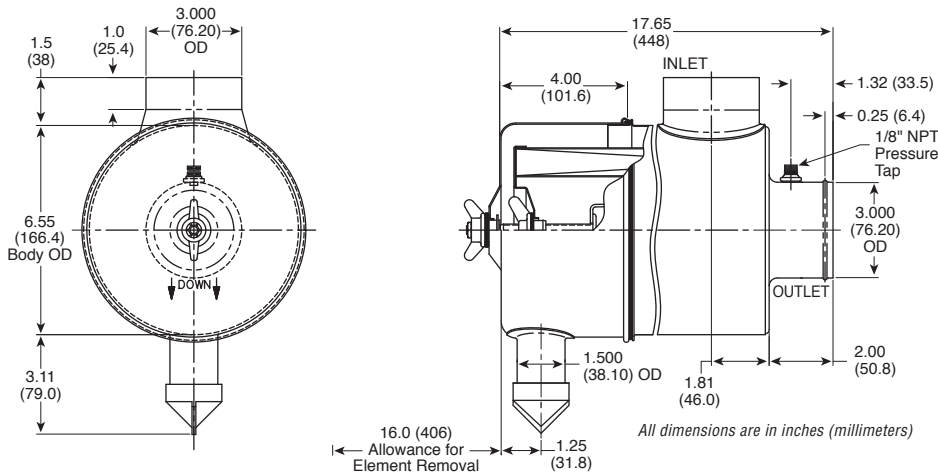

Performance

System Restriction vs Flow Rate

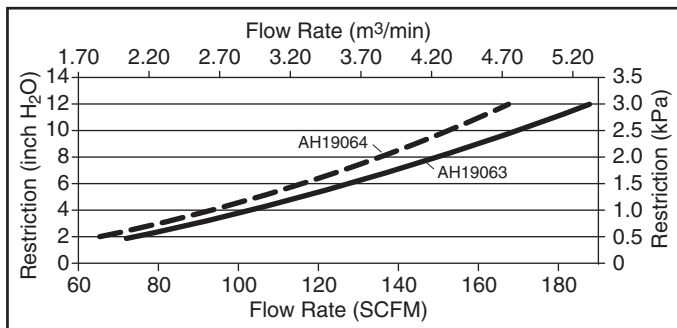

Typical System Capacity vs Flow Rate

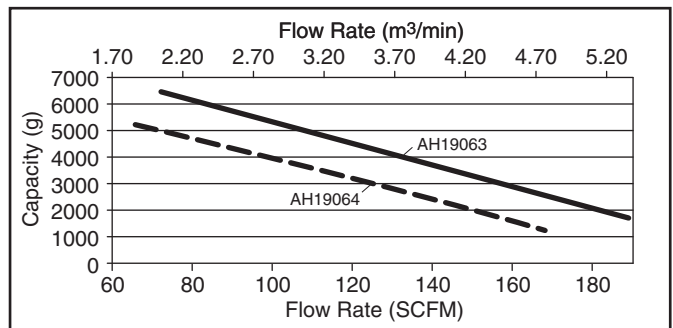

Restriction		Flow Rate () = with Secondary		Typical Capacity () = with Secondary
in H ₂ O	kPa	CFM	m ³ /min	grams
6	1.5	128 (116)	3.62 (3.29)	4159 (3316)
8	2.0	150 (135)	4.25 (3.82)	3258 (2552)
10	2.5	170 (153)	4.81 (4.33)	2450 (1850)
12	3.0	188 (168)	5.32 (4.76)	1710 (1192)

ISO Coarse Dust
2.0 g/m³ Feed Rate
6.25 kPa (25" H₂O) Terminal Restriction



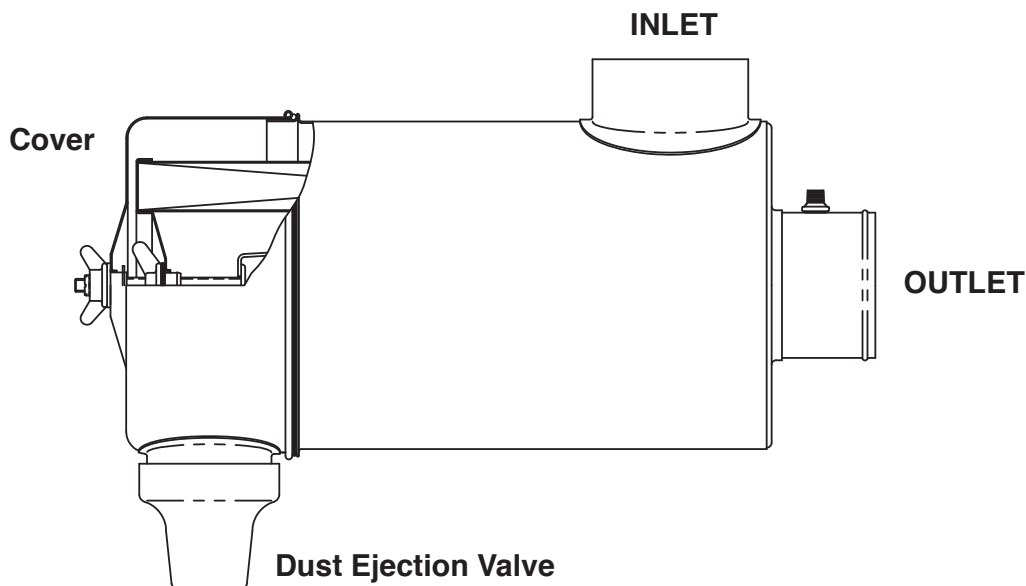

Specifications

Specification	AH19065	AH19066
Length Overall	16.1" (458.5 mm)	16.1" (458.5 mm)
Body OD, Max.	7.9" (200.4 mm)	7.9" (200.4 mm)
Flow, Min. (2" Restriction)	130 CFM (3.7 m ³ /min)	105 CFM (3.0 m ³ /min)
Flow, Max. (12" Restriction)	331 CFM (9.4 m ³ /min)	280 CFM (7.9 m ³ /min)
Secondary Element	No	Yes
Housing Material	Metal	Metal
Pre-cleaner Integral	Yes	Yes
Filter Efficiency	≥ 99.90% per ISO 5011	≥ 99.90% per ISO 5011

Dust Holding Capacity per Cummins® Specification

Specification	AH19065	AH19066
Allowable Flow for 10 g/CFM	< 331 CFM (9.4 m ³ /min)*	< 280 CFM (7.9 m ³ /min)*
Allowable Flow for 25 g/CFM	< 256 CFM (7.3 m ³ /min)	< 240 CFM (6.8 m ³ /min)

* Flow rate limited by restriction.

Specifications subject to change without notice.

Ordering Information

Air Cleaners	
Part Number	Description
AH19065	Metal Air Cleaner – without Secondary Element
AH19066	Metal Air Cleaner – with Secondary Element

Accessories	
Part Number	Description
3918222S	Mounting Bracket
2	No. of Brackets Required
3316657S	Outlet Band Clamps
3918203S	Weather Hood
3316607S	Hump-Hose
3316567S	90° Elbow
N/A	90° Reducing Elbow
3946326S	Restriction Indicator

Service Parts	
Part Number	Description
AF4059K	Primary Element
N/A	Magnum Primary Element
AF4103	Secondary Element
Q06316	Dust Ejection Valve
3955488S 3955489S	Wing Nut/Clips
3955469S	Cover Assembly

Dimensions

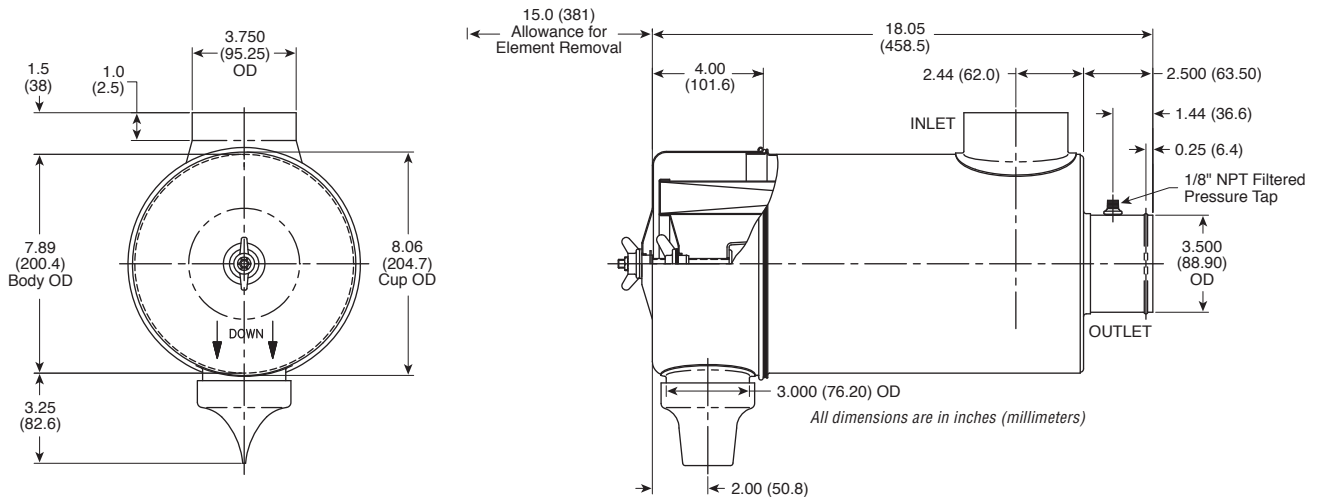

Performance

System Restriction vs Flow Rate

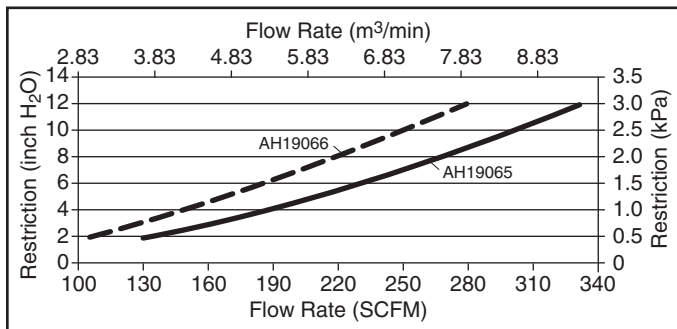

Typical System Capacity vs Flow Rate

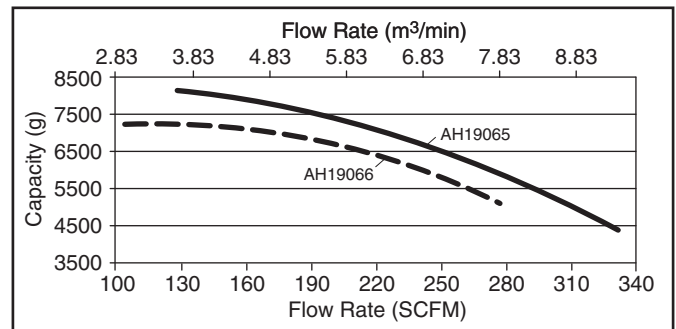

Restriction		Flow Rate () = with Secondary		Typical Capacity () = with Secondary
in H ₂ O	kPa	CFM	m ³ /min	grams
6	1.5	230 (185)	6.51 (5.24)	6927 (6897)
8	2.0	268 (219)	7.59 (6.20)	6146 (6415)
10	2.5	301 (251)	8.52 (7.11)	5302 (5787)
12	3.0	331 (280)	9.37 (7.93)	4412 (5042)

ISO Coarse Dust
2.0 g/m³ Feed Rate
6.25 kPa (25" H₂O) Terminal Restriction



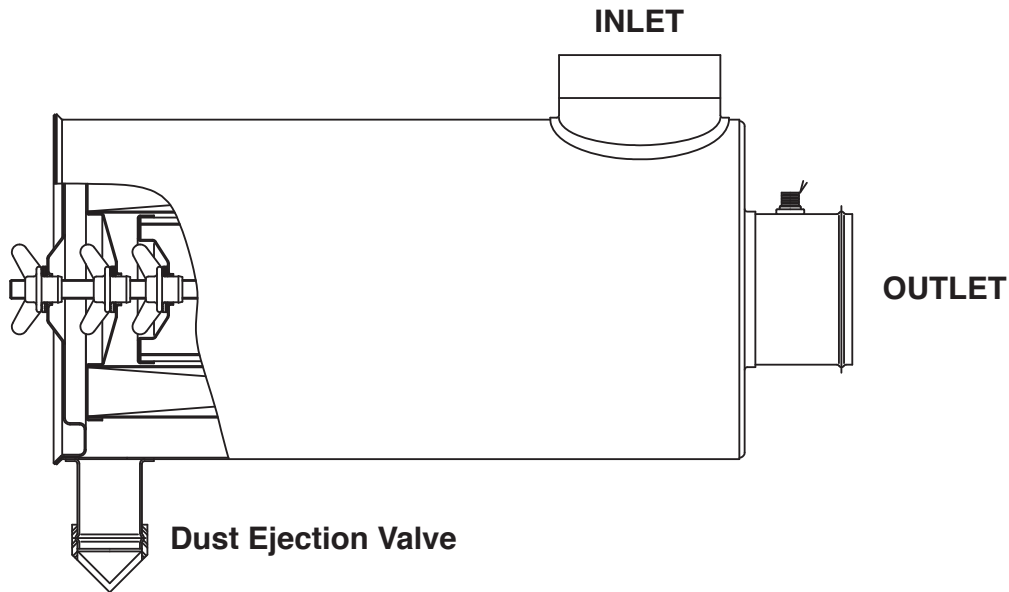

Specifications

Specification	AH19268
Length Overall	16.0" (406.7 mm)
Body OD, Max.	7.9" (200.4 mm)
Flow, Min. (2" Restriction)	140 CFM (4.0 m ³ /min)
Flow, Max. (12" Restriction)	317 CFM (9.0 m ³ /min)
Secondary Element	No
Housing Material	Metal
Pre-cleaner Integral	Yes
Filter Efficiency	≥ 99.90% per ISO 5011

Dust Holding Capacity per Cummins® Specification

Specification	AH19268
Allowable Flow for 10 g/CFM	< 317 CFM (9.0 m ³ /min)*
Allowable Flow for 25 g/CFM	< 223 CFM (6.3 m ³ /min)

* Flow rate limited by restriction. Specifications subject to change without notice.

Ordering Information

Air Cleaners	
Part Number	Description
AH19268	Metal Air Cleaner – without Secondary Element

Accessories	
Part Number	Description
3918222S	Mounting Bracket
2	No. of Brackets Required
3316657S	Outlet Band Clamps
3918203S	Weather Hood
3316607S	Hump-Hose
3316567S	90° Elbow
N/A	90° Reducing Elbow
3946326S	Restriction Indicator

Service Parts	
Part Number	Description
AF4059K	Primary Element
N/A	Magnum Primary Element
AF4103	Secondary Element
3946457S	Dust Ejection Valve
3955485S	Wing Nut/Clips
3955463S	Cover Assembly

Dimensions

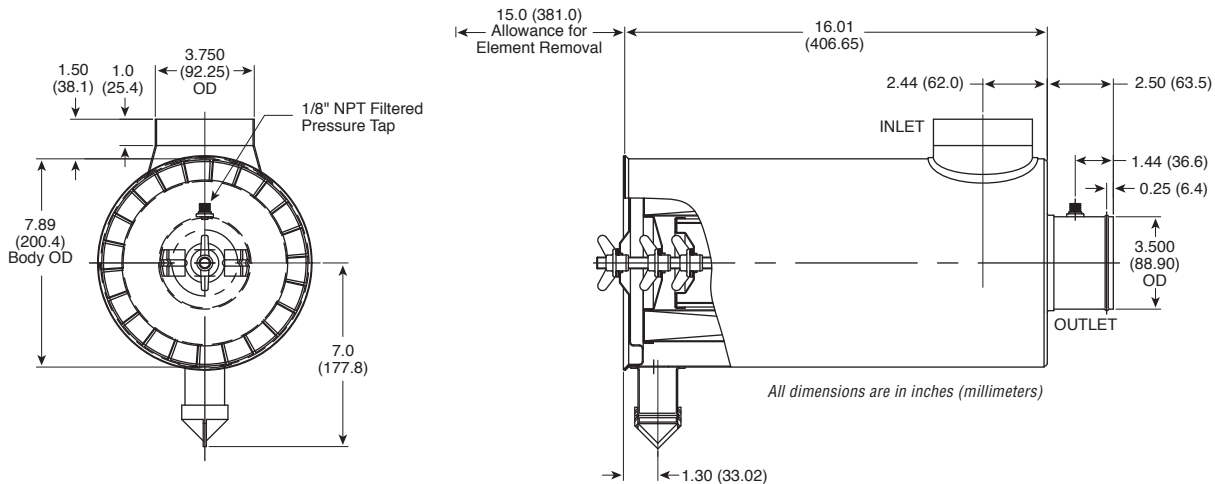

Performance

System Restriction vs Flow Rate

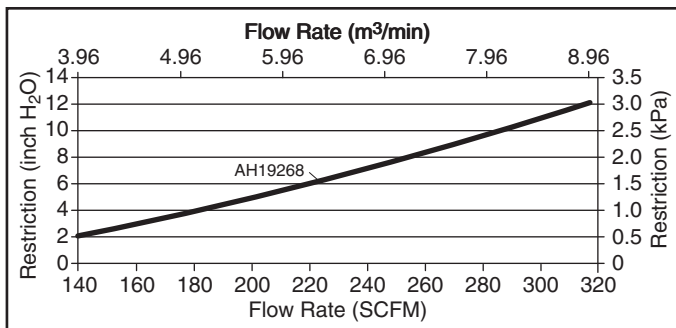

Typical System Capacity vs Flow Rate

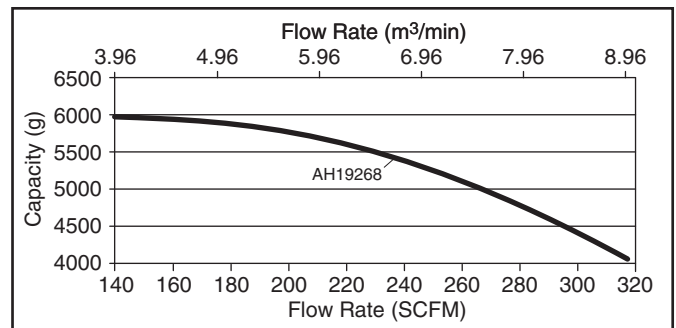

Restriction		Flow Rate		Typical Capacity
in H ₂ O	kPa	CFM	m³/min	grams
6	1.5	221	6.26	5598
8	2.0	255	7.22	5187
10	2.5	287	8.13	4675
12	3.0	317	8.98	4083

ISO Coarse Dust
2.0 g/m³ Feed Rate
6.25 kPa (25" H₂O) Terminal Restriction



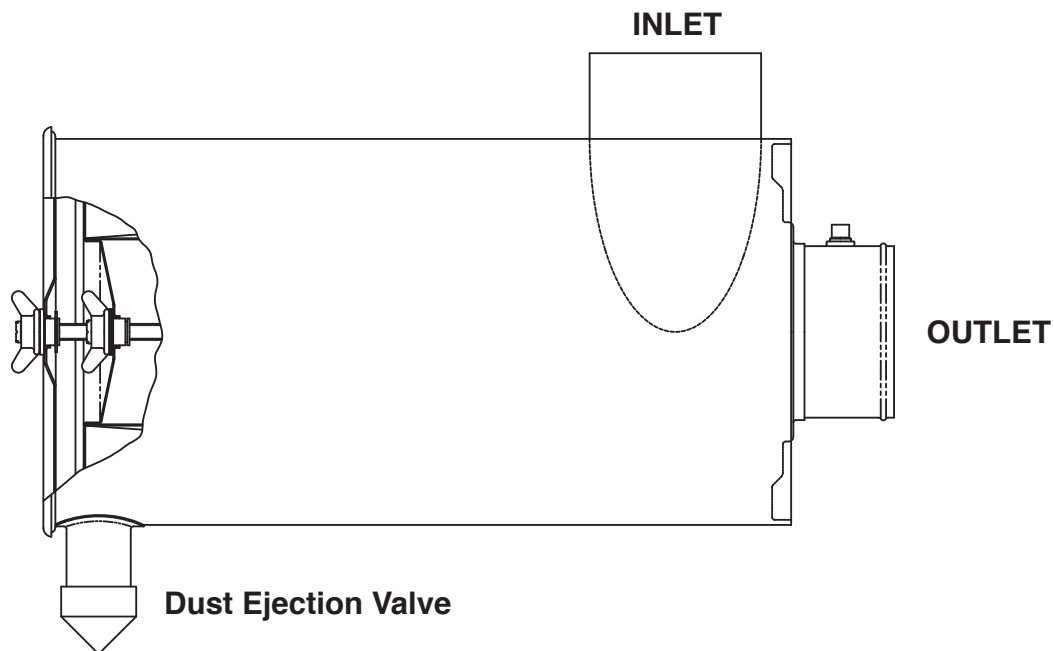

Specifications

Specification	AH19270	AH19269
Length Overall	20.1" (519.4 mm)	20.1" (519.4 mm)
Body OD, Max.	9.0" (227.33 mm)	9.0" (227.3 mm)
Flow, Min. (2" Restriction)	180 CFM (5.1 m ³ /min)	150 CFM (4.2 m ³ /min)
Flow, Max. (12" Restriction)	460 CFM (13.0 m ³ /min)	383 CFM (10.9 m ³ /min)
Secondary Element	No	No
Housing Material	Metal	Metal
Pre-cleaner Integral	Yes	Yes
Filter Efficiency	≥ 99.90% per ISO 5011	≥ 99.90% per ISO 5011

Dust Holding Capacity per Cummins® Specification

Specification	AH19270	AH19269
Allowable Flow for 10 g/CFM	< 403 CFM (11.4 m ³ /min)	< 368 CFM (10.4 m ³ /min)
Allowable Flow for 25 g/CFM	< 279 CFM (7.9 m ³ /min)	< 269 CFM (7.6 m ³ /min)

Specifications subject to change without notice.

Ordering Information

Air Cleaners	
Part Number	Description
AH19270	Metal Air Cleaner – without Secondary Element
AH19269	Metal Air Cleaner – with Secondary Element

Accessories	
Part Number	Description
3918225S	Mounting Bracket
2	No. of Brackets Required
3316658S	Outlet Band Clamps
3918204S	Weather Hood
3316608S	Hump-Hose
3316568S	90° Elbow
N/A	90° Reducing Elbow
3946326S	Restriction Indicator

Service Parts	
Part Number	Description
AF1735K	Primary Element
N/A	Magnum Primary Element
AF4150	Secondary Element
Q06316	Dust Ejection Valve
3955484S 3955481S	Wing Nut/Clips
3955461S	Cover Assembly

Dimensions

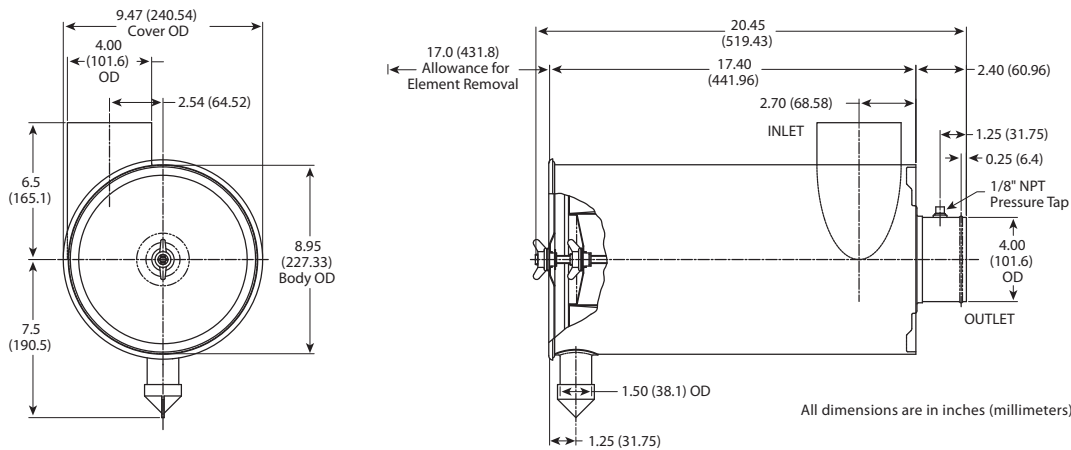

Performance

System Restriction vs Flow Rate

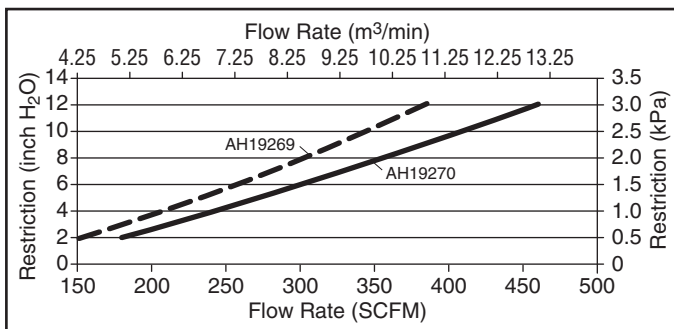

Typical System Capacity vs Flow Rate

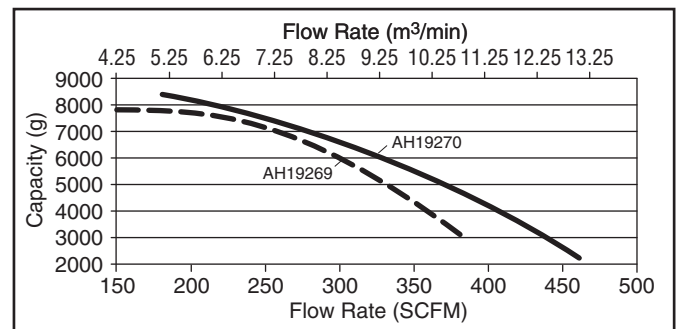

Restriction		Flow Rate () = with Secondary		Typical Capacity () = with Secondary
in H ₂ O	kPa	CFM	m³/min	grams
6	1.5	302 (259)	8.55 (7.33)	6924 (6510)
8	2.0	358 (304)	10.14 (8.61)	5864 (5245)
10	2.5	410 (345)	11.61 (9.77)	4550 (3812)
12	3.0	460(383)	13.03 (10.85)	2236 (3042)

ISO Coarse Dust
2.0 g/m³ Feed Rate
6.25 kPa (25" H₂O) Terminal Restriction



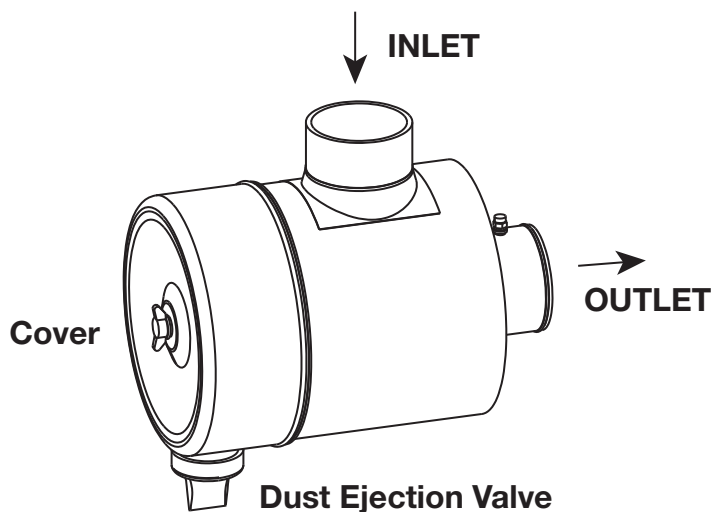

Specifications

Specification	AH19069	AH19070
Length Overall	18.5" (469.4 mm)	18.5" (469.4 mm)
Body OD, Max.	12.1" (306.6 mm)	12.1" (306.6 mm)
Flow, Min. (2" Restriction)	240 CFM (6.8 m ³ /min)	175 CFM (5.0 m ³ /min)
Flow, Max. (12" Restriction)	631 CFM (17.9 m ³ /min)	447 CFM (12.7 m ³ /min)
Secondary Element	No	Yes
Housing Material	Metal	Metal
Pre-cleaner Integral	Yes	Yes
Filter Efficiency	≥ 99.90% per ISO 5011	≥ 99.90% per ISO 5011

Dust Holding Capacity per Cummins® Specification

Specification	AH19069	AH19070
Allowable Flow for 3 g/CFM	< 615 CFM (17.4 m ³ /min)	< 441 CFM (12.5 m ³ /min)
Allowable Flow for 10 g/CFM	< 495 CFM (14.0 m ³ /min)	< 441 CFM (12.5 m ³ /min)
Allowable Flow for 25 g/CFM	< 329 CFM (9.3 m ³ /min)	< 320 CFM (9.1 m ³ /min)

Specifications subject to change without notice.

Ordering Information

Air Cleaners	
Part Number	Description
AH19069	Metal Air Cleaner – without Secondary Element
AH19070	Metal Air Cleaner – with Secondary Element

Accessories	
Part Number	Description
3918231S	Mounting Bracket
2	No. of Brackets Required
3316660S	Outlet Band Clamps
3918205S	Weather Hood
3316610S	Hump-Hose
3316570S	90° Elbow
N/A	90° Reducing Elbow
3946326S	Restriction Indicator

Service Parts	
Part Number	Description
AF418	Primary Element
AF418M	Magnum Primary Element
AF490M	Secondary Element
Q06316	Dust Ejection Valve
3955482S	Wing Nut/Clips
3955487S	
3955466S	Cover Assembly

Dimensions

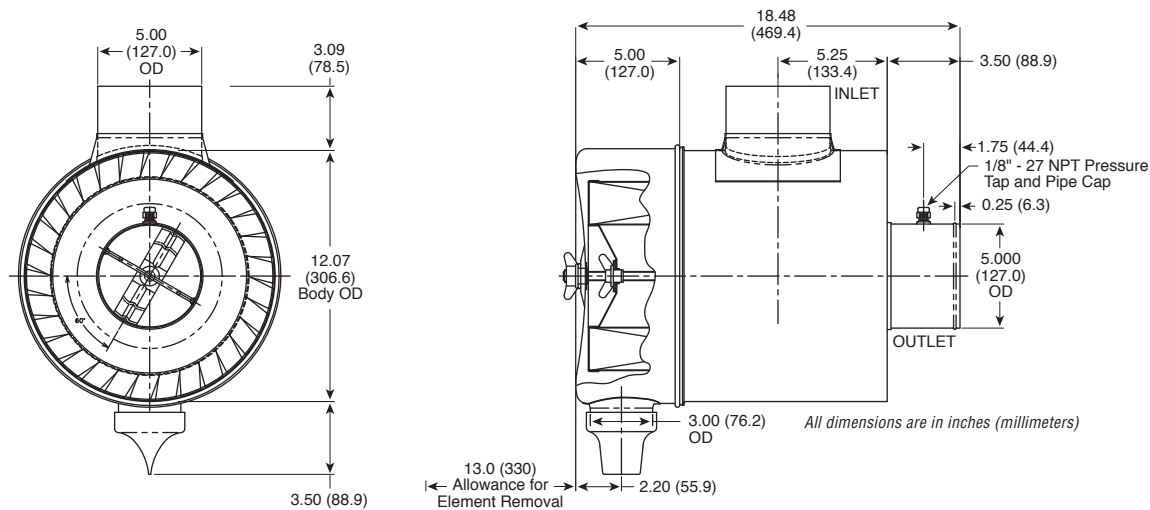

Performance

System Restriction vs Flow Rate

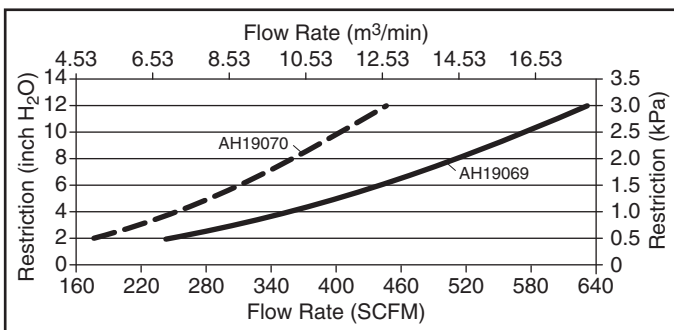

Typical System Capacity vs Flow Rate

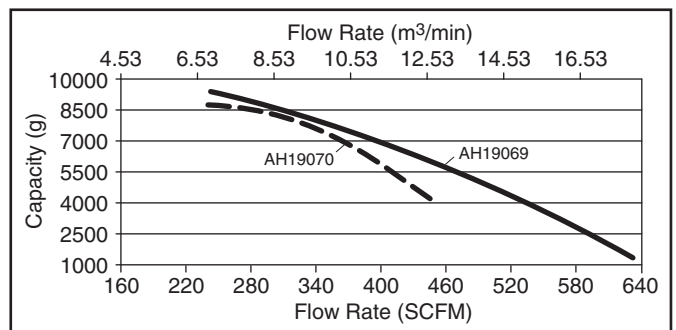

Restriction		Flow Rate () = with Secondary		Typical Capacity () = with Secondary
in H ₂ O	kPa	CFM	m ³ /min	grams
6	1.5	439 (310)	12.43 (8.78)	6187 (8161)
8	2.0	511 (361)	14.47 (10.22)	4580 (7101)
10	2.5	574 (406)	16.26 (11.50)	2984 (5743)
12	3.0	631 (447)	17.87 (12.66)	1397 (4171)

ISO Coarse Dust
2.0 g/m³ Feed Rate
6.25 kPa (25" H₂O) Terminal Restriction



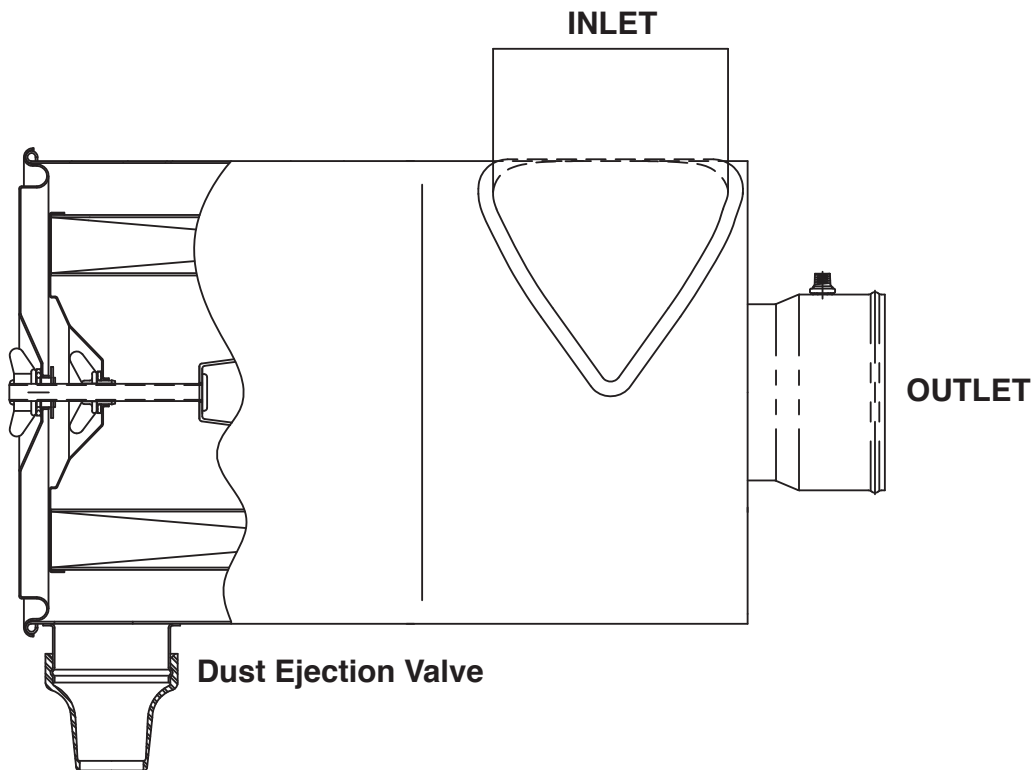

Specifications

Specification	AH19271	AH19272
Length Overall	21.9" (556.3 mm)	21.9" (556.3 mm)
Body OD, Max.	11.0" (279.7 mm)	11.0" (279.7 mm)
Flow, Min. (2" Restriction)	400 CFM (11.3 m ³ /min)	270 CFM (7.7 m ³ /min)
Flow, Max. (12" Restriction)	767 CFM (21.7 m ³ /min)	686 CFM (19.4 m ³ /min)
Secondary Element	No	Yes
Housing Material	Metal	Metal
Pre-cleaner Integral	Yes	Yes
Filter Efficiency	≥ 99.90% per ISO 5011	≥ 99.90% per ISO 5011

Dust Holding Capacity per Cummins® Specification

Specification	AH19271	AH19272
Allowable Flow for 10 g/CFM	< 674 CFM (19.1 m ³ /min)	< 653 CFM (18.5 m ³ /min)
Allowable Flow for 25 g/CFM	< 445 CFM (12.6 m ³ /min)	< 401 CFM (11.4 m ³ /min)

Specifications subject to change without notice.

Ordering Information

Air Cleaners	
Part Number	Description
AH19271	Metal Air Cleaner – without Secondary Element
AH19272	Metal Air Cleaner – with Secondary Element

Accessories	
Part Number	Description
3918230S	Mounting Bracket
2	No. of Brackets Required
3316660S	Outlet Band Clamps
3918206S	Weather Hood
3316610S	Hump-Hose
3316570S	90° Elbow
N/A	90° Reducing Elbow
3946326S	Restriction Indicator

Service Parts	
Part Number	Description
AF4754	Primary Element
N/A	Magnum Primary Element
AF4755	Secondary Element
Q06316	Dust Ejection Valve
3955487S	Wing Nut/Clips
3955482S	
3955462S	Cover Assembly

Dimensions

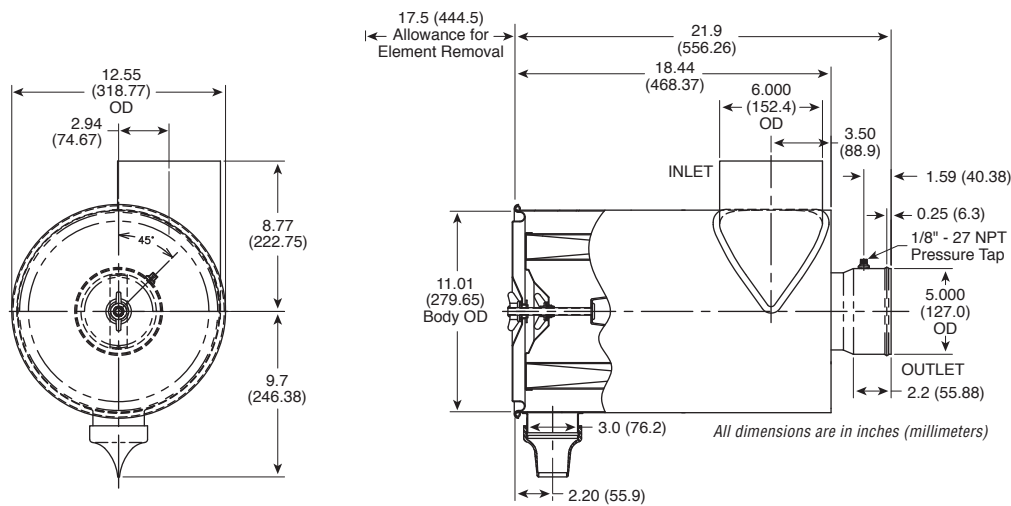

Performance

System Restriction vs Flow Rate

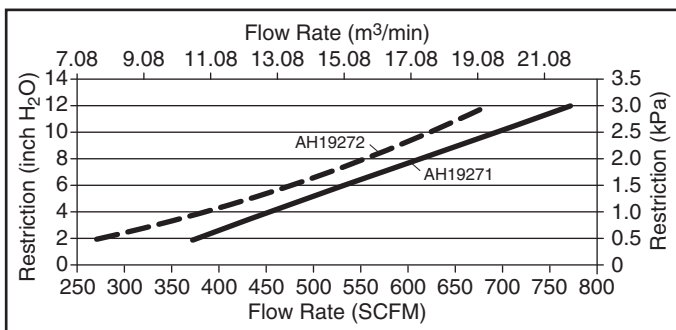

Typical System Capacity vs Flow Rate

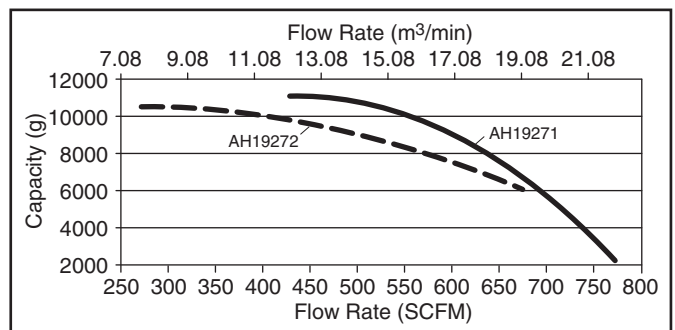

Restriction		Flow Rate () = with Secondary		Typical Capacity () = with Secondary
in H ₂ O	kPa	CFM	m³/min	grams
6	1.5	532 (480)	15.07 (13.59)	10442 (9294)
8	2.0	612 (557)	17.33 (15.77)	8749 (8263)
10	2.5	692 (625)	19.60 (17.70)	6036 (7100)
12	3.0	772 (686)	21.86 (19.43)	2303 (5844)

ISO Coarse Dust
2.0 g/m³ Feed Rate
6.25 kPa (25" H₂O) Terminal Restriction



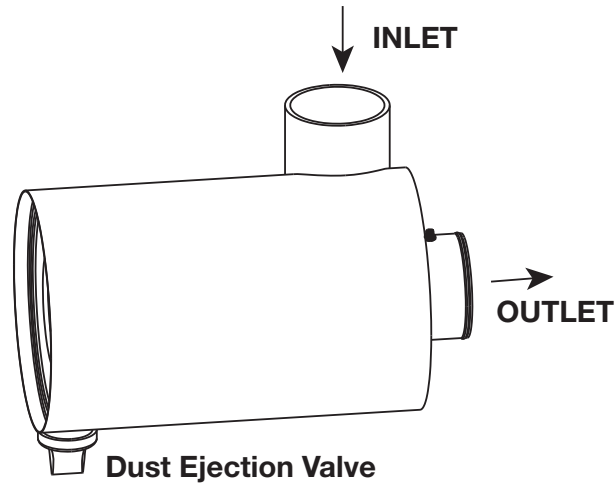

Specifications

Specification	AH19259
Length Overall	25.1" (636.3 mm)
Body OD	14.1" (358.1 mm)
Flow, Min. (2" Restriction)	355 CFM (10.1 m ³ /min)
Flow, Max. (12" Restriction)	897 CFM (25.4 m ³ /min)
Secondary Element	Yes
Housing Material	Metal
Pre-cleaner Integral	Yes
Filter Efficiency	≥ 99.90% per ISO 5011

Dust Holding Capacity per Cummins® Specification

Specification	AH19259
Allowable Flow for 10 g/CFM	< 897 CFM (25.4 m ³ /min)*
Allowable Flow for 25 g/CFM	< 841 CFM (23.8 m ³ /min)

* Flow rate limited by restriction. Specifications subject to change without notice.

Ordering Information

Air Cleaner	
Part Number	Description
AH19259	Metal Air Cleaner

Accessories	
Part Number	Description
3918234S	Mounting Bracket
2	No. of Brackets Required
3316662S	Outlet Band Clamps
3918206S 3918207S	Weather Hood
3316612S	Hump-Hose
3316573S	90° Elbow
3316589S 3316590S	90° Reducing Elbow
3946326 S	Restriction Indicator

Service Parts	
Part Number	Description
AF1828	Primary Element
N/A	Magnum Primary Element
AF1894M	Secondary Element
Q06316	Dust Ejection Valve
3955490S	Wing Nut/Clips
N/A	Cover Assembly

Dimensions

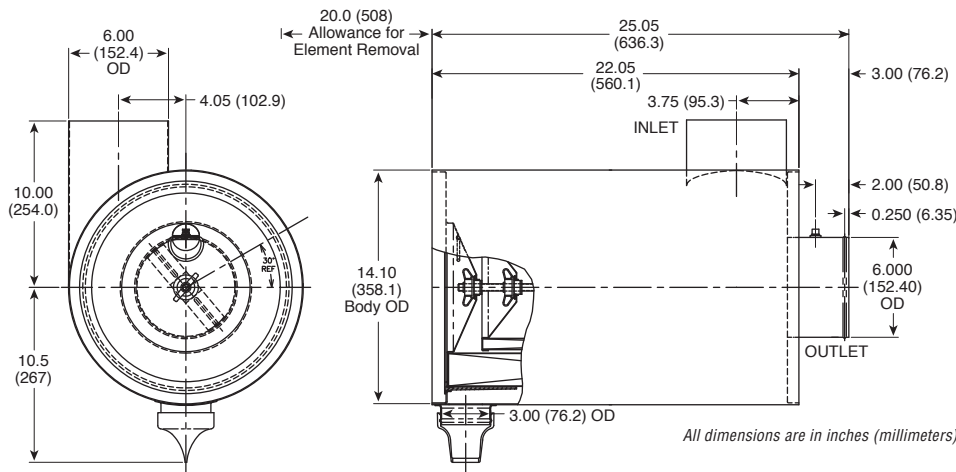

Performance

System Restriction vs Flow Rate

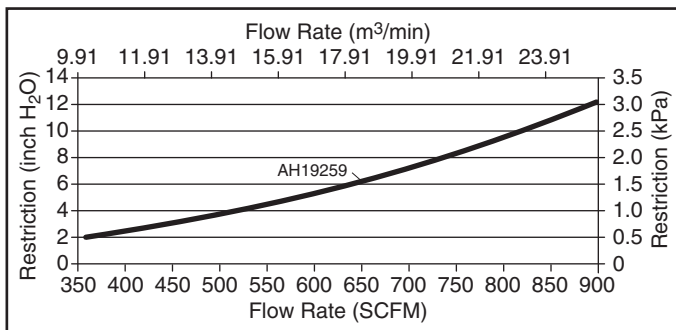

Typical System Capacity vs Flow Rate

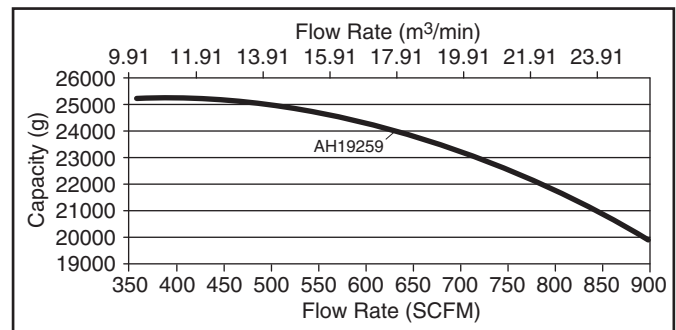

Restriction		Flow Rate		Typical Capacity
in H ₂ O	kPa	CFM	m ³ /min	grams
6	1.5	640	18.12	23918
8	2.0	737	20.87	22728
10	2.5	821	23.25	21390
12	3.0	897	25.40	19950

ISO Coarse Dust
2.0 g/m³ Feed Rate
6.25 kPa (25" H₂O) Terminal Restriction



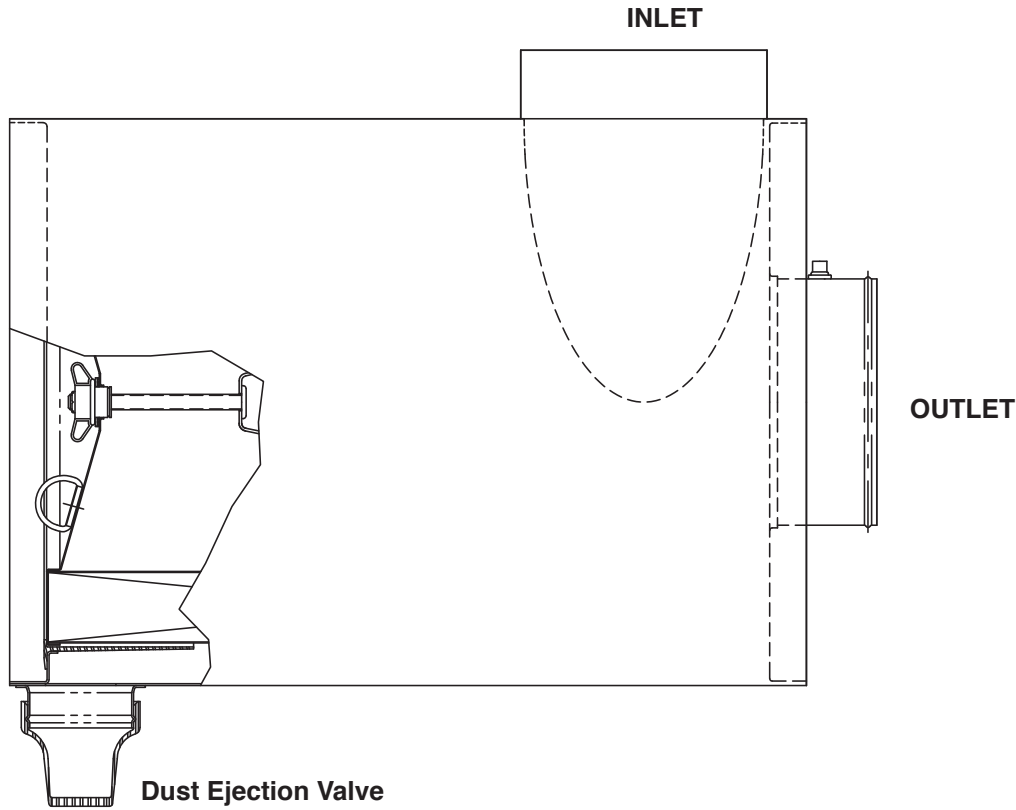

Specifications

Specification	AH19073	AH19074
Length Overall	24.6" (625.9 mm)	24.6" (625.9 mm)
Body OD, Max.	16.1" (408.9 mm)	16.1" (408.9 mm)
Flow, Min. (2" Restriction)	570 CFM (16.4 m ³ /min)	555 CFM (15.7 m ³ /min)
Flow, Max. (12" Restriction)	1275 CFM (36.1 m ³ /min)	1224 CFM (34.7 m ³ /min)
Secondary Element	No	Yes
Housing Material	Metal	Metal
Pre-cleaner Integral	Yes	Yes
Filter Efficiency	≥ 99.90% per ISO 5011	≥ 99.90% per ISO 5011

Dust Holding Capacity per Cummins® Specification

Specification	AH19073	AH19074
Allowable Flow for 10 g/CFM	< 1275 CFM (36.1 m ³ /min)*	1224 CFM (34.7 m ³ /min)*
Allowable Flow for 25 g/CFM	< 938 CFM (26.6 m ³ /min)	917 CFM (26.0 m ³ /min)

* Flow rate limited by restriction.

Specifications subject to change without notice.

Ordering Information

Air Cleaners	
Part Number	Description
AH19073	Metal Air Cleaner – without Secondary Element
AH19074	Metal Air Cleaner – with Secondary Element

Accessories	
Part Number	Description
3918236S	Mounting Bracket
2	No. of Brackets Required
3316663S	Outlet Band Clamps
3918208S 3918209S	Weather Hood
3316613S	Hump-Hose
3316576S	90° Elbow
3316591S 3316592S 3316593S	90° Reducing Elbow
3946326S	Restriction Indicator

Service Parts	
Part Number	Description
AF4553M	Primary Element
AF4553M	Magnum Primary Element
AF4554M	Secondary Element
Q06316	Dust Ejection Valve
3955490S	Wing Nut/Clips
N/A	Cover Assembly

Dimensions

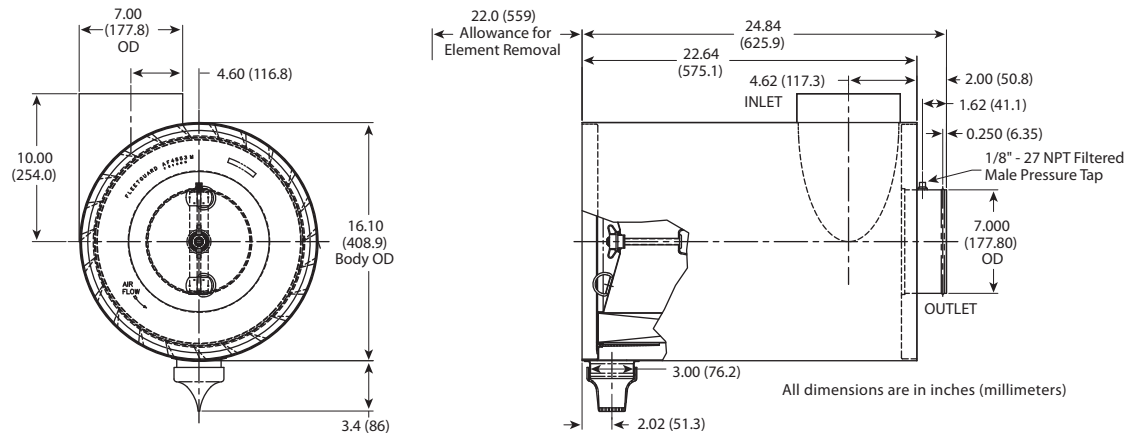

Performance

System Restriction vs Flow Rate

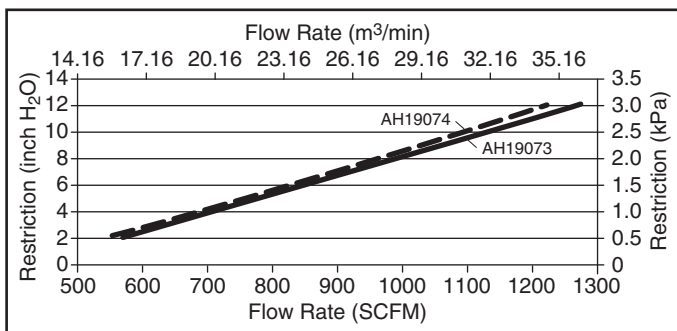

Typical System Capacity vs Flow Rate

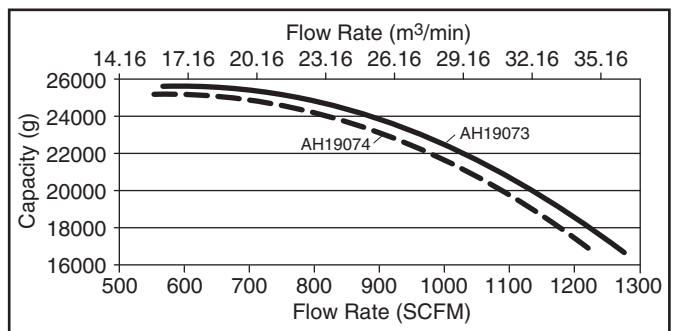

Restriction		Flow Rate () = with Secondary		Flow Rate () = with Secondary
in H ₂ O	kPa	CFM	m ³ /min	grams
6	1.5	844 (832)	23.90 (23.56)	24507 (23938)
8	2.0	987 (967)	27.95 (27.39)	22726 (22166)
10	2.5	1131 (1098)	32.03 (31.10)	20130 (19751)
12	3.0	1275 (1224)	36.11 (34.66)	16719 (16757)

ISO Coarse Dust
2.0 g/m³ Feed Rate
6.25 kPa (25" H₂O) Terminal Restriction



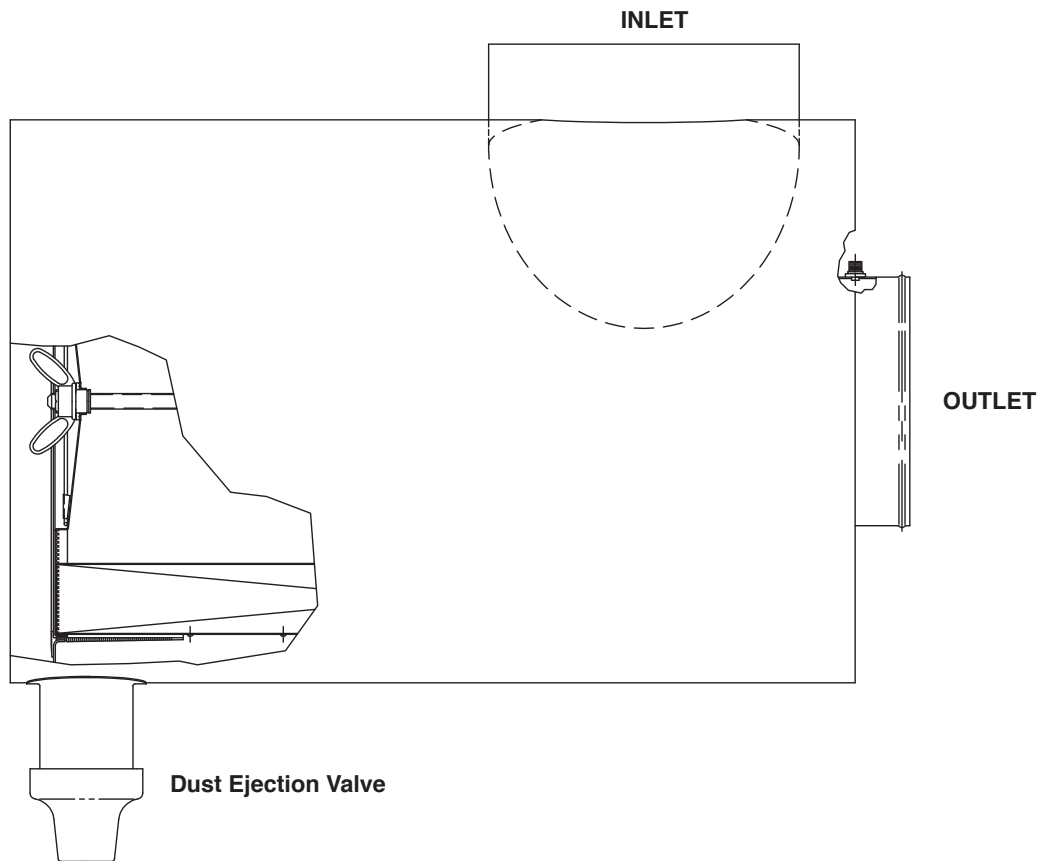

Specifications

Specification	AH19075	AH19076
Length Overall	27.3" (693.0 mm)	27.3" (693.0 mm)
Body OD, Max.	18.1" (460.2 mm)	18.1" (460.2 mm)
Flow, Min. (2" Restriction)	700 CFM (19.8 m ³ /min)	650 CFM (18.4 m ³ /min)
Flow, Max. (12" Restriction)	1815 CFM (51.4 m ³ /min)	1765 CFM (50.0 m ³ /min)
Secondary Element	No	Yes
Housing Material	Metal	Metal
Pre-cleaner Integral	Yes	Yes
Filter Efficiency	≥ 99.90% per ISO 5011	≥ 99.90% per ISO 5011

Dust Holding Capacity per Cummins® Specification

Specification	AH19075	AH19076
Allowable Flow for 10 g/CFM	< 1815 CFM (51.4 m ³ /min)*	1765 CFM (50.0 m ³ /min)*
Allowable Flow for 25 g/CFM	< 1320 CFM (37.4 m ³ /min)	1260 CFM (35.9 m ³ /min)

* Flow rate limited by restriction.

Specifications subject to change without notice.

Ordering Information

Air Cleaners	
Part Number	Description
AH19075	Metal Air Cleaner – without Secondary Element
AH19076	Metal Air Cleaner – with Secondary Element

Accessories	
Part Number	Description
3918237S	Mounting Bracket
2	No. of Brackets Required
3316664S	Outlet Band Clamps
3940356S	Weather Hood
3316614S	Hump-Hose
3316577S	90° Elbow
N/A	90° Reducing Elbow
3946326S	Restriction Indicator

Service Parts	
Part Number	Description
AF25544	Primary Element
N/A	Magnum Primary Element
AF25545	Secondary Element
Q06316	Dust Ejection Valve
3955479S	Wing Nut/Clips
N/A	Cover Assembly

Dimensions

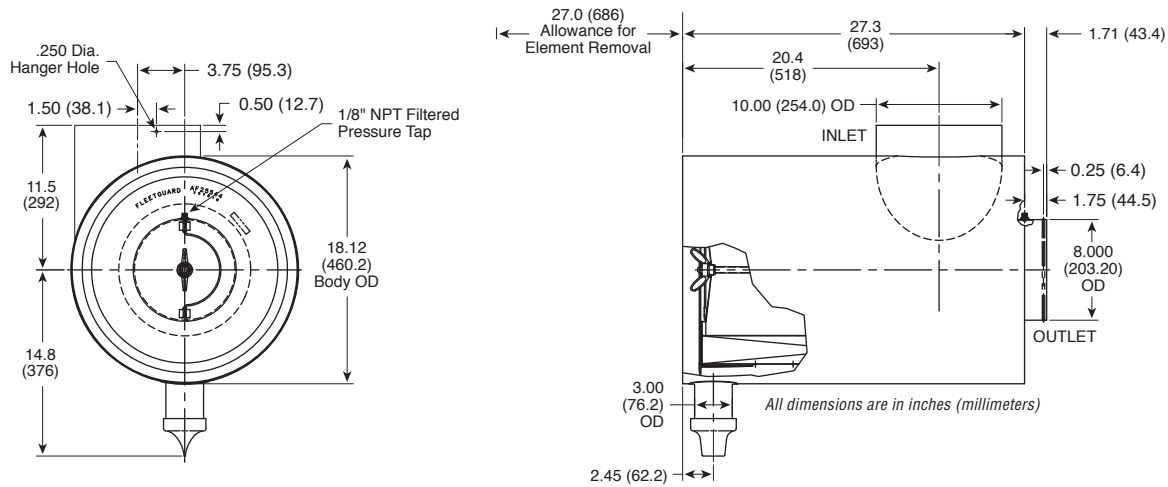

Performance

System Restriction vs Flow Rate

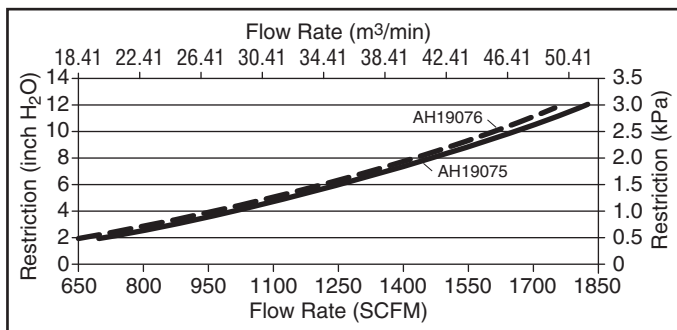

Typical System Capacity vs Flow Rate

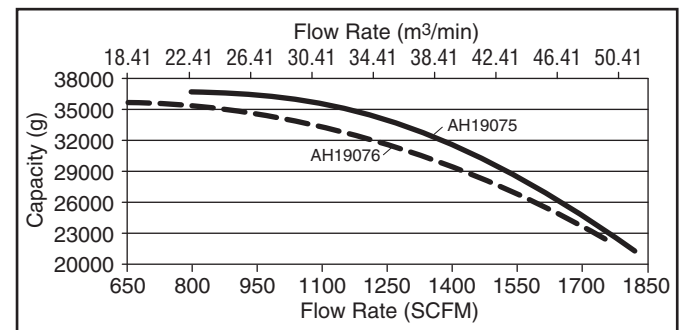

Restriction		Flow Rate () = with Secondary		Typical Capacity () = with Secondary
in H ₂ O	kPa	CFM	m³/min	grams
6	1.5	1250 (1211)	35.40 (34.30)	33992 (32113)
8	2.0	1461 (1418)	41.38 (40.16)	30490 (29169)
10	2.5	1650 (1600)	46.73 (45.31)	26181 (25850)
12	3.0	1821 (1765)	51.57 (49.98)	21281 (22266)

ISO Coarse Dust
2.0 g/m³ Feed Rate
6.25 kPa (25" H₂O) Terminal Restriction



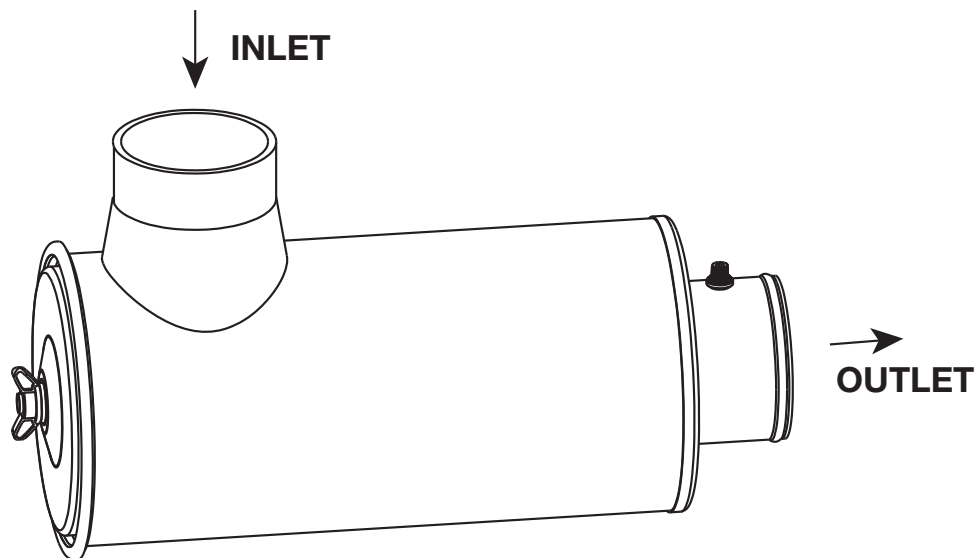

Specifications

Specification	AH19077
Length Overall	17.9" (454.9 mm)
Body OD	7.2" (182.4 mm)
Flow, Min. (2" Restriction)	188 CFM (5.3 m ³ /min)
Flow, Max. (12" restriction)	468 CFM (13.3 m ³ /min)
Secondary Element	No
Housing Material	Metal
Pre-cleaner Integral	No
Filter Efficiency	≥ 99.90% per ISO 5011

Dust Holding Capacity per Cummins® Specification

Specification	AH19077
Allowable Flow for 3 g/CFM	< 329 CFM (9.3 m ³ /min)
Allowable Flow for 10 g/CFM	< 181 CFM (5.1 m ³ /min)

Specifications subject to change without notice.

Ordering Information

Air Cleaner	
Part Number	Description
AH19077	Metal Air Cleaner

Accessories	
Part Number	Description
3918221S	Mounting Bracket
2	No. of Brackets Required
3316658S	Outlet Band Clamps
3918204S	Weather Hood
3316608S	Hump-Hose
3316568S	90° Elbow
N/A	90° Reducing Elbow
3946326S	Restriction Indicator

Service Parts	
Part Number	Description
AF25546	Primary Element
N/A	Magnum Primary Element
N/A	Secondary Element
Q06316	Dust Ejection Valve
3955488S	Wing Nut/Clips
3955489S	
3955471S	Cover Assembly

Dimensions

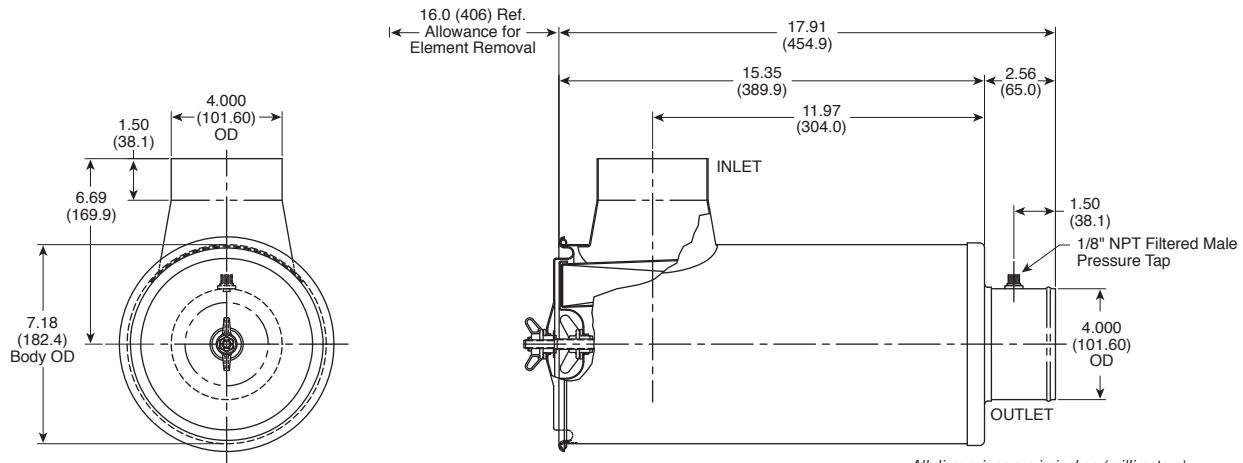

All dimensions are in inches (millimeters)

Performance

System Restriction vs Flow Rate

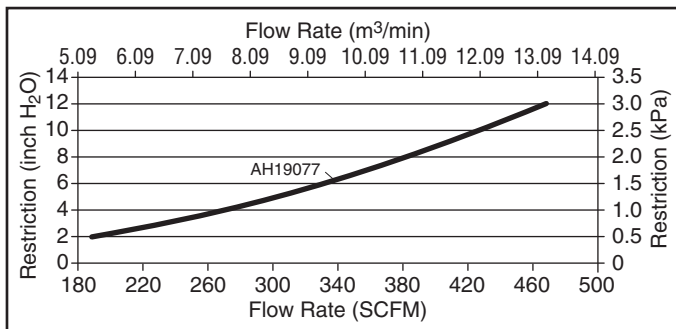

Typical System Capacity vs Flow Rate

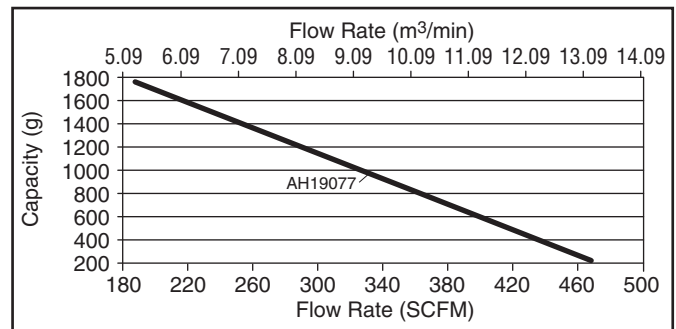

Restriction		Flow Rate		Typical Capacity
in H ₂ O	kPa	CFM	m ³ /min	grams
6	1.5	331	9.37	980
8	2.0	382	10.82	696
10	2.5	428	12.12	447
12	3.0	468	13.25	223

ISO Fine Dust
 1.0 g/m³ Feed Rate
 6.25 kPa (25" H₂O) Terminal Restriction



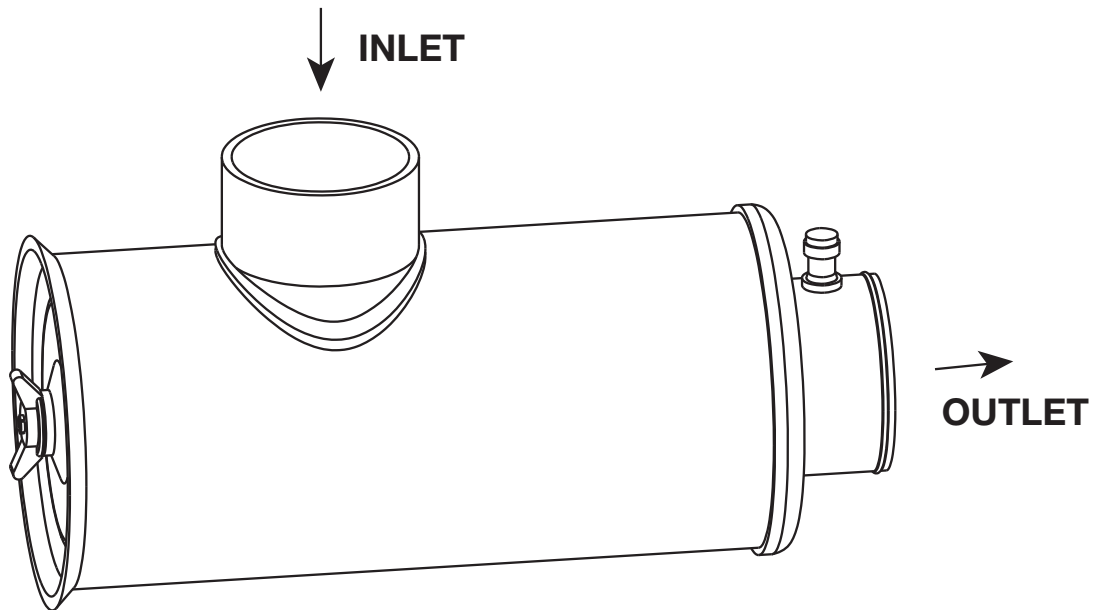

Specifications

Specification	AH19078
Length Overall	21.5" (547.1 mm)
Body OD	8.5" (216.4 mm)
Flow, Min. (2" Restriction)	310 CFM (8.8 m ³ /min)
Flow, Max. (12" Restriction)	791 CFM (22.4 m ³ /min)
Secondary Element	No
Housing Material	Metal
Pre-cleaner Integral	No
Filter Efficiency	≥ 99.90% per ISO 5011

Dust Holding Capacity per Cummins® Specification

Specification	AH19078
Allowable Flow for 3 g/CFM	< 520 CFM (14.7 m ³ /min)
Allowable Flow for 10 g/CFM	< 250 CFM (7.1 m ³ /min)

Specifications subject to change without notice.

Ordering Information

Air Cleaner	
Part Number	Description
AH19078	Metal Air Cleaner

Accessories	
Part Number	Description
3918224S	Mounting Bracket
2	No. of Brackets Required
3316660S	Outlet Band Clamps
3918205S	Weather Hood
3316610S	Hump-Hose
3316570S	90° Elbow
N/A	90° Reducing Elbow
3946326S	Restriction Indicator

Service Parts	
Part Number	Description
AF25547	Primary Element
N/A	Magnum Primary Element
N/A	Secondary Element
Q06316	Dust Ejection Valve
3955488S	Wing Nut/Clips
3955489S	
3955473S	Cover Assembly

Dimensions

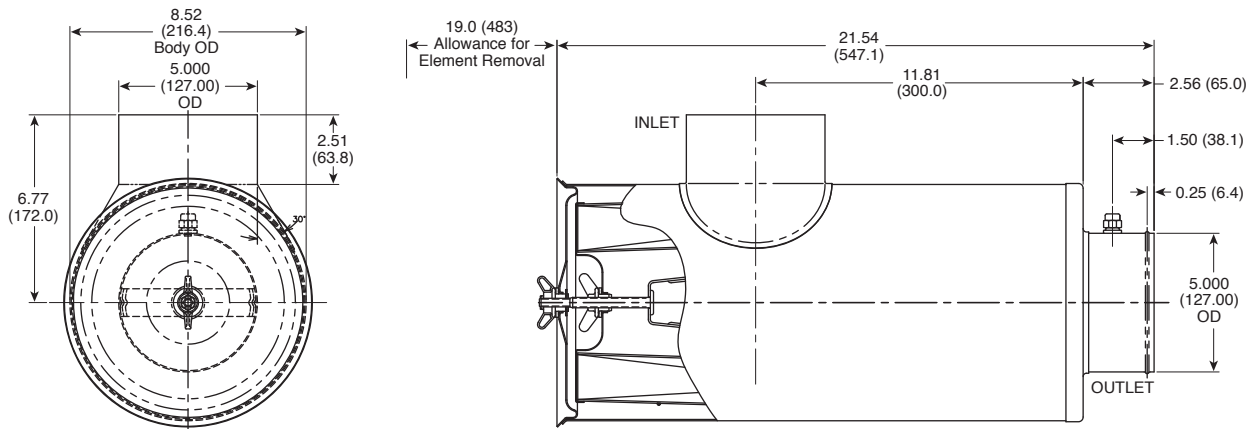

All dimensions are in inches (millimeters)

Performance

System Restriction vs Flow Rate

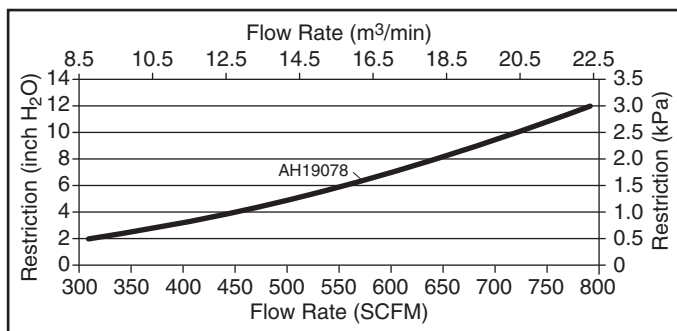

Typical System Capacity vs Flow Rate

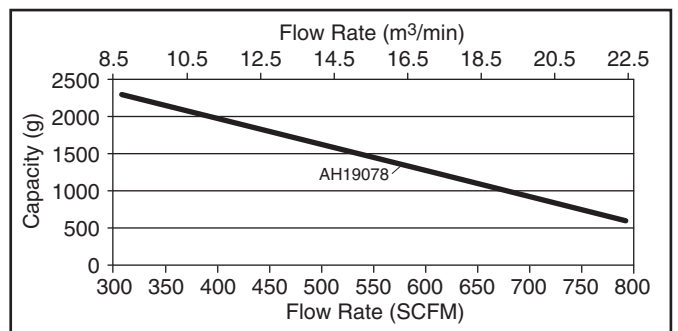

Restriction		Flow Rate		Typical Capacity
in H ₂ O	kPa	CFM	m ³ /min	grams
6	1.5	555	15.72	1434
8	2.0	643	18.21	1125
10	2.5	721	20.42	853
12	3.0	791	22.40	608

ISO Fine Dust
 1.0 g/m³ Feed Rate
 6.25 kPa (25" H₂O) Terminal Restriction



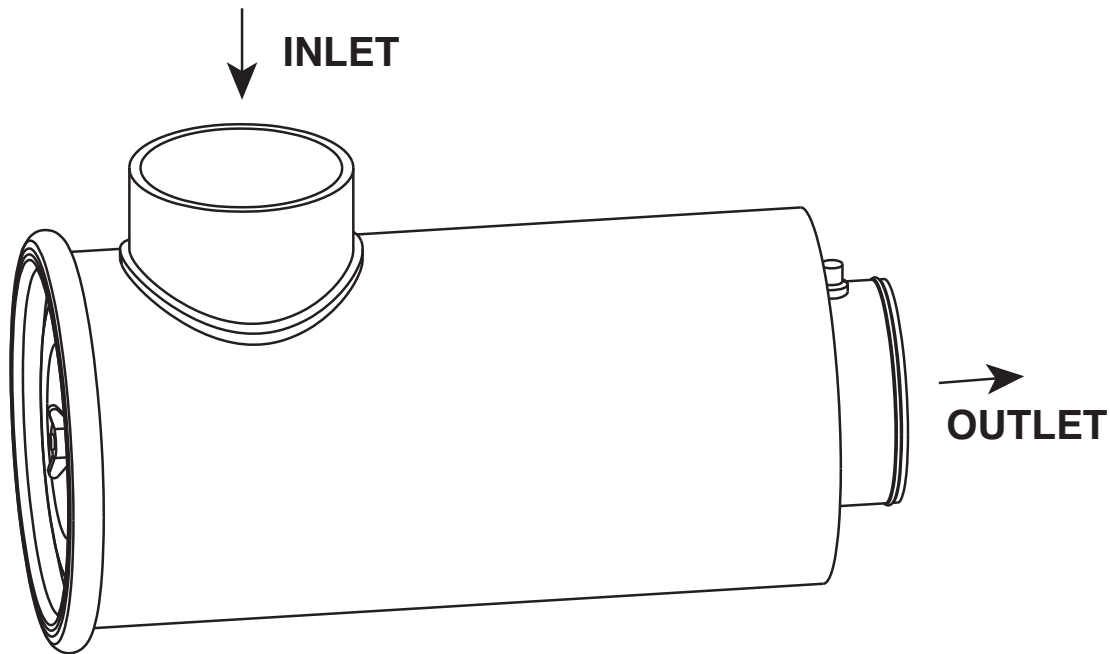

Specifications

Specification	AH19079
Length Overall	23.16" (585.7 mm)
Body OD	10.1" (256.5 mm)
Flow, Min. (2" Restriction)	465 CFM (13.2 m ³ /min)
Flow, Max. (12" Restriction)	1156 CFM (32.7 m ³ /min)
Secondary Element	No
Housing Material	Metal
Pre-cleaner Integral	No
Filter Efficiency	≥ 99.90% per ISO 5011

Dust Holding Capacity per Cummins® Specification

Specification	AH19079
Allowable Flow for 3 g/CFM	< 692 CFM (19.6 m ³ /min)
Allowable Flow for 10 g/CFM	< 329 CFM (9.3 m ³ /min)

Specifications subject to change without notice.

Ordering Information

Air Cleaner	
Part Number	Description
AH19079	Metal Air Cleaner

Accessories	
Part Number	Description
3918226S	Mounting Bracket
2	No. of Brackets Required
3316662S	Outlet Band Clamps
3918206S 3918207S	Weather Hood
3316612S	Hump-Hose
3316573S	90° Elbow
3316589S 3316590S	90° Reducing Elbow
3946326S	Restriction Indicator

Service Parts	
Part Number	Description
AF25548	Primary Element
N/A	Magnum Primary Element
N/A	Secondary Element
N/A	Dust Ejection Valve
3955488S 3955489S	Wing Nut/Clips
3955474S	Cover Assembly

Dimensions

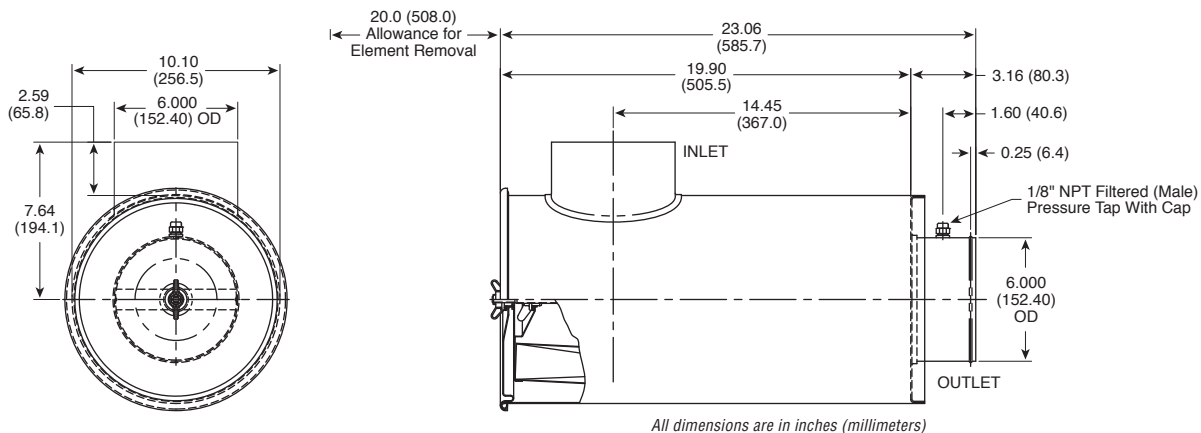

All dimensions are in inches (millimeters)

Performance

System Restriction vs Flow Rate

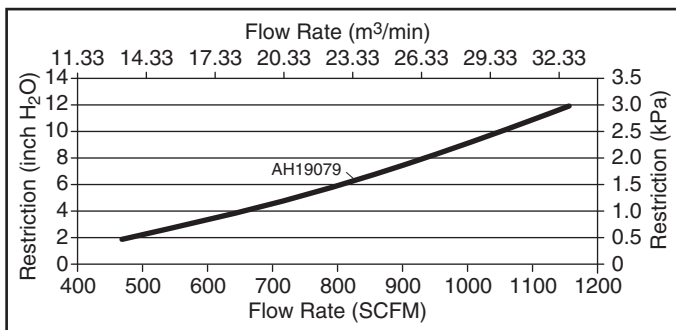

Typical System Capacity vs Flow Rate

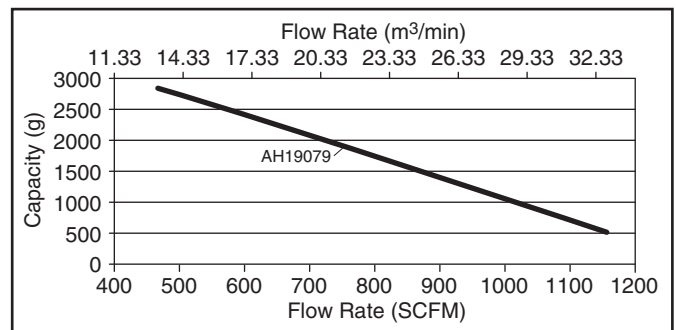

Restriction		Flow Rate		Typical Capacity
in H ₂ O	kPa	CFM	m³/min	grams
6	1.5	805	22.80	1697
8	2.0	935	26.48	1262
10	2.5	1051	29.76	874
12	3.0	1156	32.74	521

ISO Fine Dust
1.0 g/m³ Feed Rate
6.25 kPa (25" H₂O) Terminal Restriction



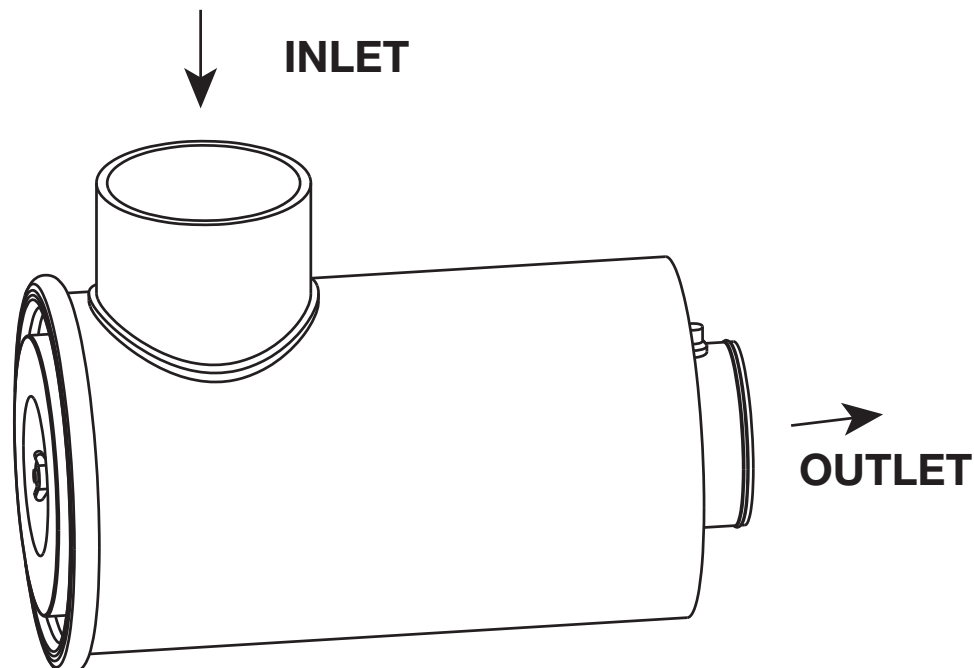

Specifications

Specification	AH19080
Length Overall	23.0" (583.2 mm)
Body OD	10.0" (255.0 mm)
Flow, Min. (2" Restriction)	470 CFM (13.3 m ³ /min)
Flow, Max. (12" Restriction)	1217 CFM (34.5 m ³ /min)
Secondary Element	No
Housing Material	Metal
Pre-cleaner Integral	No
Filter Efficiency	≥ 99.90% per ISO 5011

Dust Holding Capacity per Cummins® Specification

Specification	AH19080
Allowable Flow for 3 g/CFM	< 956 CFM (27.1 m ³ /min)
Allowable Flow for 10 g/CFM	< 473 CFM (13.4 m ³ /min)

Specifications subject to change without notice.

Ordering Information

Air Cleaner	
Part Number	Description
AH19080	Metal Air Cleaner

Accessories	
Part Number	Description
3918230S	Mounting Bracket
2	No. of Brackets Required
3316662S	Outlet Band Clamps
3918208S 3918209S	Weather Hood
3316612S	Hump-Hose
3316573S	90° Elbow
3316589S 3316590S	90° Reducing Elbow
3946326S	Restriction Indicator

Service Parts	
Part Number	Description
AF25549	Primary Element
N/A	Magnum Primary Element
N/A	Secondary Element
Q06316	Dust Ejection Valve
3955488 S 3955489 S	Wing Nut/Clips
3955475 S	Cover Assembly

Dimensions

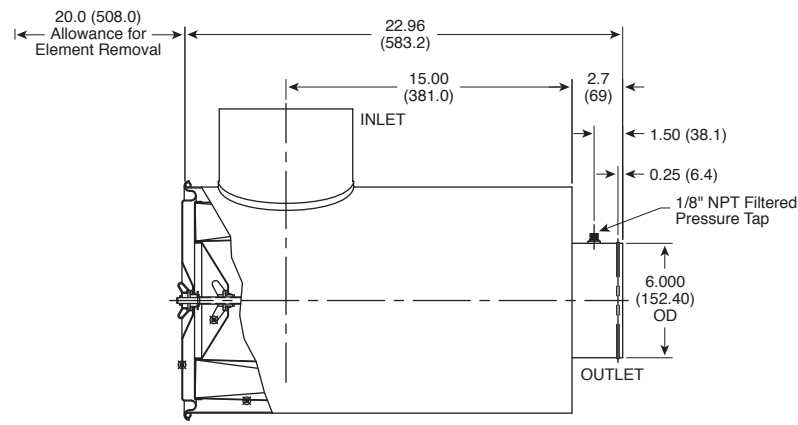
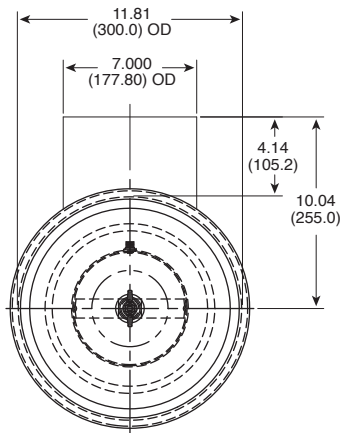

All dimensions are in inches (millimeters)

Performance

System Restriction vs Flow Rate

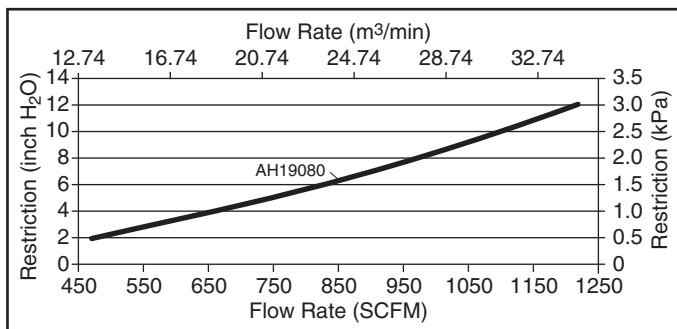

Typical System Capacity vs Flow Rate

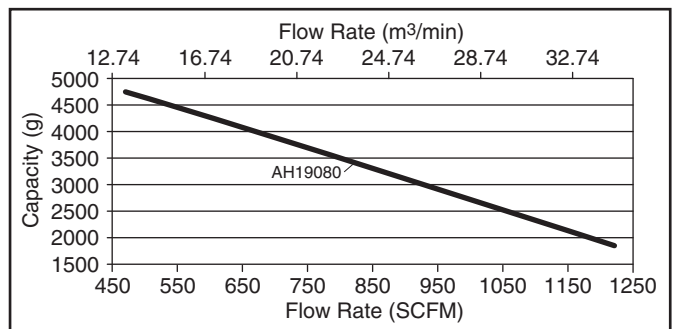

Restriction		Flow Rate		Typical Capacity
in H ₂ O	kPa	CFM	m³/min	grams
6	1.5	825	23.36	3374
8	2.0	968	27.41	2822
10	2.5	1098	31.10	2323
12	3.0	1217	34.47	1864

ISO Fine Dust
1.0 g/m³ Feed Rate
6.25 kPa (25" H₂O) Terminal Restriction



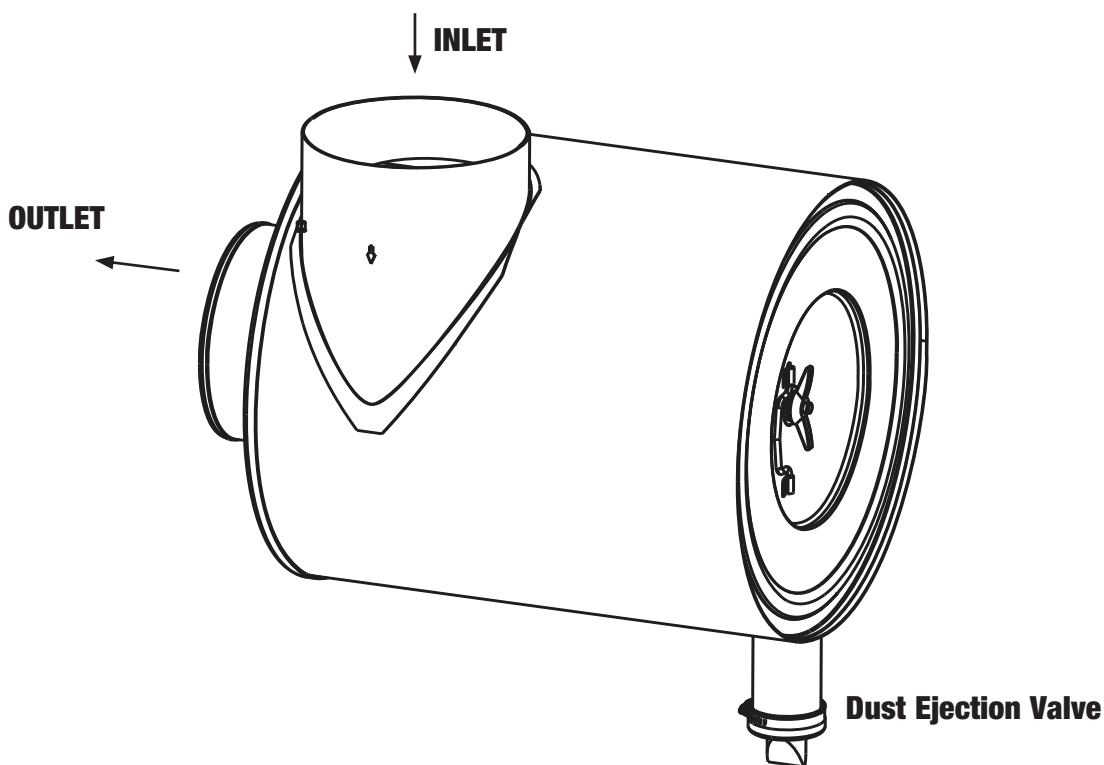

Specifications

Specification	AH19473
Length, Overall	28.4" (712.7 mm)
Width, Overall	21.4" (545.7 mm)
Height, Overall	30.5" (774.3 mm)
Flow, Min. (2" Restriction)	900 CFM (25.5 m ³ /min)
Flow, Max. (12" Restriction)	2330 CFM (66.0 m ³ /min)
Secondary Element	Yes
Housing Material	Metal
Pre-cleaner	Integral
Inlet	90° to Outlet, 10" (254.0 mm)
Filter Efficiency	≥ 99.90% per ISO 5011

Specifications subject to change without notice.

Dust Holding Capacity per Cummins® Specification

Specification	AH19473	
	CFM	m ³ /min
Allowable Flow for 10 g/CFM (357.1 g/m ³ /min)	2150	60.9
Allowable Flow for 25 g/CFM (892.9 g/m ³ /min)	1220	34.5

Ordering Information

Air Cleaner	
Part Number	Description
AH19473	Metal Air Cleaner - with Secondary Element

Accessories	
Part Number	Description
3940926S	Mounting Bracket
2	No. of Brackets Required
3316665S	Outlet Band Clamps
3940356S	Weather Hood
3316615S	Hump-Hose
3316578S	90° Elbow
3946326S	Restriction Indicator

Service Parts	
Part Number	Description
AF899	Primary Element
AF880	Secondary Element
Q06316	Dust Ejection Valve
AF899M	Magnum Primary Element
AF899NF	NanoFiber Primary Element

Dimensions

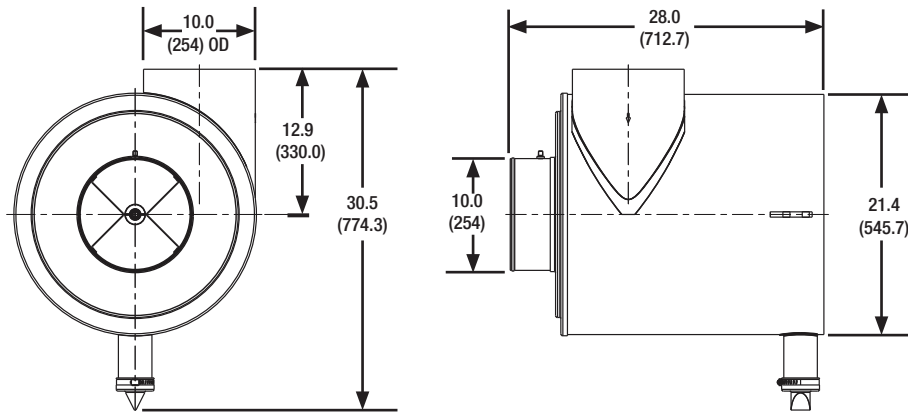

Performance

System Restriction vs Flow Rate

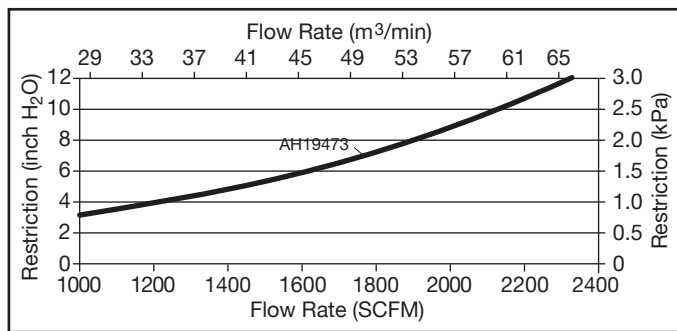

Typical System Capacity vs Flow Rate

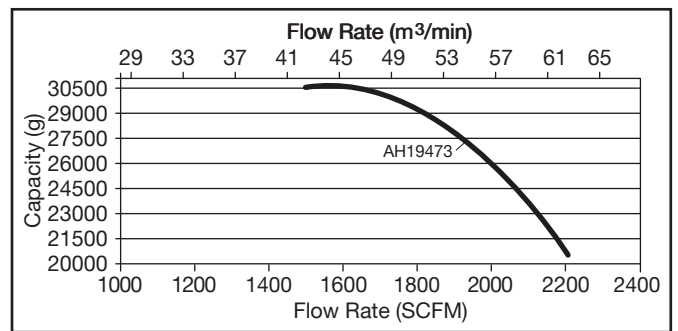

Restriction		Flow Rate		Typical Capacity
in H ₂ O	kPa	CFM	m ³ /min	grams
4	1.0	1256	35.6	30500
6	1.5	1623	46.0	30477
8	2.0	1906	54.0	27584
10	2.5	2144	60.7	22138
12	3.0	2330	66.0	15966

ISO Coarse Dust
2.0 g/m³ Feed Rate
6.25 kPa (25" H₂O) Terminal Restriction
per ISO 5011



Disposable Air Cleaners



Throw-Away Style

Features

- Disposable “Throw-Away” Plastic Housing
- Over 99% Efficiency
- Wide Range of Low to Medium Dust Concentration Applications
- Low Initial Cost
- Filter Elements Included

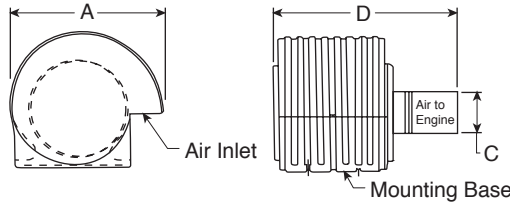

Part Number	Body Dia. in (mm) A	OD in (mm) C	Length in (mm) D	Airflow CFM			Airflow m ³ /min		
				6" H ₂ O	8" H ₂ O	10" H ₂ O	1.5 kPa	2.0 kPa	2.5 kPa
AH1100	17.4 (442)	5.5 (140)	14.6 (370)	700	820	920	19.8	23.2	26.0
AH1101	19.8 (503)	5.5 (140)	17.8 (453)	798	920	1040	22.6	26.0	29.4

ECB Style

Replaces Donaldson® ECB Duralite™ Style Disposable Housings and Filters

Applications

- Light and Medium Duty Engines
- Gas and Diesel Powered Vehicles and Equipment

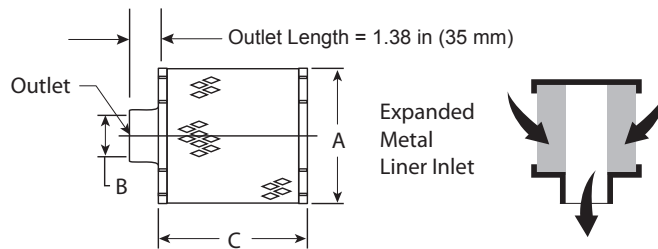

Part Number	Body Dia. in (mm) A	Outlet ID in (mm) B	Length in (mm) C	Airflow CFM			Airflow m ³ /min			Media Type*
				4" H ₂ O	6" H ₂ O	8" H ₂ O	1 kPa	1.5 kPa	2 kPa	
AH1136	8.5 (215.9)	3 (76.2)	11 (279.4)	275	335	390	7.79	9.49	11.04	A
AH1141	8.5 (215.9)	4 (101.6)	11 (279.4)	280	400	470	7.93	11.33	13.30	A
AH1185	8.5 (215.9)	3 (76.2)	3 (76.2)	83	124	150	2.36	3.52	4.24	A
AH1188	8.5 (215.9)	3 (76.2)	8.5 (215.9)	176	256	300	4.90	7.25	8.50	A
AH19002	8.5 (215.9)	4 (101.6)	11 (279.4)	280	400	470	7.93	11.33	13.30	B
AH19003	8.5 (215.9)	3 (76.2)	11 (279.4)	275	335	390	7.20	9.16	11.89	B
AH19004	10.5 (266.7)	4 (101.6)	10.5 (266.7)	380	440	480	10.76	12.46	13.59	B
AH19037	10.5 (266.7)	4 (101.6)	10.5 (266.7)	450	590	680	12.74	16.70	19.25	A
AH19042	12.5 (317.5)	6 (152.4)	15 (381.0)	500	650	800	14.15	18.40	22.65	C

* A = Standard
 B = Treated for higher humidity (marine applications, for example)
 C = Reinforced to withstand higher pulsation applications

ECC Style

Replaces Donaldson® ECC Duralite™ Style Disposable Housings and Filters

Applications

- Light and Medium Duty Engines
- Gas and Diesel Powered Vehicles and Equipment

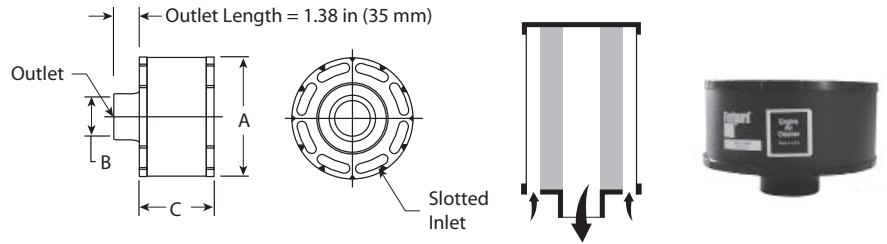

Part Number	Body Dia. in (mm) A	OD in (mm) B	Length in (mm) C	Airflow CFM			Airflow m³/min			Media Type
				4" H ₂ O	6" H ₂ O	8" H ₂ O	1 kPa	1.5 kPa	2 kPa	
AH1107	8.5 (215.9)	3 (76.2)	9.5 (241.35)	170	205	245	4.81	5.80	6.94	C
AH1138	8.5 (215.9)	3 (76.2)	5 (127.0)	150	180	215	4.25	5.10	6.09	C
AH1140	10.5 (266.7)	4 (101.6)	6 (152.4)	325	400	480	9.20	11.32	13.59	A
AH1190	8.5 (215.9)	2.5 (63.5)	6.5 (165.1)	130	165	188	3.68	4.67	5.32	C
AH1196	10.5 (266.7)	4 (101.6)	10.5 (266.7)	400	500	620	11.33	14.16	17.56	A
AH1198	8.5 (215.9)	2.5 (63.5)	4 (101.6)	112	145	170	3.17	4.11	4.81	C
AH1199	8.5 (215.9)	2.5 (63.5)	9.5 (241.3)	135	170	195	3.82	4.81	5.52	C
AH19000	5.5 (139.7)	1.75 (44.45)	4 (101.6)	64	82	94	1.81	2.32	2.66	C
AH19001	4.5 (114.3)	1.5 (38.1)	4.5 (114.3)	42	55	64	1.19	1.56	1.81	C
AH19220	12.5 (317.5)	5 (127.0)	11 (279.4)	485	620	760	13.73	17.55	21.52	A
AH19232	6.5 (165.1)	2 (50.8)	7.5 (190.5)	108	137	162	3.05	3.87	4.58	C

- * A = Standard
- B = Treated for higher humidity (marine applications, for example)
- C = Reinforced to withstand higher pulsation applications

ECD Style

Replaces Donaldson ECD Duralite Style Disposable Housings and Filters

Applications

- Light and Medium Duty Engines
- Gas and Diesel Powered Vehicles and Equipment

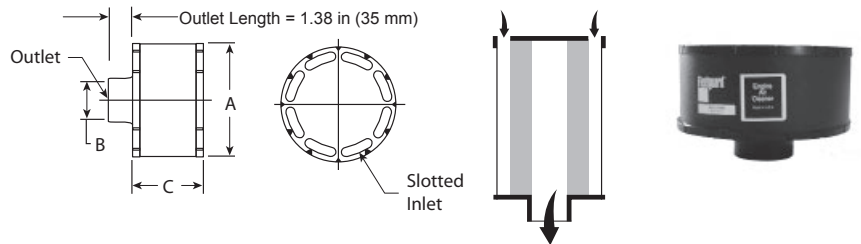

Part Number	Body Dia. in (mm) A	OD in (mm) B	Length in (mm) C	Airflow CFM			Airflow m³/min		
				4" H ₂ O	6" H ₂ O	8" H ₂ O	1.0 kPa	1.5 kPa	2.0 kPa
AH19228	4.5 (114.3)	1.5 (38.1)	4.5 (114.3)	44	56	65	1.24	1.58	1.84

ECO II Single-Stage Air Cleaner for Medium-Duty Service

Its unique, tapered, offset, and oversized element in a highly efficient, compact design makes the ECO II today's leading choice for many stationary engine applications. The revolutionary design results in greatly reduced intake air restriction, and provides maximum airflow to the engine.

Features

- 99.9% Efficiency



Component	Diameter in (mm)	Length in (mm)	Normal Rated Airflow CFM 8 in H ₂ O	Normal Rated Airflow m ³ /min 8 in H ₂ O	Intake Dia in (mm)	Outlet Dia in (mm)	Part Number
ECO II Air Cleaner	9.75 (248)	24 (610)	1100	–	Grid	6 (152)	AH1194
	11.0 (279)	24 (610)	1380	–	Grid	7 (178)	AH1103F/ AH1103
	13.5 (343)	15 (381)	1600	–	Grid	7 (178)	AH1195
	13.5 (343)	18 (457)	1600	–	Grid	7 (178)	AH1183
	13.5 (343)	24 (610)	1600	–	Grid	7 (178)	AH1135
Optional Inlet Adapter	9.75 (248)	–	–	–	6 (152)	–	3836943 S
	11.0 (279)	–	–	–	6 (152)	–	3836944 S
	11.0 (279)	–	–	–	7 (178)	–	3836945 S
	13.5 (343)	–	–	–	7 (178)	–	3836946 S
Combination Water Separator and Inlet Adapter	9.75 (248)	–	–	–	6 (152)	–	3836947 S
	11.0 (279)	–	–	–	6 (152)	–	3836948 S
	11.0 (279)	–	–	–	7 (178)	–	3836949 S
	13.5 (343)	–	–	–	7 (178)	–	3836950 S
Hose Clamps (2 Required)	9.75 (248)	–	–	–	–	–	3836951 S
	11.0 (279)	–	–	–	–	–	3836952 S
	13.5 (343)	–	–	–	–	–	3836953 S
Pressure Tap Sleeve (with Service Indicator) 1/8" NPT Tap	–	–	–	–	6 (152)	6 (152)	3836954 S
Pressure Tap Sleeve (with Service Indicator) 1/8" NPT and 3/4" NPT Taps	–	–	–	–	6 (152)	6 (152)	3836955 S
Pressure Tap Sleeve (with Service Indicator) 1/8" NPT Tap	–	–	–	–	7 (178)	7 (178)	3836956 S
Pressure Tap Sleeve (with Service Indicator) 1/8" NPT and 3/4" NPT Taps	–	–	–	–	7 (178)	7 (178)	3836957 S

ECO-SE For Light and Medium Duty Applications

The ECO-SE is perfect for today's smaller fleet and stationary engines up to 250 hp. Its compact size, light weight, ease of service, and high efficiency combine to provide the critical engine protection and simplified maintenance cost-conscious equipment operators now require.

Features

- Integral neoprene outlet for easy installation and service
- 99.9% efficiency



Component	Body Dia. in (mm) A	Outlet ID in (mm) B	Length in (mm) C	Airflow CFM			Airflow m ³ /min			Part Number
				4" H ₂ O	6" H ₂ O	8" H ₂ O	1.0 kPa	1.5 kPa	2.0 kPa	
ECO-SE Air Cleaner	6.8 (171.5)	3 (76.2)	14.16 (360)	240	300	330	6.80	8.50	9.63	AH1191
	7.8 (169.9)	4 (101.6)	17.16 (435)	355	440	510	10.05	12.50	14.44	AH1192
	9.7 (247.7)	5 (127.0)	20.16 (512)	610	760	890	17.27	21.52	25.20	AH1193
	9.7 (152.4)	5 (127.0)	19.40 (493)	600	840	900	16.99	23.78	25.50	AH1197

Component	Diameter in (mm)	Part Number
Mounting Clamps (2 Required)	6.75 (171.5)	3836931 S
	7.75 (169.9)	3836932 S
	9.75 (247.7)	3836933 S

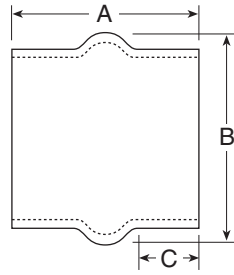

Hump Hoses

ID in (mm)	A in (mm)	B in (mm)	C in (mm)	Part Number
3.00 (76.20)	5.25 (133.35)	4.50 (114.30)	2.00 (50.80)	3316606 S
3.50 (88.90)	5.25 (133.35)	5.00 (127.00)	2.00 (50.80)	3316607 S
4.00 (101.60)	5.25 (133.35)	5.37 (136.40)	2.00 (50.80)	3316608 S
4.50 (114.30)	5.25 (133.35)	5.87 (149.10)	1.75 (44.45)	3316609 S
5.00 (127.00)	6.00 (152.40)	6.12 (155.45)	2.25 (57.15)	3316610 S
5.50 (139.70)	6.00 (152.40)	7.00 (177.80)	2.25 (57.15)	3316611 S
6.00 (152.40)	6.00 (152.40)	7.50 (190.50)	2.75 (69.85)	3316612 S
7.00 (177.80)	7.00 (177.80)	8.50 (215.90)	2.50 (63.50)	3316613 S
8.00 (203.20)	5.00 (127.00)	9.50 (241.30)	1.50 (38.10)	3316614 S
10.00 (254.00)	6.00 (152.40)	11.50 (292.10)	2.00 (50.80)	3316615 S

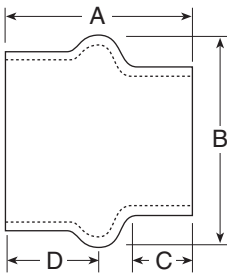

Hump Hose Reducers

ID in (mm)	A in (mm)	B in (mm)	C in (mm)	D in (mm)	Part Number
3.00 x 2.50 (76.20 x 63.50)	4.50 (114.30)	4.25 (107.95)	2.12 (53.85)	3.00 (76.20)	900012K
3.50 x 3.00 (88.90 x 76.20)	5.00 (127.00)	5.00 (127.00)	2.12 (53.85)	2.12 (53.85)	3316616 S
4.00 x 3.00 (101.60 x 76.20)	5.25 (133.35)	5.50 (139.70)	1.50 (38.10)	1.75 (44.45)	3316617 S
5.00 x 4.00 (127.00 x 101.60)	6.00 (152.40)	6.50 (165.10)	1.50 (38.10)	1.75 (44.45)	3316618 S
5.50 x 4.00 (139.70 x 101.60)	6.00 (152.40)	7.00 (177.80)	1.87 (47.50)	2.00 (50.80)	3316619 S
5.50 x 5.00 (139.70 x 127.00)	6.00 (152.40)	7.00 (177.80)	1.87 (47.50)	2.00 (50.80)	3316620 S
6.00 x 5.00 (152.40 x 127.00)	6.00 (152.40)	7.50 (190.50)	1.87 (47.50)	2.00 (50.80)	3316621 S
6.00 x 5.50 (152.40 x 139.70)	6.00 (152.40)	7.50 (190.50)	2.00 (50.80)	2.00 (50.80)	3316622 S
7.00 x 5.50 (177.80 x 139.70)	7.00 (177.80)	8.50 (215.90)	2.25 (57.15)	2.75 (69.85)	3316623 S
7.00 x 6.00 (177.80 x 152.40)	6.00 (152.40)	8.50 (215.90)	1.44 (36.58)	1.50 (38.10)	3316624 S
8.00 x 5.50 (203.20 x 139.70)	7.00 (177.80)	9.50 (241.30)	1.75 (44.45)	1.75 (44.45)	3316625 S
8.00 x 6.00 (203.20 x 152.40)	6.00 (152.40)	9.50 (241.30)	1.38 (35.05)	1.50 (38.10)	3316626 S
8.00 x 7.00 (203.20 x 177.80)	6.00 (152.40)	9.50 (241.30)	1.44 (36.58)	1.50 (38.10)	3316627 S
10.00 x 8.00 (254.00 x 203.20)	6.00 (152.40)	11.50 (292.10)	1.75 (44.45)	2.00 (50.80)	3316628 S

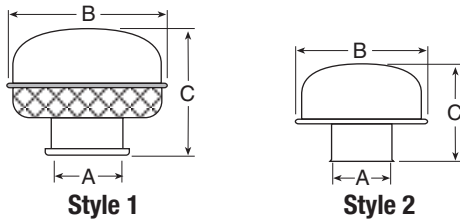

Style 1

Style 2

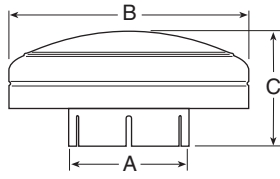

Style 3

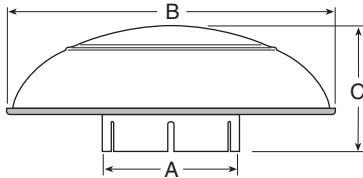

Style 4

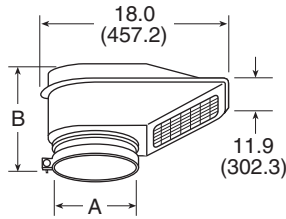

Style 5

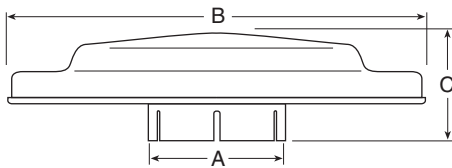

Style 6

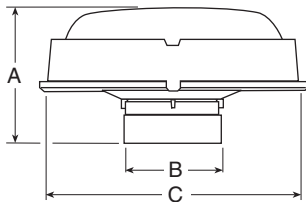

Style 7

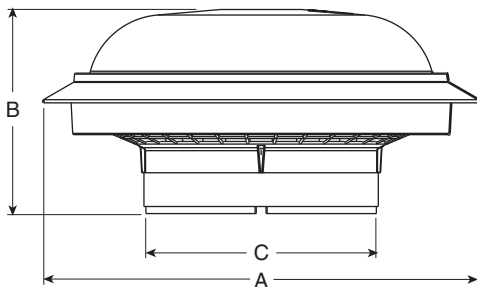

Style 8

Weather Hoods (Styles 1 – 6)

Style	A (ID) in (mm)	B in (mm)	C in (mm)	Material	Finish	Part Number
2	2.0 (50.8)	4.6 (116.8)	3.3 (83.8)	Metal	Black	3918200 S
2	2.5 (63.5)	5.8 (147.3)	3.9 (99.1)	Metal	Primer	3918201 S
2	3.0 (76.2)	6.6 (167.6)	5.0 (127.0)	Metal	Primer	3918202 S
1	3.7 (94.0)	9.5 (241.3)	8.0 (203.2)	Metal	Black	3918203 S
1	4.0 (101.6)	9.5 (241.3)	8.0 (203.2)	Metal	Black	3918204 S
3	5.0 (127.0)	9.5 (241.3)	5.0 (127.0)	Metal	Black	3918205 S
3	6.0 (152.4)	9.5 (241.3)	5.0 (127.0)	Metal	Black	3918206 S
6	6.0 (152.4)	13.0 (330.2)	4.1 (104.1)	Plastic	Stainless*	3918207 S
6	7.0 (177.8)	13.0 (330.2)	3.8 (96.5)	Plastic	Stainless*	3918208 S
4	7.0 (177.8)	17.0 (431.8)	6.8 (172.7)	Metal	Black	3918209 S
8	8.1 (205.0)	16.2 (412.0)	7.9 (200.0)	Metal	Black	3940357 S
3	10.0 (254.0)	19.2 (487.7)	7.9 (200.7)	Metal	Black	3940356 S

* Stainless cap is polished to match chrome appearance.

Weather Hoods (Style 5)

Style	A (ID) in (mm)	B in (mm)	Part Number	
			Black Finish	Chrome Finish
5	5.5 (139.7)	9.6 (244.6)	3918210 S	3918214 S
5	6.0 (152.4)	9.5 (241.3)	3918211 S	3918215 S
5	7.0 (177.8)	9.3 (236.5)	3918212 S	3918216 S
5	8.0 (203.2)	8.1 (206.4)	3918213 S	3918217 S

Weather Hoods (Style 7, Composite)

Style	B (ID) in (mm)	C in (mm)	A in (mm)	Part Number
7	1.75 (44.45)	5.51 (139.95)	2.81 (71.37)	3918195 S
7	2.00 (50.80)	5.54 (140.72)	2.86 (72.64)	3918194 S
7	2.50 (63.50)	5.54 (140.72)	2.86 (72.64)	3918193 S

Weather Hoods (Style 8, Composite)

Style	C (ID) in (mm)	A in (mm)	B (ID) in (mm)	Part Number
8	3.00 (76.20)	8.00 (203.20)	3.75 (95.25)	3946322 S
8	3.75 (95.25)	8.00 (203.20)	3.75 (95.25)	3946458 S
8	4.50 (114.30)	13.50 (342.90)	4.98 (126.49)	3946464 S
8	5.00 (127.00)	13.50 (342.90)	4.87 (123.70)	3946466 S
8	6.00 (152.40)	11.57 (293.88)	5.15 (130.81)	3949015 S
8	7.00 (177.80)	13.50 (342.90)	4.45 (113.03)	3946468 S

Metal Mounting Brackets

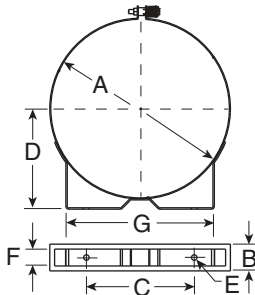

A in (mm)	B in (mm)	C in (mm)	D in (mm)	E in (mm)	F in (mm)	Part Number
4.40 (111.76)	0.88 (22.35)	4.00 (101.6)	2.50 (63.50)	0.344 (8.74)	0.50 (12.70)	3918218 S
5.25 (133.35)	0.88 (22.35)	3.25 (82.55)	3.12 (79.25)	0.344 (8.74)	0.50 (12.70)	3918219 S
6.50 (165.10)	0.88 (22.35)	3.75 (95.25)	3.75 (95.25)	0.344 (8.74)	0.50 (12.70)	3918220 S
7.30 (185.42)	0.88 (22.35)	4.25 (107.95)	4.15 (105.41)	0.344 (8.74)	0.50 (12.70)	3918221 S
7.89 (200.41)	0.88 (22.35)	4.25 (107.95)	4.44 (112.78)	0.344 (8.74)	0.50 (12.70)	3918222 S
8.00 (203.20)	1.25 (31.75)	4.25 (107.95)	4.88 (123.95)	0.406 (10.31)	0.88 (22.35)	3918223 S
8.50 (215.90)	0.88 (22.35)	4.25 (107.95)	4.75 (120.65)	0.344 (8.74)	0.50 (12.70)	3918224 S
9.00 (228.60)	1.25 (31.75)	4.50 (114.30)	5.38 (136.65)	0.406 (10.31)	0.88 (22.35)	3918225 S
10.20 (259.08)	1.25 (31.75)	5.00 (127.00)	5.98 (151.89)	0.406 (10.31)	0.88 (22.35)	3918226 S
10.30 (261.62)	1.25 (31.75)	5.00 (127.00)	6.03 (153.16)	0.406 (10.31)	0.88 (22.35)	3918227 S
11.00 (279.40)	1.25 (31.75)	5.00 (127.00)	6.38 (162.05)	0.406 (10.31)	0.88 (22.35)	3918228 S
11.00 (279.40)	1.25 (31.75)	5.00 (127.00)	6.38 (162.05)	0.406 (10.31)	0.88 (22.35)	3918229 S*
11.80 (299.72)	1.25 (31.75)	6.00 (152.40)	6.78 (172.21)	0.406 (10.31)	0.88 (22.35)	3918230 S
12.10 (307.34)	1.50 (38.10)	8.00 (203.20)	7.12 (180.85)	0.469 (11.91)	1.06 (26.92)	3918231 S
13.00 (330.20)	1.50 (38.10)	6.00 (152.40)	7.56 (192.02)	0.469 (11.91)	1.06 (26.92)	3918232 S*
13.00 (330.20)	1.50 (38.10)	6.00 (152.40)	7.56 (192.02)	0.469 (11.91)	1.06 (26.92)	3918233 S
14.00 (355.60)	1.50 (38.10)	8.00 (203.20)	8.06 (204.72)	0.469 (11.91)	1.06 (26.92)	3918234 S
15.00 (381.00)	1.25 (31.75)	8.00 (203.20)	8.38 (212.85)	0.406 (10.31)	0.88 (22.35)	3918235 S
16.00 (406.40)	1.25 (31.75)	10.00 (254.00)	8.88 (225.55)	0.406 (10.31)	0.88 (22.35)	3918236 S
18.10 (459.74)	1.50 (38.10)	8.00 (203.20)	10.12 (257.05)	0.469 (11.91)	1.06 (26.92)	3918237 S
21.48 (545.70)	1.97 (50.00)	19.37 (492.00)	10.98 (278.85)	0.551 (14.00)	1.97 (50.00)	3940926 S

* = Stainless Steel

Wire Form Brackets for Plastic Air Cleaners

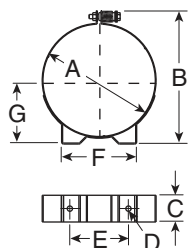

Style	For Use On	A in (mm)	Bolt Hole Diameter in (mm)	Part Number
2	OptiAir™ 400 Series	4.63 (117.6)	0.35 (9.0)	3956074 S
1	OptiAir 400 Series	4.63 (117.6)	0.35 (9.0)	3956073 S
2	OptiAir 500 Series	5.62 (142.8)	0.35 (9.0)	3956075 S
1	OptiAir 500 Series	5.62 (142.8)	0.35 (9.0)	3956076 S

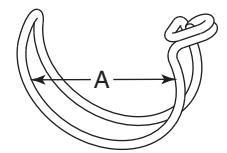

Style 1

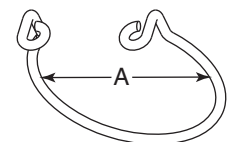

Style 2

Mounting Brackets for Plastic Air Cleaners

For Use On	A in (mm)	B in (mm)	C in (mm)	D in (mm)	E in (mm)	F in (mm)	G in (mm)	Part Number
4" & OptiAir™ 400 Series	4.77 (121.16)	6.45 (163.83)	1.57 (39.88)	.35 (8.89)	2.76 (70.10)	4.00 (101.60)	3.07 (77.98)	3918199 S
5" & OptiAir 500 Series	5.72 (145.20)	7.39 (187.71)	1.98 (50.29)	.35 (8.89)	3.15 (80.01)	4.38 (111.25)	3.54 (89.92)	3918198 S
6" & OptiAir 600 Series	6.50 (165.10)	8.32 (211.33)	1.98 (50.29)	.35 (8.89)	3.54 (89.92)	4.75 (120.65)	3.95 (100.33)	3918196 S
7" Mounting Bracket	7.17 (182.12)	8.74 (222.00)	1.98 (50.29)	.35 (8.89)	3.94 (100.08)	5.25 (133.35)	4.15 (105.41)	3955477 S
8" & OptiAir 800 Series	8.32 (211.33)	9.88 (250.95)	1.98 (50.29)	.35 (8.89)	4.34 (110.24)	5.56 (141.22)	4.72 (119.98)	3918197 S
10" & OptiAir 1000 Series	9.83 (249.68)	11.68 (296.67)	1.25 (31.75)	.406 (10.31)	6.00 (152.40)	8.50 (215.90)	5.78 (146.81)	3946456 S
11" & OptiAir 1100 Series	11.35 (288.29)	13.16 (334.26)	1.25 (31.75)	.406 (10.31)	6.50 (165.10)	8.50 (215.90)	6.50 (165.10)	3932495 S
13" & OptiAir 1300 Series	13.23 (336.04)	15.07 (382.78)	1.25 (31.75)	.406 (10.31)	8.00 (203.20)	11.00 (279.40)	8.00 (203.20)	3936445 S

Hose Clamps • Dust Ejection Valves Air Intake Components

Hose Clamps

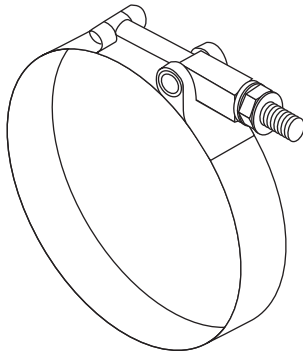

Nominal Connection* in (mm)	Actual Clamp ID in (mm)	Part Number
2.0 (50.8)	2.25 - 2.50 (57.15 - 63.50)	3316653 S
2.5 (63.5)	2.75 - 3.06 (69.85 - 77.72)	3316654 S
3.0 (76.2)	3.25 - 3.56 (82.55 - 90.42)	3316656 S
3.5 (88.9)	3.75 - 4.06 (95.25 - 103.12)	3316657 S
4.0 (101.6)	4.25 - 4.56 (107.95 - 115.82)	3316658 S
4.5 (114.3)	4.75 - 5.06 (120.65 - 128.52)	3316659 S
5.0 (127.0)	5.25 - 5.56 (133.35 - 141.22)	3316660 S
5.5 (139.7)	5.75 - 6.06 (146.05 - 153.92)	3316661 S
6.0 (152.4)	6.38 - 6.69 (162.05 - 169.93)	3316662 S
7.0 (177.8)	7.25 - 7.76 (184.15 - 197.10)	3316663 S
8.0 (203.2)	8.50 - 8.81 (215.90 - 223.77)	3316664 S
10.0 (254.0)**	10.50 - 11.00 (266.70 - 279.40)	3316665 S
10.0 (254.0)***	10.25-10.75 (260.35-273.05)	3316666 S

* Nominal ID dimension shown corresponds to ID dimension of rubber part being clamped.

** For use with 45° and 90° Elbows.

*** For use with Hump Hoses and Reducers.

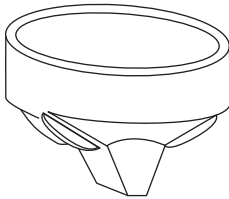

Dust Ejection Valves

Size in (mm)	For Use On	Part Number
1.5 (38.1)	Plastic and Metal	3946457 S
3.0 (76.2)	Metal Only	Q06316

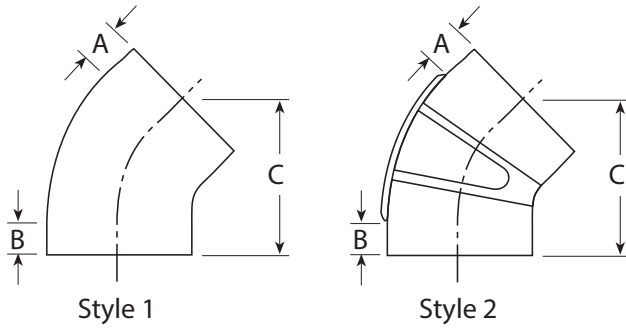

45° Elbows

Part Number	ID in (mm)	OD in (mm)	A in (mm)	B in (mm)	C in (mm)	Thickness in (mm)	Style
3316579 S	3.00 (76.2)	3.50 (88.9)	1.60 (40.6)	1.60 (40.6)	5.50 (139.7)	0.25 (6.4)	1
3316580 S	3.50 (88.9)	4.00 (101.6)	1.68 (42.7)	1.68 (42.7)	5.00 (127.0)	0.25 (6.4)	1
3316581 S	4.00 (101.6)	4.50 (114.3)	1.46 (37.1)	1.46 (37.1)	5.50 (139.7)	0.25 (6.4)	1
3316583 S	5.00 (127.0)	5.50 (139.7)	1.36 (34.5)	1.36 (34.5)	5.50 (139.7)	0.25 (6.4)	1
3316584 S	5.50 (139.7)	6.00 (152.4)	1.70 (43.2)	1.70 (43.2)	6.25 (158.8)	0.25 (6.4)	1
3316585 S	6.00 (152.4)	6.50 (165.1)	1.74 (44.2)	1.74 (44.2)	6.50 (165.1)	0.25 (6.4)	2
3316586 S	7.00 (177.8)	7.62 (193.6)	2.38 (60.5)	2.38 (60.5)	8.00 (203.2)	0.31 (7.9)	2
3316587 S	8.00 (203.2)	8.75 (222.3)	2.00 (50.8)	2.00 (50.8)	8.06 (204.7)	0.38 (9.7)	2
3316588 S	10.00 (254.0)	10.75 (273.1)	2.25 (57.2)	2.25 (57.2)	10.50 (266.7)	0.37 (9.4)	2

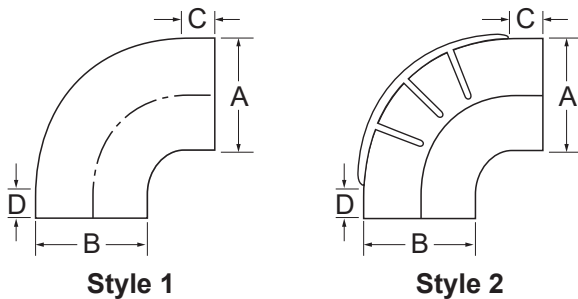

90° Elbows

Part Number	ID in (mm)	OD in (mm)	A in (mm)	B in (mm)	C in (mm)	D in (mm)	Thickness in (mm)	Style
3316564 S	2.00 (50.8)	2.40 (61.0)	3.50 (88.9)	3.50 (88.9)	1.50 (38.1)	1.50 (38.1)	0.20 (5.1)	1
3316565 S	2.50 (63.5)	3.00 (76.2)	4.00 (101.6)	4.00 (101.6)	1.50 (38.1)	1.50 (38.1)	0.25 (6.4)	1
3316566 S	3.00 (76.2)	3.50 (88.9)	5.25 (133.4)	5.25 (133.4)	1.50 (38.1)	1.50 (38.1)	0.25 (6.4)	1
3316567 S	3.50 (88.9)	4.00 (101.6)	5.50 (139.7)	5.50 (139.7)	1.50 (38.1)	1.50 (38.1)	0.25 (6.4)	1
3316568 S	4.00 (101.6)	4.50 (114.3)	5.75 (146.1)	5.75 (146.1)	1.25 (31.8)	1.25 (31.8)	0.25 (6.4)	1
3316569 S	4.50 (114.3)	5.00 (127.0)	5.50 (139.7)	5.50 (139.7)	2.0 (50.8)	2.0 (50.8)	0.25 (6.4)	1
3316570 S	5.00 (127.0)	5.50 (139.7)	6.12 (155.4)	6.12 (155.4)	1.62 (41.2)	1.62 (41.2)	0.25 (6.4)	1
3316571 S	5.50 (139.7)	6.00 (152.4)	6.50 (165.1)	6.50 (165.1)	1.75 (44.5)	1.75 (44.5)	0.25 (6.4)	2
3316573 S	6.00 (152.4)	6.50 (165.1)	6.75 (171.5)	6.75 (171.5)	1.75 (44.5)	1.75 (44.5)	0.25 (6.4)	2
3316576 S	7.00 (177.8)	7.62 (193.6)	7.56 (192.0)	7.56 (192.0)	2.00 (50.8)	2.00 (50.8)	0.31 (7.9)	2
3316577 S	8.00 (203.2)	8.76 (222.5)	8.50 (215.9)	8.50 (215.9)	2.00 (50.8)	2.00 (50.8)	0.38 (9.7)	2
3316578 S	10.00 (254.0)	10.74 (273.0)	10.50 (266.7)	10.50 (266.7)	2.00 (50.8)	2.00 (50.8)	0.37 (9.4)	2

Reducing Elbows

Air Intake Components

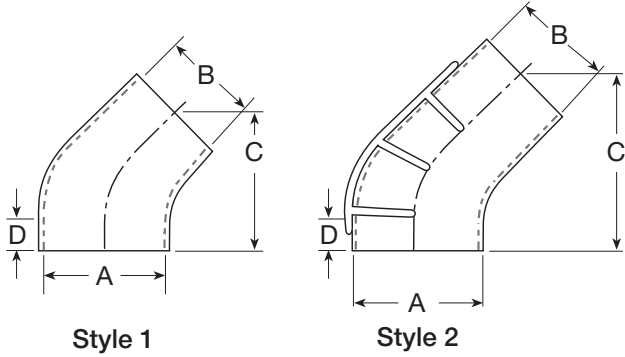

Reducing 45° Elbows

Part Number	A (ID) in (mm)	B (ID) in (mm)	C in (mm)	D in (mm)	Thickness in (mm)	Style
3316594 S	6.00 (152.4)	5.00 (127.0)	6.44 (163.6)	1.75 (44.4)	0.25 (6.4)	1
3316595 S	7.00 (177.8)	6.00 (152.4)	7.38 (187.4)	2.00 (50.8)	0.31 (7.9)	2

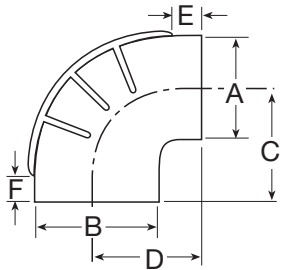

Reducing 90° Elbows

Part Number	A (ID) in (mm)	B (ID) in (mm)	C in (mm)	D in (mm)	E in (mm)	F in (mm)	Thickness in (mm)
3316589 S	5.00 (127.0)	6.00 (152.4)	7.00 (177.8)	6.00 (152.4)	1.75 (44.5)	1.75 (44.5)	0.25 (6.4)
3316590 S	5.50 (139.7)	6.00 (152.4)	6.75 (171.5)	6.75 (171.5)	1.75 (44.5)	1.5 (38.1)	0.25 (6.4)
3316591 S	5.00 (127.0)	7.00 (177.8)	7.00 (177.8)	6.25 (158.8)	1.75 (44.5)	2.74 (69.6)	0.25 (6.4)
3316592 S	5.50 (139.7)	7.00 (177.8)	5.75 (146.1)	6.25 (158.8)	1.50 (38.1)	1.50 (38.1)	0.31 (7.9)
3316593 S	6.00 (152.4)	7.00 (177.8)	7.56(192.0)	9.00 (228.6)	3.00 (76.2)	3.00 (76.2)	0.38 (9.7)
3940929 S	7.00 (177.8)	8.00 (203.2)	8.50 (215.9)	8.50 (215.9)	2.00 (50.8)	2.00 (50.8)	0.42 (10.7)

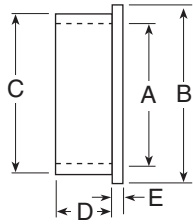

Reducer Inlet Sleeves

A in (mm)	B in (mm)	C in (mm)	D in (mm)	E in (mm)	Part Number
2.25 (57.15)	3.50 (88.90)	3.00 (76.20)	1.00 (25.40)	0.25 (6.35)	3930225 S
2.00 (50.80)	3.50 (88.90)	3.00 (76.20)	1.00 (25.40)	0.25 (6.35)	3930200 S
3.75 (95.25)	4.50 (114.30)	4.00 (101.60)	1.50 (38.10)	0.25 (6.35)	3940375 S
4.00 (101.60)	5.00 (127.00)	4.50 (114.30)	1.50 (38.10)	0.25 (6.35)	3945400 S
4.50 (114.30)	5.50 (139.70)	5.00 (127.00)	1.50 (38.10)	0.25 (6.35)	3950450 S
5.00 (127.00)	6.00 (152.40)	5.50 (139.70)	1.50 (38.10)	0.25 (6.35)	3316631 S
5.00 (127.00)	6.50 (165.10)	6.00 (152.40)	1.50 (38.10)	0.50 (12.70)	3316632 S
5.50 (139.70)	6.50 (165.10)	6.00 (152.40)	1.50 (38.10)	0.25 (6.35)	*3316633 S

* This part has been discontinued

Restriction Indicators

Take the uncertainty and extra costs out of air filter maintenance. A Restriction Indicator automatically and continually monitors the condition of your air filters.

The best preventative engine maintenance practice would be to ensure that air filters are only replaced when necessary. Changing a filter more often than necessary increases the risk of dirt reaching the engine. The disturbed dust can enter the intake near the filter sealing gasket area within the housing as the old filter is removed. Most of the dust that passes through a new air filter occurs in the first third of its useful life. Changing a filter too early doesn't utilize the best dirt removal efficiency, which occurs in the last two thirds of its service life.

Features

- Constant restriction readings allow accurate checks on filter restriction, even after shutdown
- Eliminates air cleaner over-servicing
- Saves fuel – Saves costs
- Reduces the chance of engine failure due to dirt entering the system
- Easy and safe to use
- Quick to install
- Manual reset

Single Position Indicator



Single Position Indicator with Electrical Switch



Graduated Indicator



Graduated Indicator with Electrical Switch



Type	Inches of H ₂ O	kPa	Height in (mm)	Port Size in (mm)	Part Number
Single Position	20	5.00	1.8 (46)	0.125 (3.18)	3946324 S
	25	6.35	1.8 (46)	0.125 (3.18)	3946326 S
Single Position with Electrical Switch	25	6.35	2.3 (59)	0.125 (3.18)	3946327 S
Graduated	20	5.00	2.7 (70)	0.125 (3.18)	3946273 S
	25	6.35	2.7 (70)	0.125 (3.18)	3946328 S
Graduated with Electrical Switch	25	6.35	3.1 (79)	0.125 (3.18)	3946329 S



Non-Locking Electrical Air Switch

This Restriction Indicator with an electrical switch can turn a light on within the vehicle when the restriction reaches a level where the filter should be changed. No reset switch is required since the light turns off automatically when the air flow and restriction decrease.

Part Number

3951083 S

Remote Mount Kit

(Not Shown) Includes a 30" (762 mm) hose, male and female barb fittings, and a plastic mount bracket. This kit can be used with any of the Restriction Indicators shown here.

Part Number

3951084 S





Pre-Cleaners

Maintenance-Free

Single-Stage
& Dual-Stage



Pre-Cleaners



- Extended air filter life
- Increased engine protection
- Reduced downtime
- Reduced maintenance costs
- Self-cleaning
- Lightweight
- Easy to install
- Durable polymer design

The Benefits of Fleetguard Pre-Cleaners

Fleetguard Pre-Cleaners are state-of-the-art products that reduce maintenance costs and downtime for all diesel applications. They are recommended for the construction, farming, mining, forestry or any other segment where operating conditions are severe. Fleetguard Pre-Cleaners keep air filters clean, extend the life of the filter and maintain engine performance. Positioned at the beginning of the air intake, Fleetguard air Pre-Cleaners eject the majority of dust/dirt particles that are heavier than air.

How the Fleetguard Pre-Cleaner Works

- 1** Dirty air passes through prescreen and enters through recessed vanes at the bottom of the Fleetguard Pre-Cleaner.
- 2** The curved particle accelerator rotates much faster than the incoming air, capturing debris, which is passed down the length of the particle accelerator's straked vanes.
- 3** The debris is then deposited on the inner wall of the separator chamber.
- 4** As the particle accelerator spins, it sweeps debris that has deposited under the strakes onto the inner wall of the pre-cleaner, where it is ejected.
- 5** Clean air continues to spin upward, being compressed, and forced into the air inlet opening.

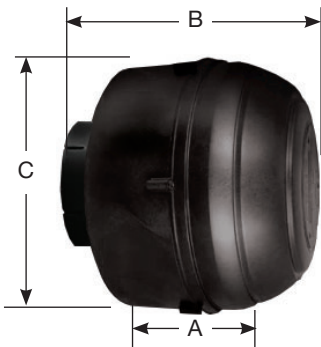
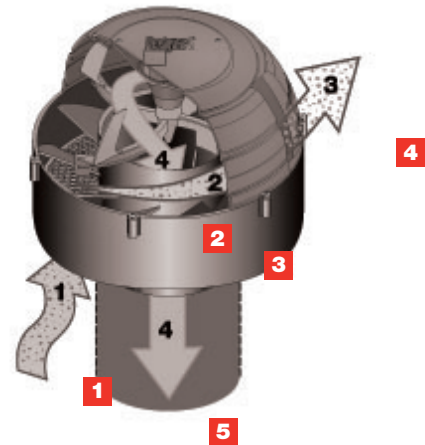

To properly size a Fleetguard Pre-Cleaner, you will need to know the correct airflow of the engine in CFM (m^3/min) and the Outside Diameter (OD) of the air intake. For optimum efficiency, select the pre-cleaner where the CFM (m^3/min) falls in the upper end of the ranges shown. **Do not size a Fleetguard Pre-Cleaner solely based on the air intake dimension.**

Pre-cleaners should not be mounted against any part of the machine as space is needed to allow air to enter into the pre-cleaner. Cummins Filtration® does not recommend putting pre-cleaners high in the air on an extended pipe as the further away the air intake is from the engine, the more added restriction.

Ordering Information

Single-Stage

Part Number	Outlet OD in (mm)	Width in (mm)	Height in (mm)	Flow Rate	
				CFM	m ³ /min
AP8407	2 (50.8)	4.5 (114.3)	3 (76.2)	10 - 50	0.28 - 1.42
AP8408	3 (76.2)	6.7 (170.18)	4.2 (106.68)	50 - 120	1.42 - 3.40
AP8403	4 (101.6)	8.5 (215.9)	6.28 (159.51)	100 - 275	2.83 - 7.79
AP8409	4 (101.6)	8.5 (215.9)	6.28 (159.51)	275 - 350	7.79 - 9.91
AP8421	5 (127.0)	10.6 (270)	7.9 (201)	350-500	9.91 - 14.16
AP8404	6 (152.4)	13.1 (332.74)	11.1 (281.94)	500 - 650	14.16 - 18.41
AP8410	6 (152.4)	13.1 (332.74)	11.1 (281.94)	650 - 800	18.41 - 22.65
AP8405	8 (203.2)	18 (457.2)	14.44 (366.776)	800 - 1150	22.65 - 32.56
AP8406	8 (203.2)	18 (457.2)	14.44 (366.776)	1150 - 1400	32.56 - 39.64

Dual-Stage

Fleetguard PN	Stage 1 PN	Stage 2 Inlet Diameter (inches)	Landfill Screen	Aspiration Tube and Check Valve	Ejector Port Angle (Degrees)	Mounting Flange Description	Purposed Application
AP85041	AP8404	6	X	X	--	--	CAT D6R and D6H
AP85042		6	X	X	--	--	CAT D7R and D7H
AP85043		6			--	Upper	Universal
AP85044		6			--	Lower	Universal
AP85046		6	X		--	Lower	Universal
AP85047		6	X		--	Upper	Universal
AP85101	AP8410	6			0.0	Upper	Universal
AP85102		6			15.0	Lower	Universal
AP85104		6	X		0.0	--	Universal
AP85105		6	X		15.0	Lower	Universal
AP85051	AP8405	7	X	X	20.0	--	CAT D8R and D8H
AP85052		7			32.5	Upper	Universal
AP85053		7	X	X	0.0	--	CAT D9R and D9N
AP85054		7			15.0	Lower	Universal
AP85055		7	X		32.5	Upper, Dual Stage	CAT 826G
AP85057		7	X		15.0	Lower	Universal
AP85058		7	X		32.5	Upper	Universal
AP85152		6	X	X	50.0	--	CAT D8N
AP85154		13	X		0.0	Lower, V-Clamp	CAT 836G
AP85163		AP8406	7	X		15.0	Lower
AP85061	7		X	X	15.0	--	CAT 836G
AP85062	7		X		32.5	Upper	Universal
AP85063	7				32.5	Upper	Universal
AP85064	7				15.0	Lower	Universal

*Flow rate of Dual-Stage Pre-Cleaner will perform in the same flow range as the Single-Stage Pre-Cleaner (Stage 1 PN)

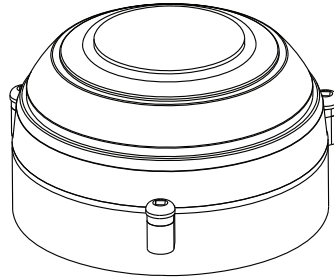

Specifications

Specification	AP8407
Width, Overall	4.4" (Ø 112.6 mm)
Height, Overall	3.0" (76.3 mm)
Application Flow Rate	10-50 CFM (0.28-1.42 m ³ /min)
Outlet tube	2" (Ø 51.6 mm I.D.)

Specifications subject to change without notice.

Dimensions

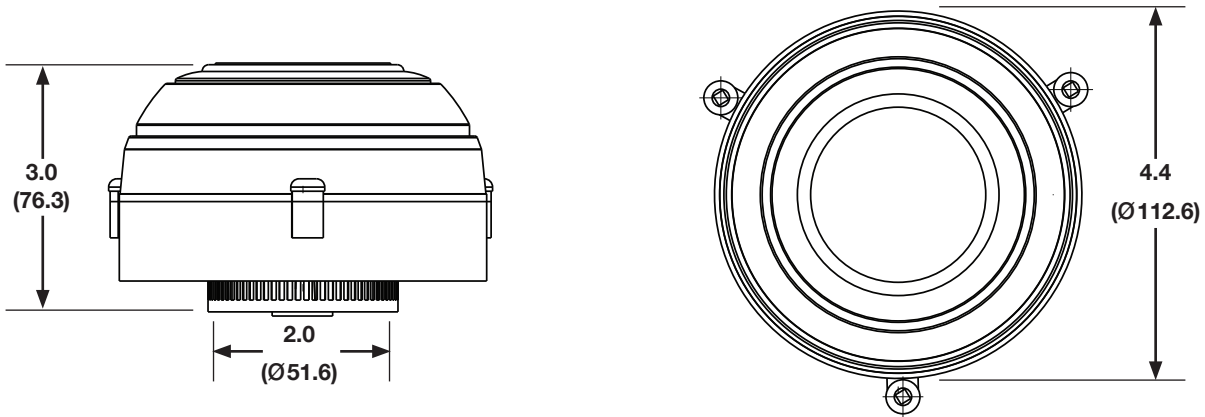

All dimensions are in inches (millimeters).

Ordering Information

Single-Stage Pre-Cleaner	
Part Number	Description
AP8407	Pre-Cleaner

Performance

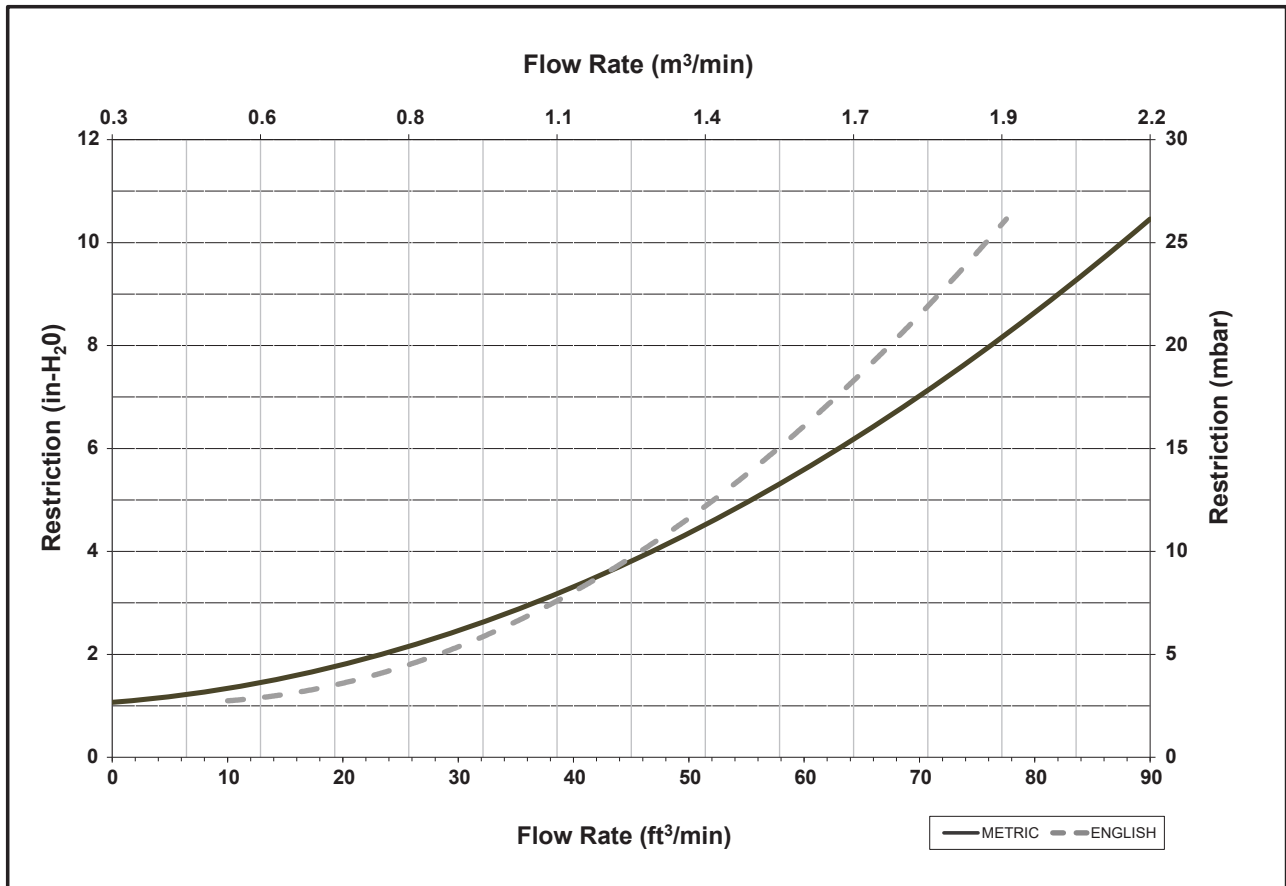

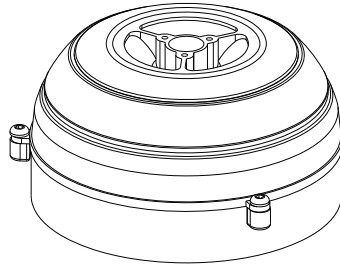

Specifications

Specification	AP8408
Width, Overall	6.7" (Ø169.9 mm)
Height, Overall	4.2" (108.2 mm)
Application Flow Rate	50-120.CFM (1.42-3.40 m³/min)
Outlet tube	3.0" (Ø 77.0 mm I.D.)

Specifications subject to change without notice.

Dimensions

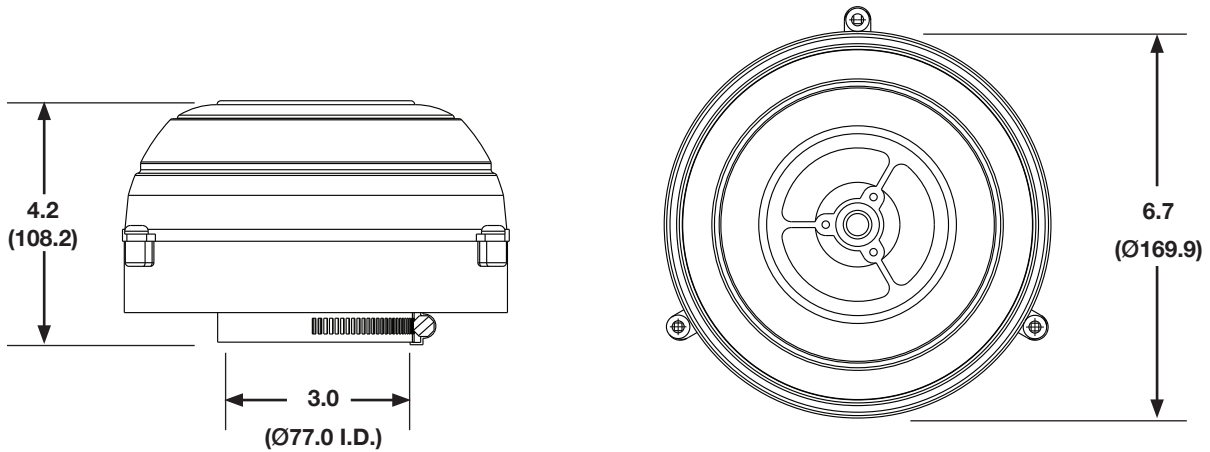

All dimensions are in inches (millimeters).

Ordering Information

Single-Stage Pre-Cleaner	
Part Number	Description
AP8408	Pre-Cleaner

Performance

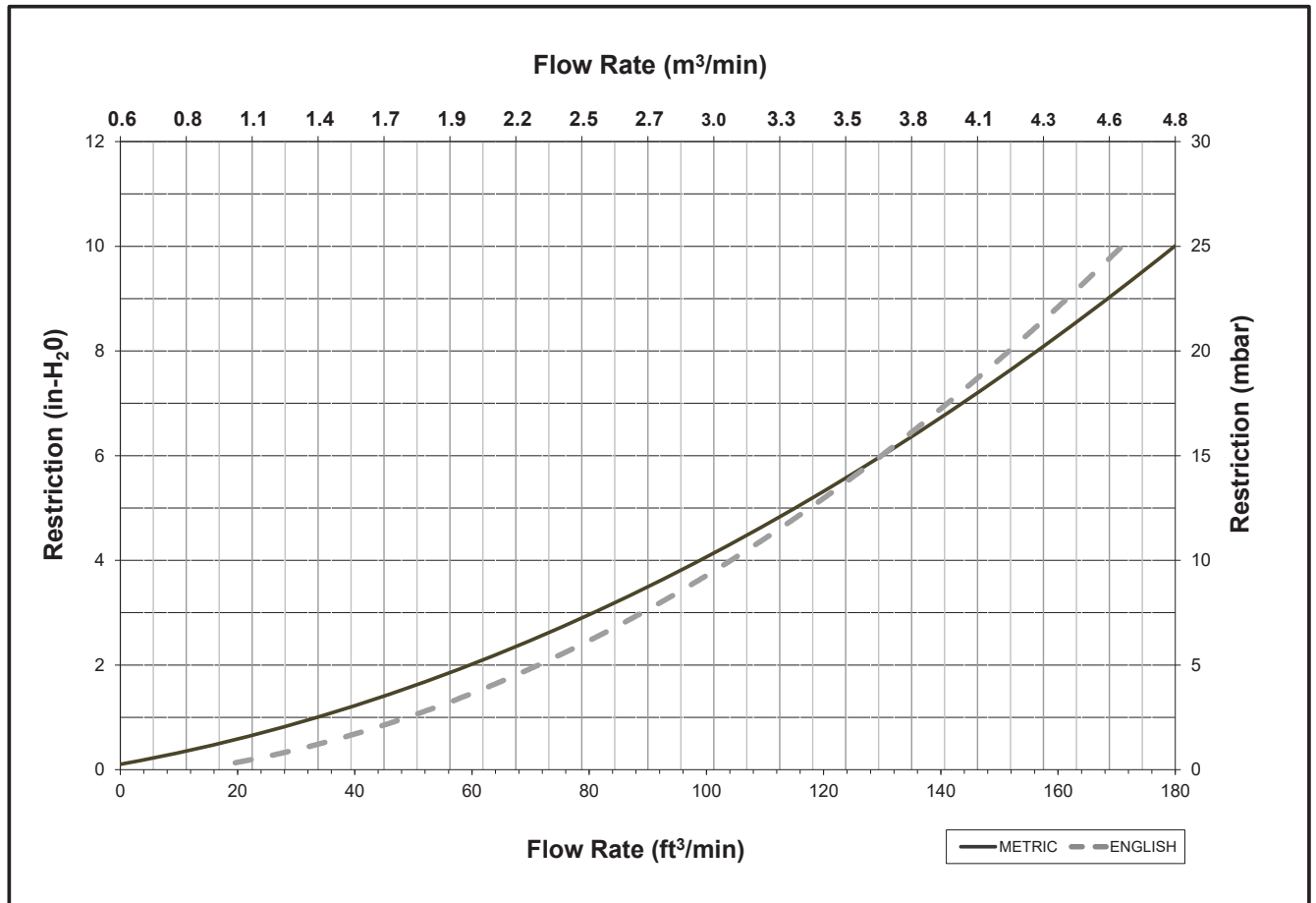

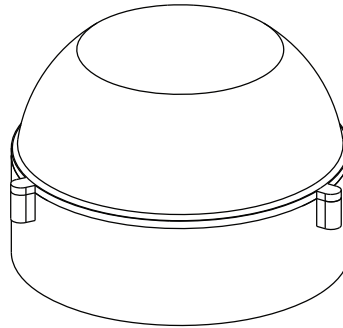

Specifications

Specification	AP8403
Width, Overall	8.2" (Ø209.5 mm)
Height, Overall	6.3" (160.4 mm)
Application Flow Rate	100-275 CFM (2.83-7.79 m³/min)
Outlet tube	4.0" (Ø 103.6 mm I.D.)

Specifications subject to change without notice.

Dimensions

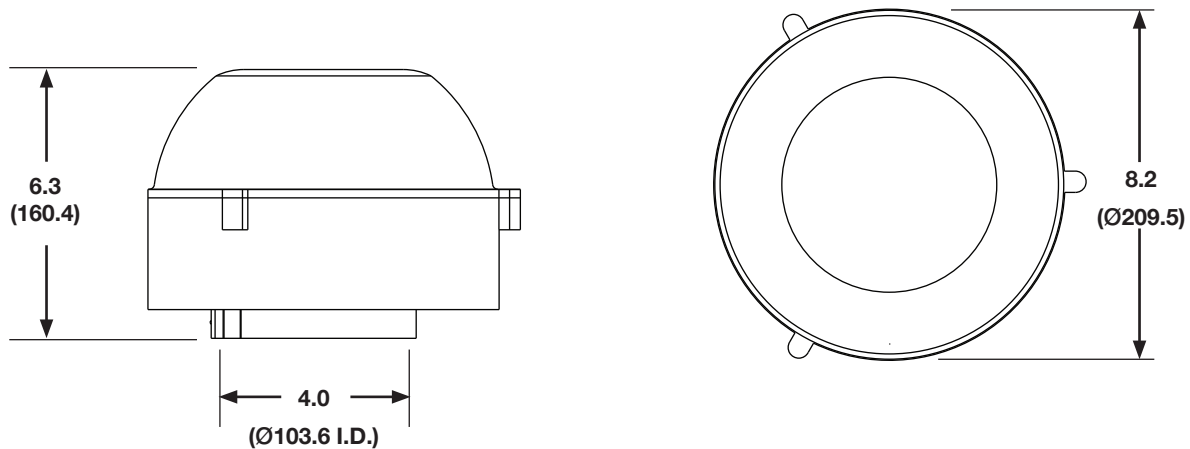

All dimensions are in inches (millimeters).

Ordering Information

Single-Stage Pre-Cleaner	
Part Number	Description
AP8403	Pre-Cleaner

Performance

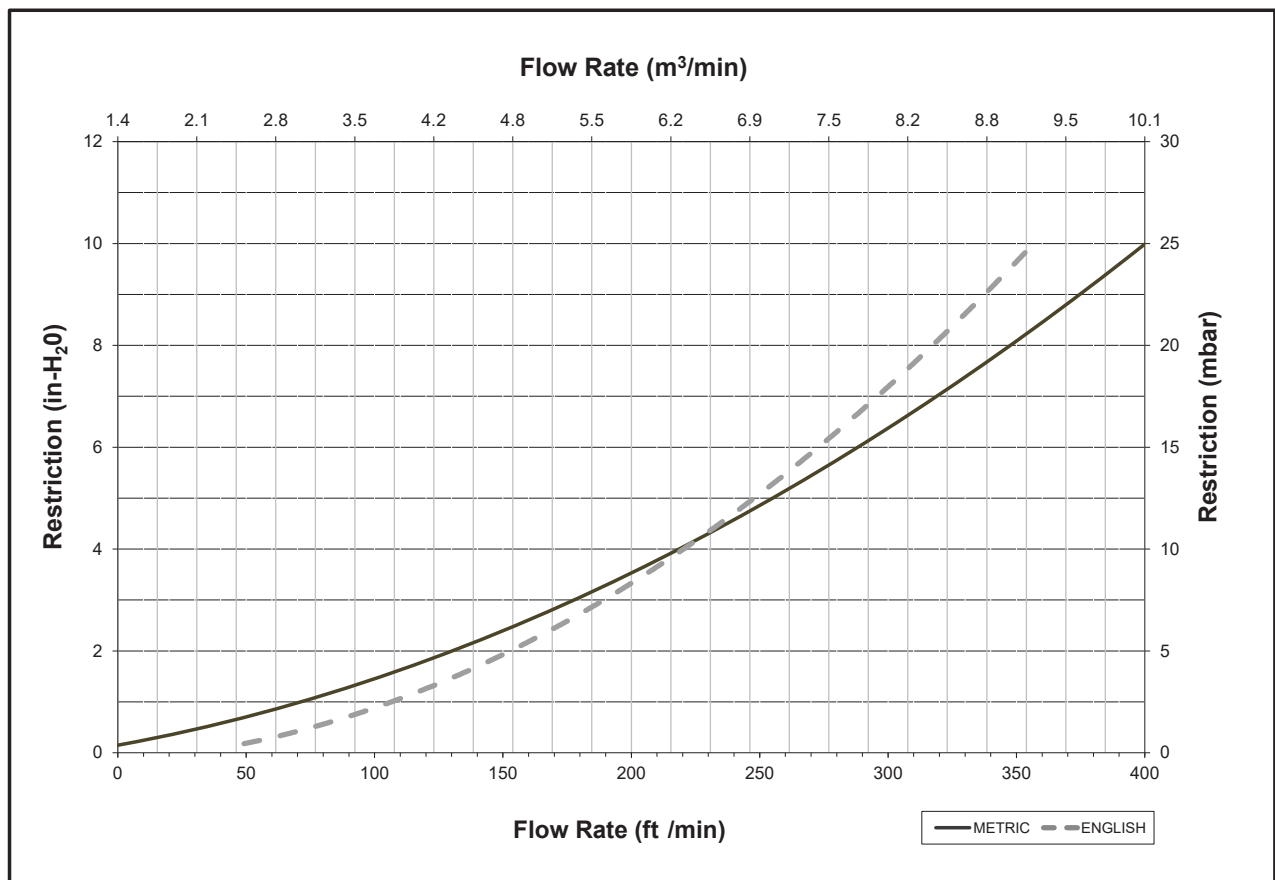

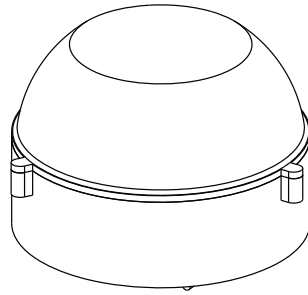

Specifications

Specification	AP8409
Width, Overall	8.2" (Ø209.5 mm)
Height, Overall	6.3" (160.4 mm)
Application Flow Rate	275-350 CFM (7.79-9.91 m³/min)
Outlet tube	4.0" (Ø 103.6 mm I.D.)

Specifications subject to change without notice.

Dimensions

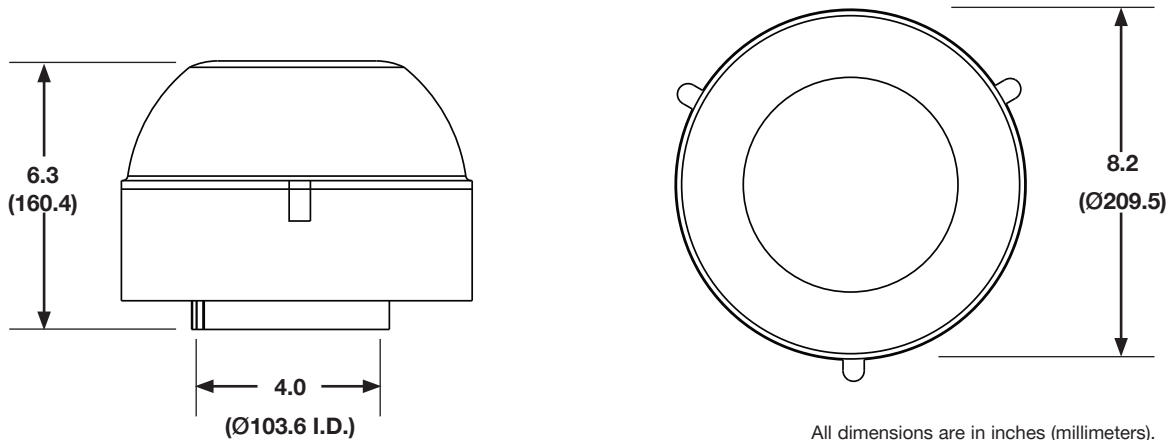

All dimensions are in inches (millimeters).

Ordering Information

Single-Stage Pre-Cleaner	
Part Number	Description
AP8409	Pre-Cleaner

Performance

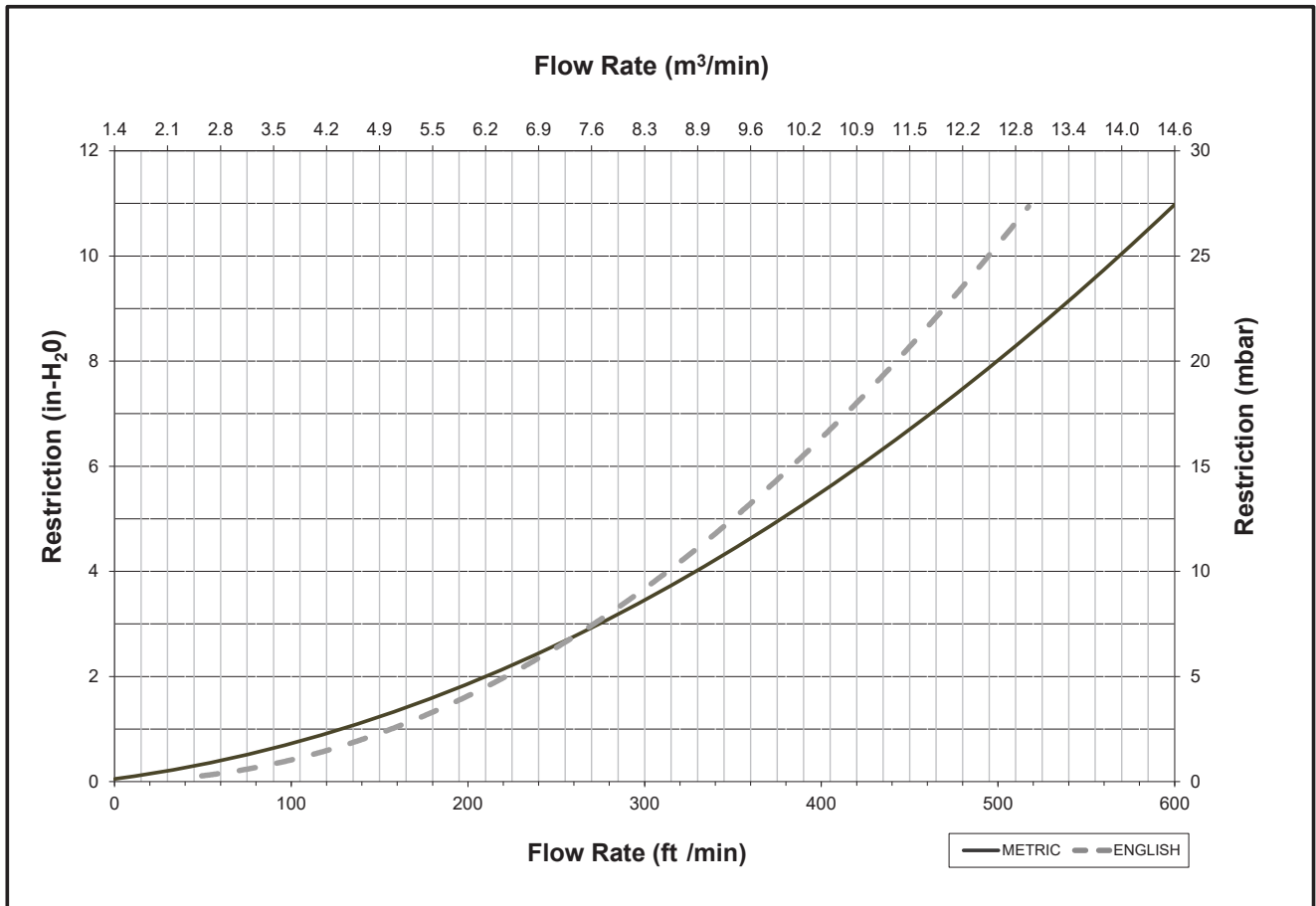

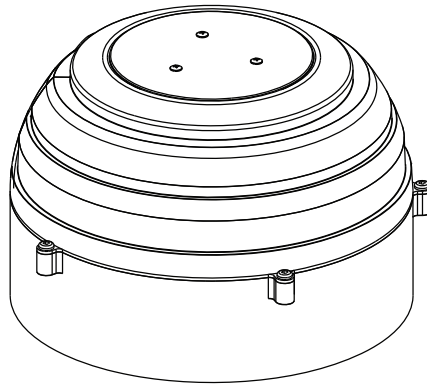

Specifications

Specification	AP8421
Width, Overall	10.6" (Ø270.0 mm)
Height, Overall	8.0" (202.7 mm)
Application Flow Rate	350-500 CFM (9.91-14.16 m ³ /min)
Outlet tube	5.0" (Ø 128.1 mm I.D.)

Specifications subject to change without notice.

Dimensions

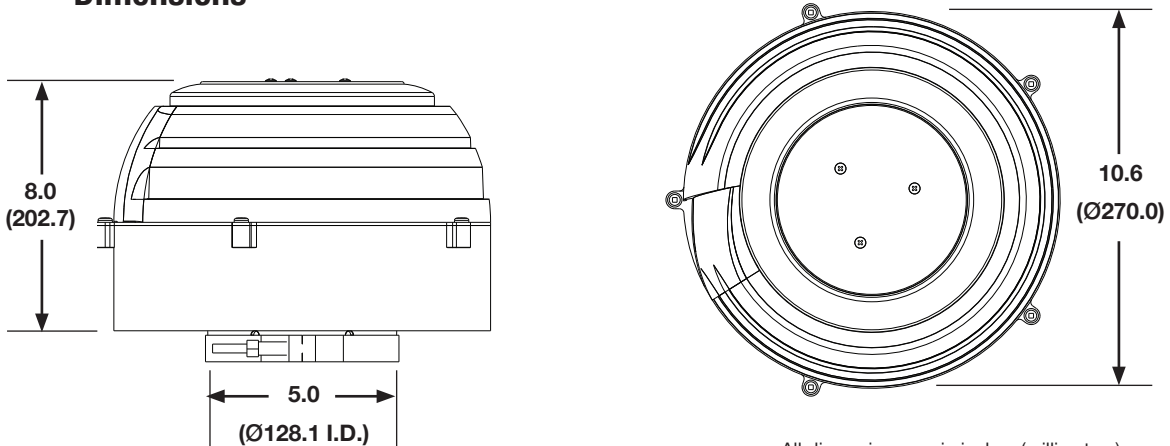

All dimensions are in inches (millimeters).

Ordering Information

Single-Stage Pre-Cleaner	
Part Number	Description
AP8421	Pre-Cleaner

Performance

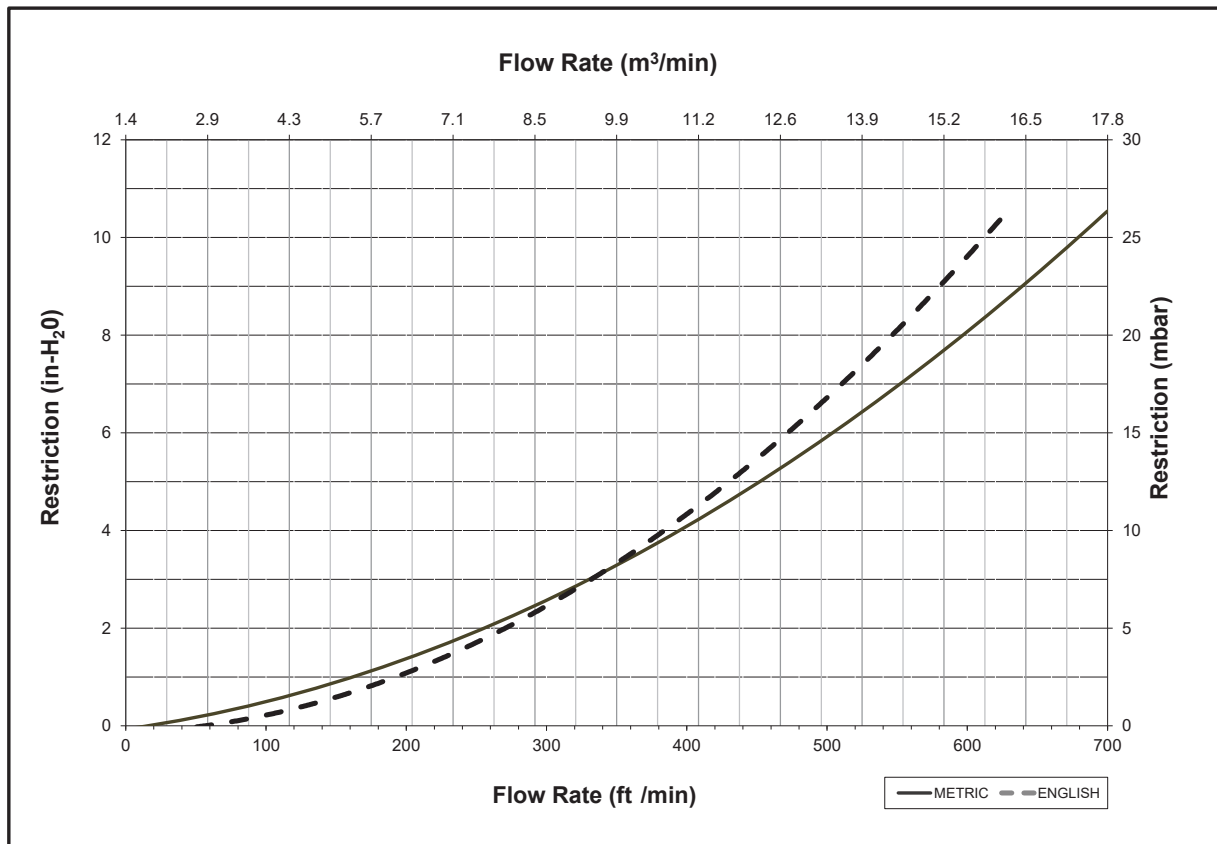

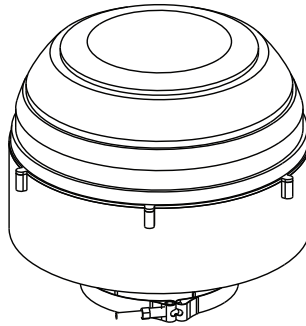

Specifications

Specification	AP8404
Width, Overall	12.4" (Ø314.4 mm)
Height, Overall	11.0" (280.5 mm)
Application Flow Rate	500-650 CFM (14.16-18.41 m³/min)
Outlet tube	6.0" (Ø 153.4 mm I.D.)

Specifications subject to change without notice.

Dimensions

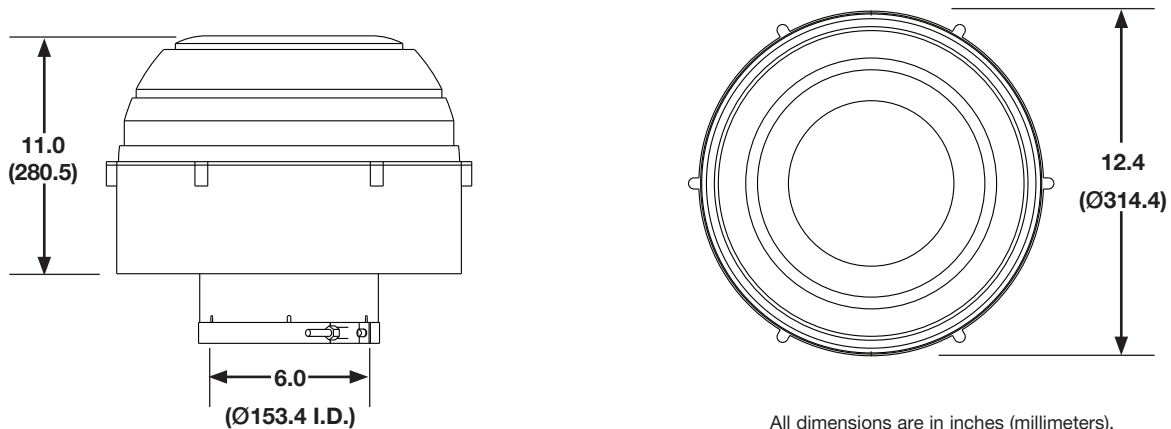

All dimensions are in inches (millimeters).

Ordering Information

Single-Stage Pre-Cleaner	
Part Number	Description
AP8404	Pre-Cleaner

Performance

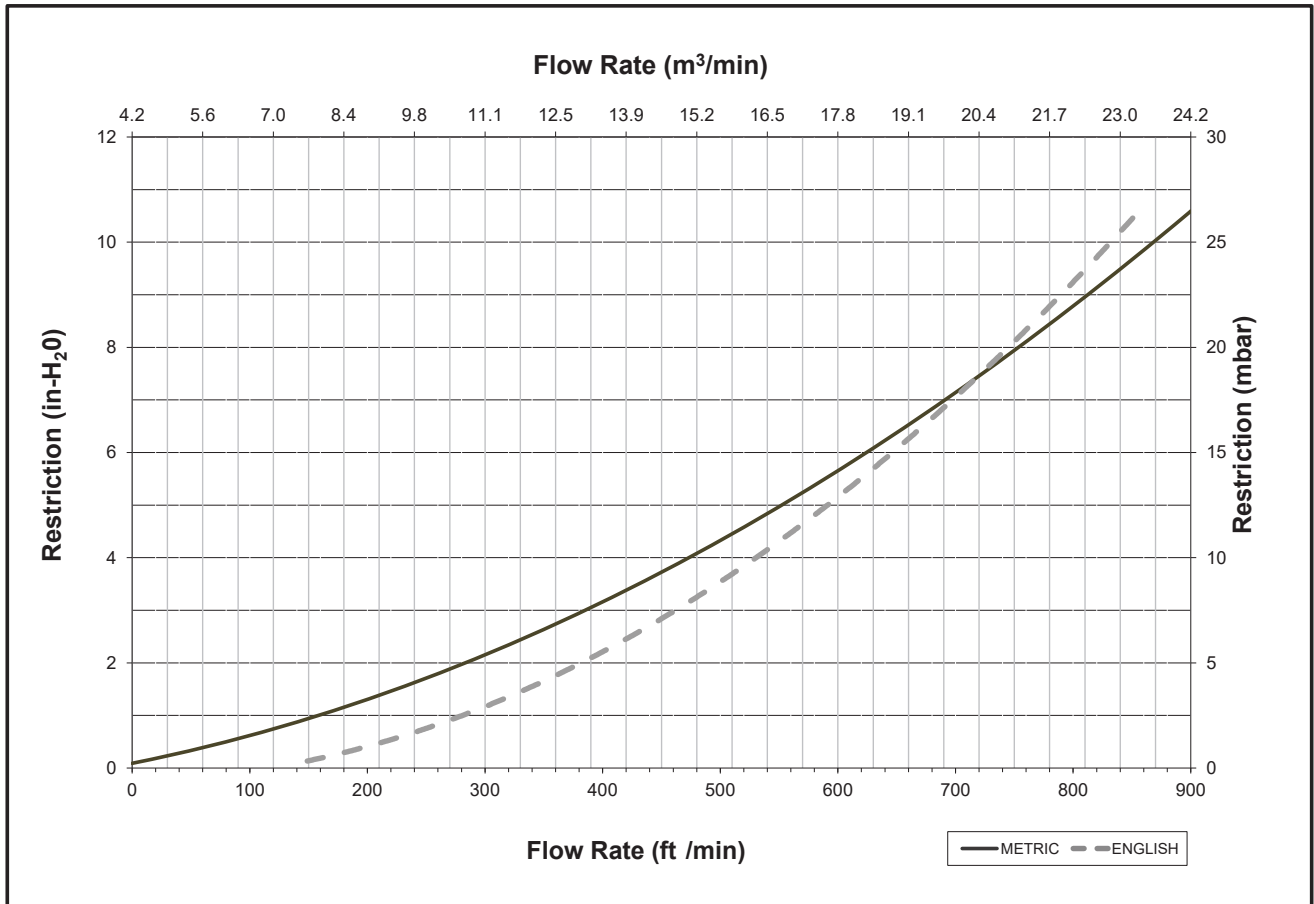

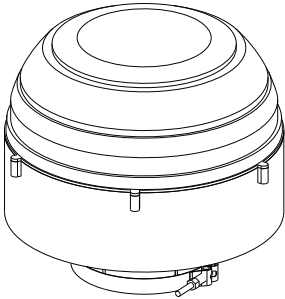

Specifications

Specification	AP8410
Width, Overall	12.4" (Ø314.4 mm)
Height, Overall	11.0" (280.5 mm)
Application Flow Rate	650-800 CFM (18.41-22.65 m³/min)
Outlet tube	6.0" (Ø 153.4 mm I.D.)

Specifications subject to change without notice.

Dimensions

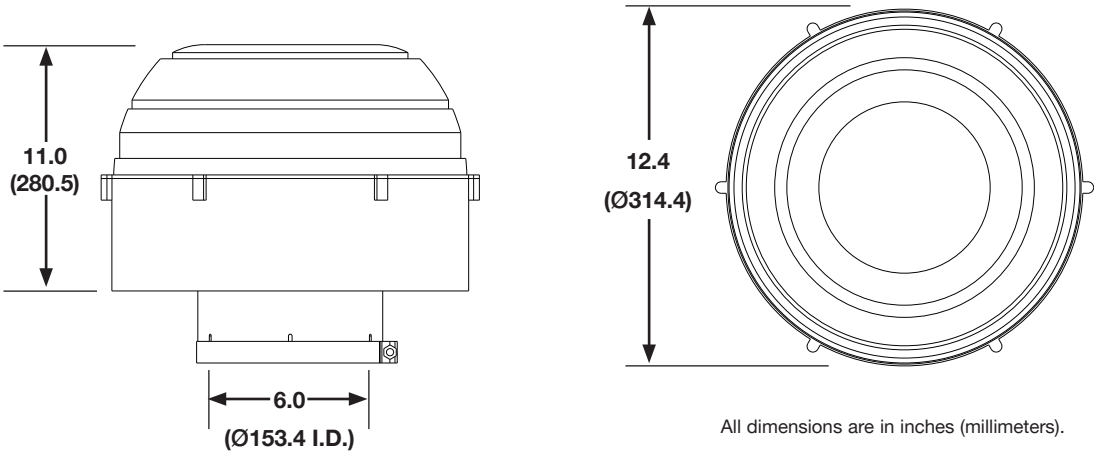

Ordering Information

Single-Stage Pre-Cleaner	
Part Number	Description
AP8410	Pre-Cleaner

Performance

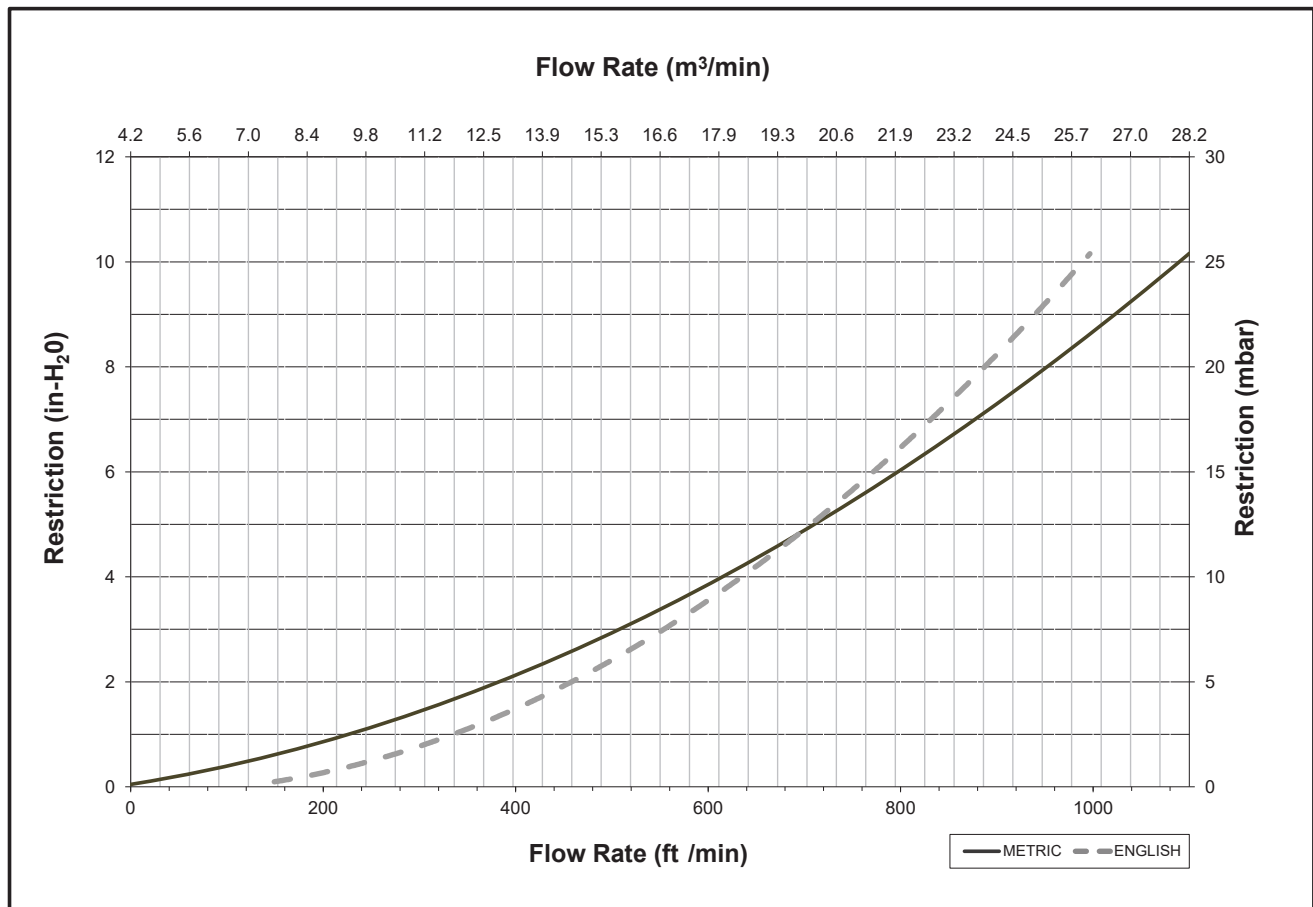

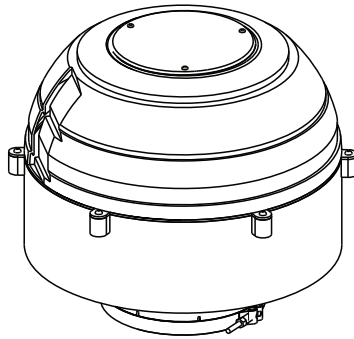

Specifications

Specification	AP8405
Width, Overall	16.4" (Ø416.4 mm)
Height, Overall	14.9" (377.5 mm)
Application Flow Rate	800-1150 CFM (22.65-32.56 m ³ /min)
Outlet tube	8.0" (Ø 204.7 mm I.D.)

Specifications subject to change without notice.

Dimensions

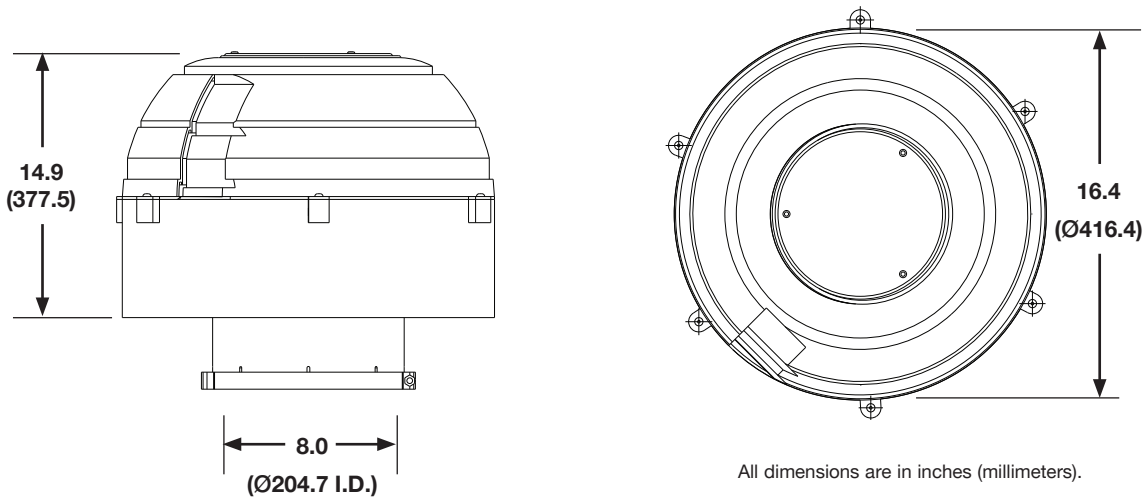

Ordering Information

Single-Stage Pre-Cleaner	
Part Number	Description
AP8405	Pre-Cleaner

Performance

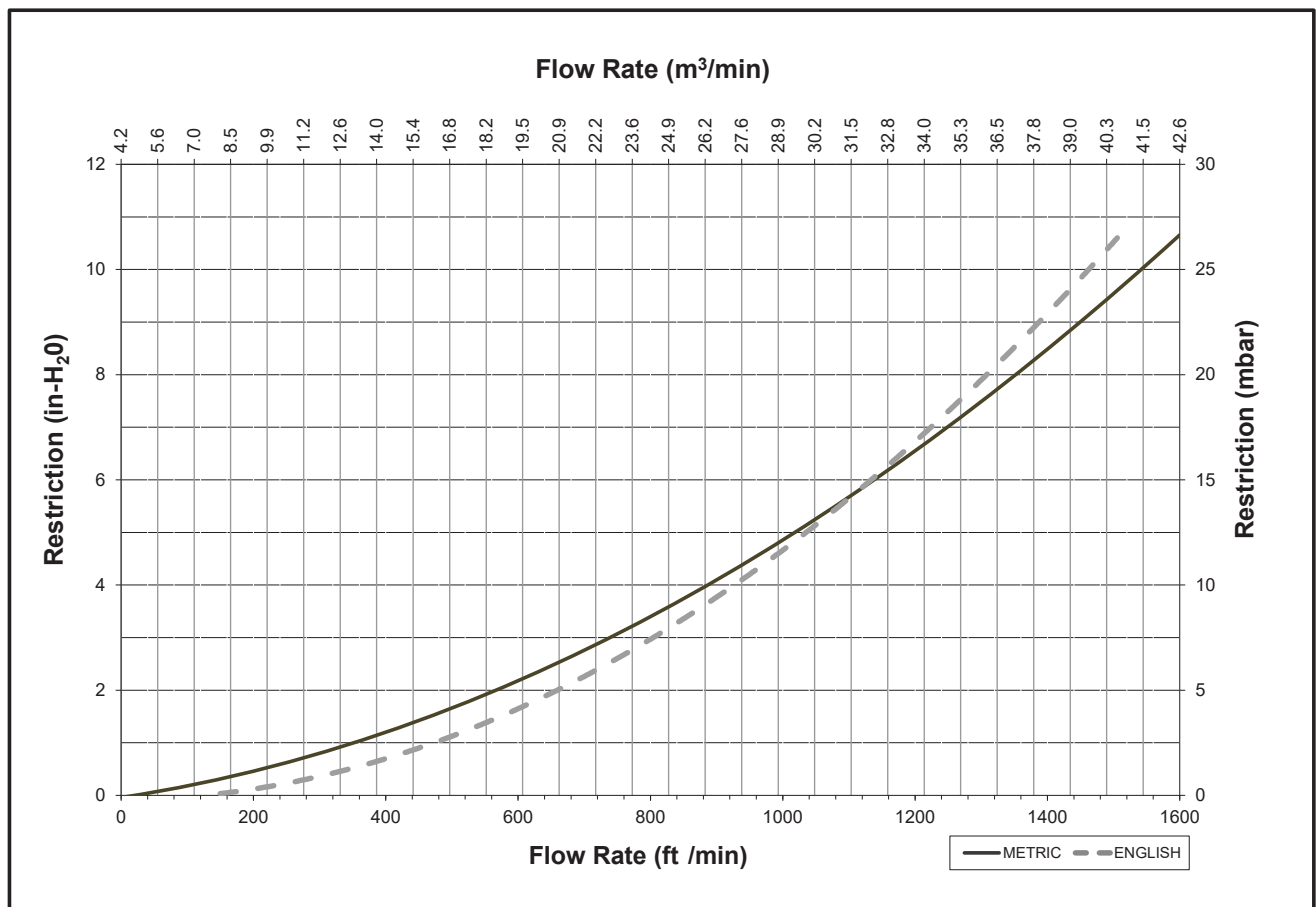

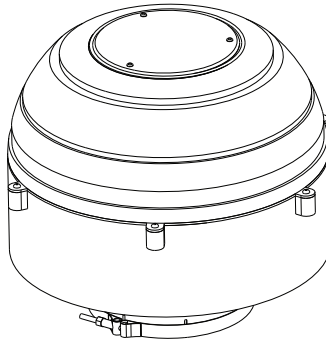

Specifications

Specification	AP8406
Width, Overall	16.4" (Ø416.4 mm)
Height, Overall	14.9" (377.5 mm)
Application Flow Rate	1150-1400 CFM (32.56-39.64 m³/min)
Outlet tube	8.0" (Ø 204.7 mm I.D.)

Specifications subject to change without notice.

Dimensions

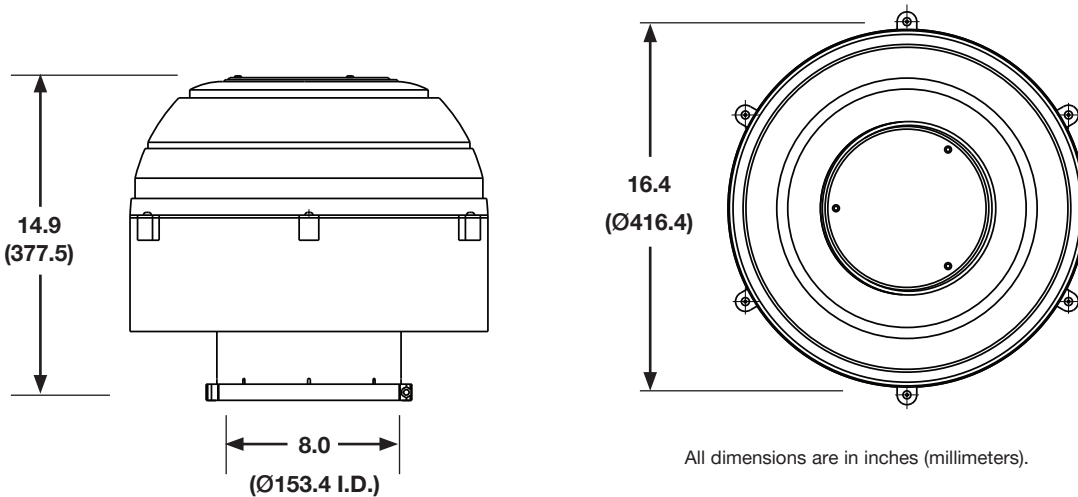

All dimensions are in inches (millimeters).

Ordering Information

Single-Stage Pre-Cleaner	
Part Number	Description
AP8406	Pre-Cleaner

Performance

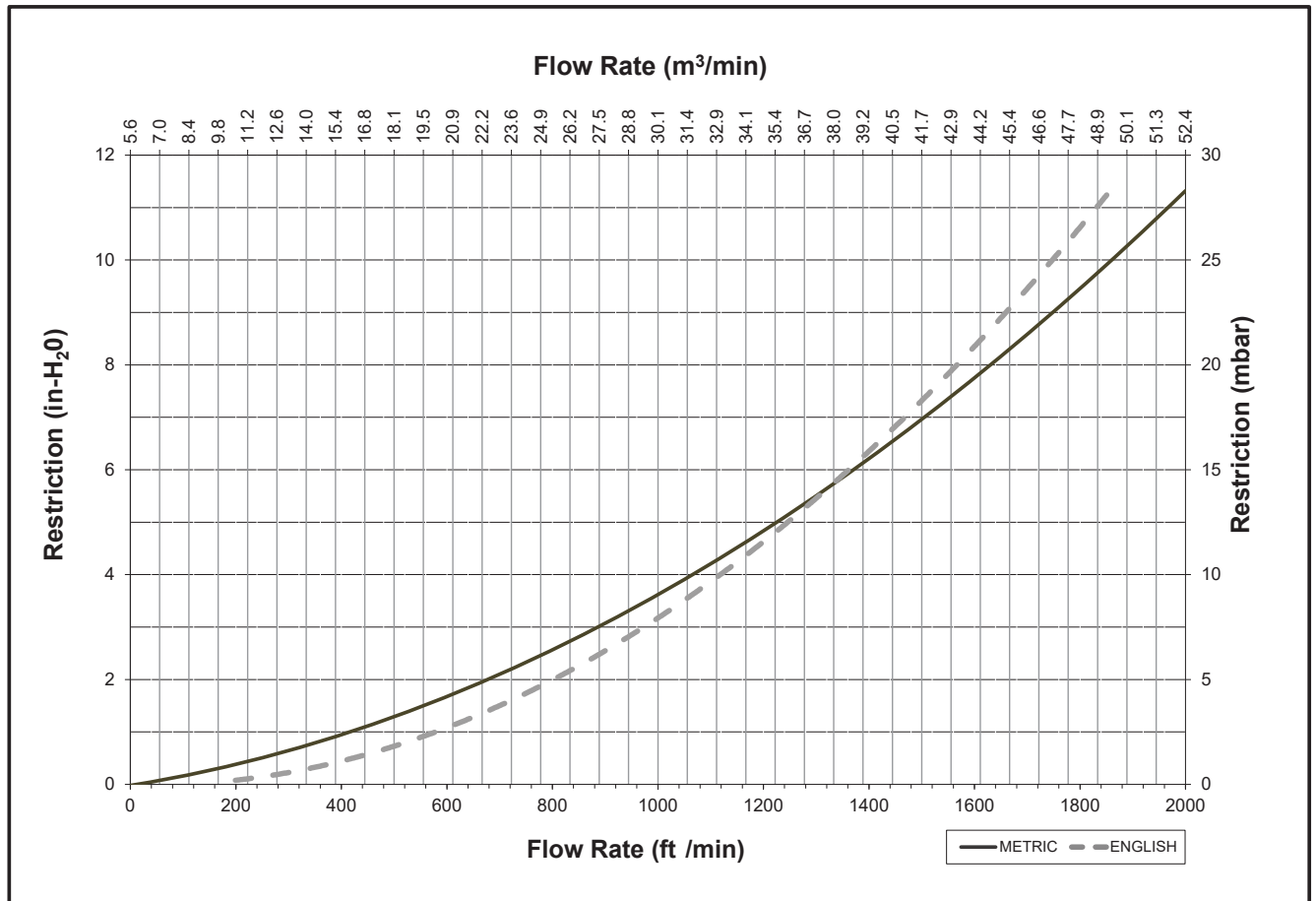

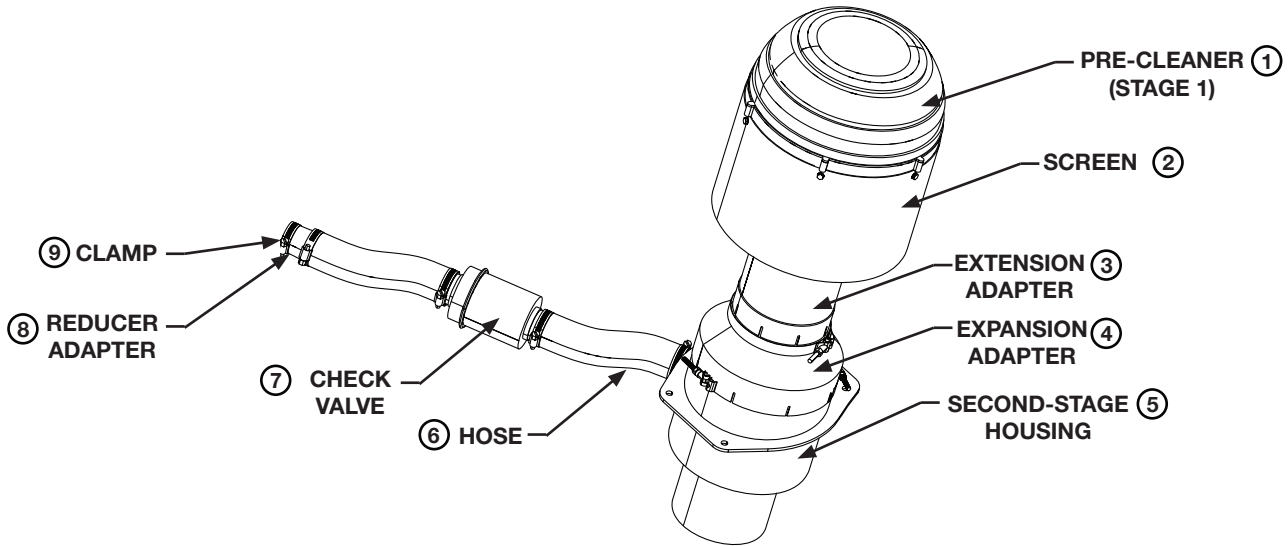

Specifications

Specification	AP85041
Width, Overall	12.5" (Ø 317.5 mm)
Height, Overall	36.8" (935.1 mm)
Application Flow Rate	500-650 CFM (14.16 - 18.41 m ³ /min)
Outlet Tube	6.0" (Ø 152.4 mm)

Specifications subject to change without notice.

Dimensions

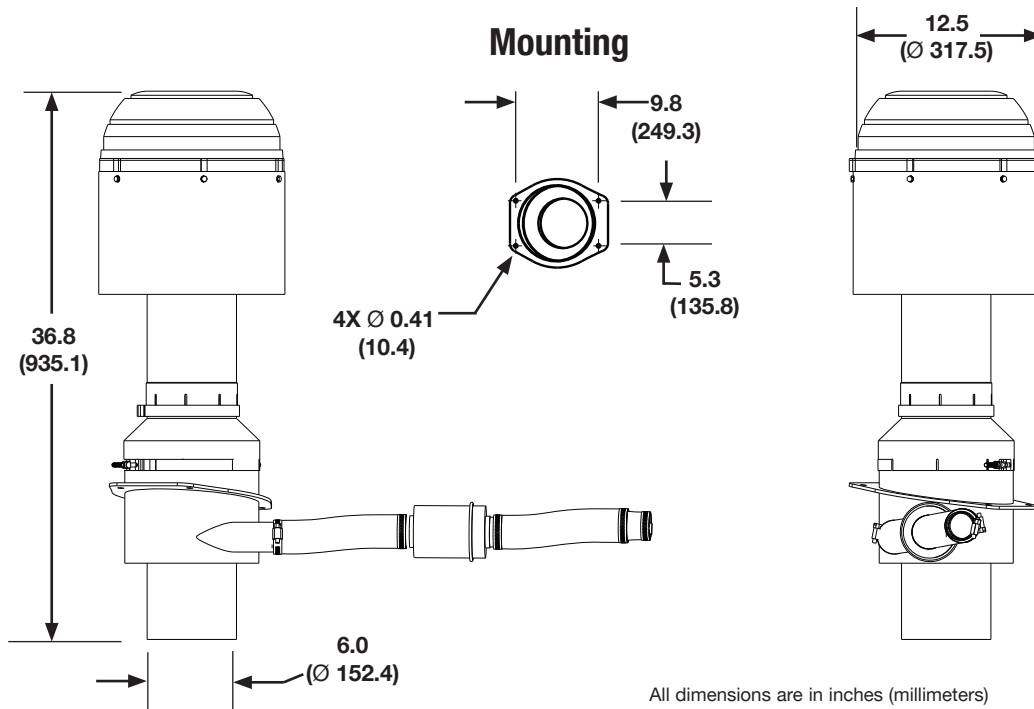

All dimensions are in inches (millimeters)

Ordering Information

Dual-Stage Pre-Cleaner	
Part Number	Description
AP85041	Pre-Cleaner

Service Parts		
	Part Number	Description
①	AP08404	Pre-Cleaner
②	3946090S	Screen
③	3939411S	6" Extension Adapter
④	3939412S	6" to 9" Expansion Adapter
⑤	3953520S	Second-Stage Housing
⑥	3952359S	Hose
⑦	3953535S	Check Valve
⑧	3952334S	Reducer Adapter
⑨	3952353S	Clamp

Performance

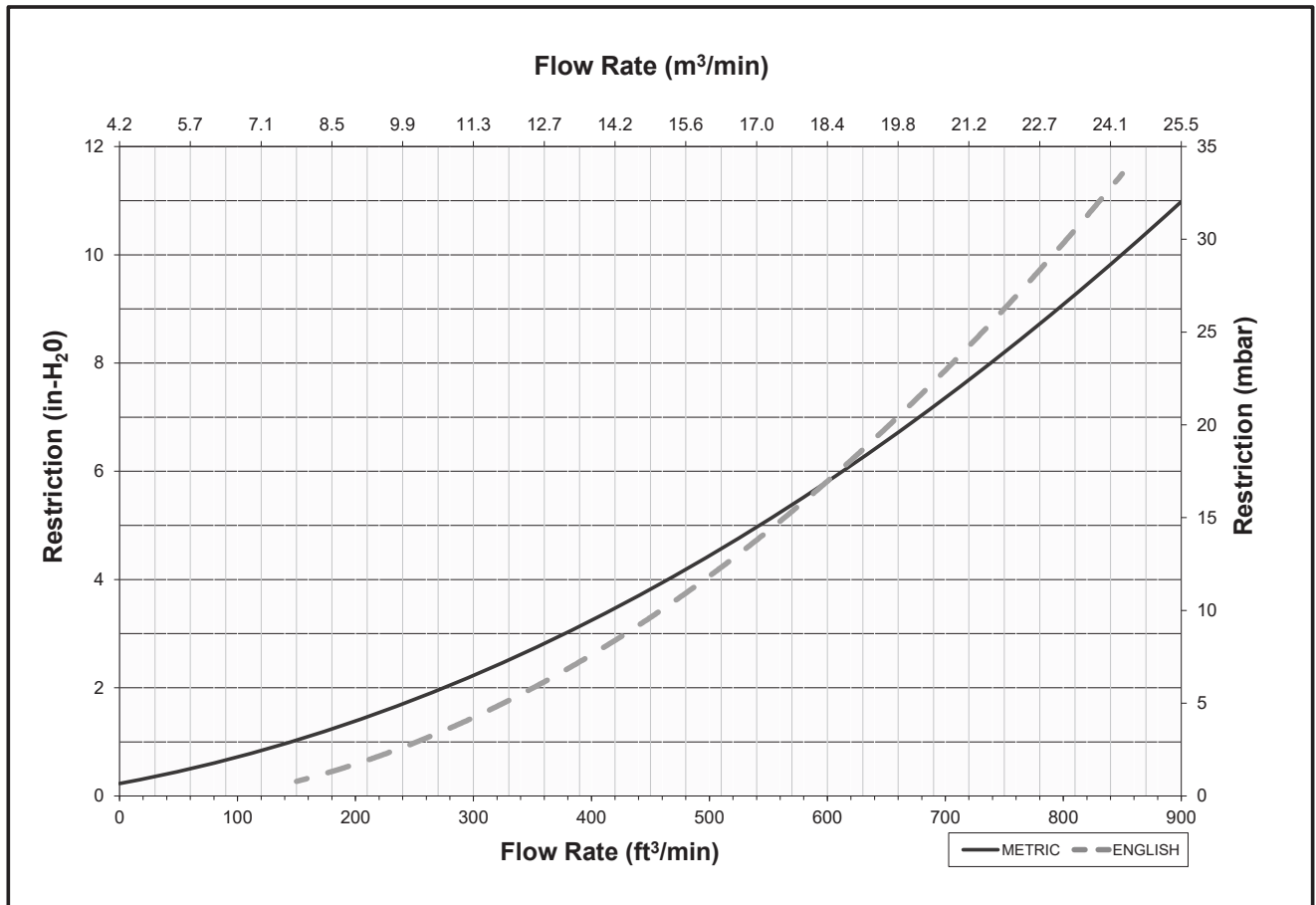

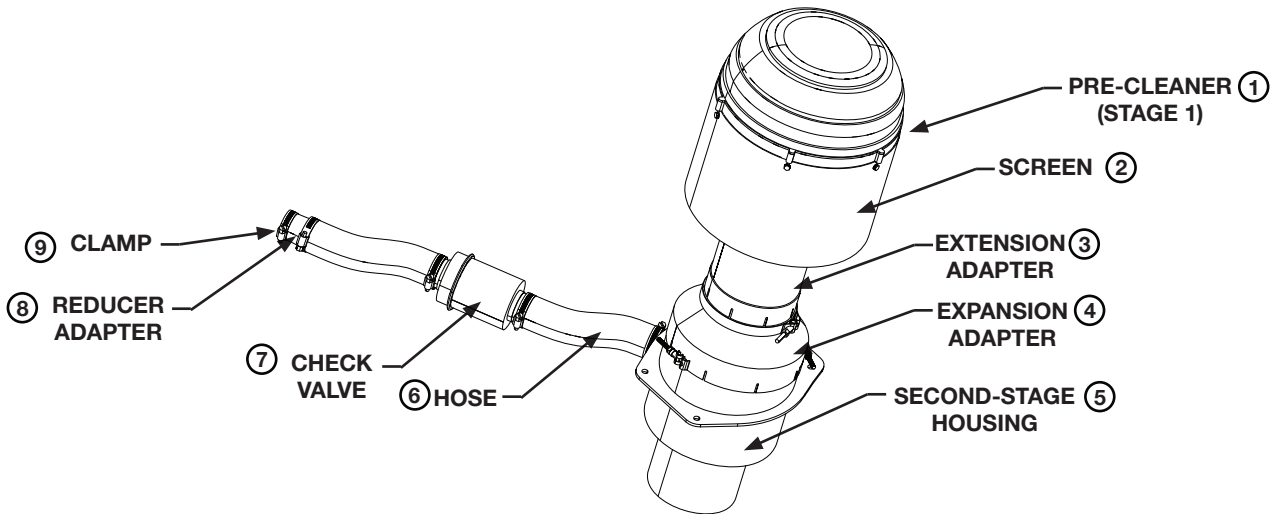

Specifications

Specification	AP85042
Width, Overall	12.5" (Ø 317.5 mm)
Height, Overall	34.7" (881.0 mm)
Application Flow Rate	500-650 CFM (14.16 -18.41 m ³ /min)
Outlet Tube	6.0" (Ø 152.4 mm)

Specifications subject to change without notice.

Dimensions

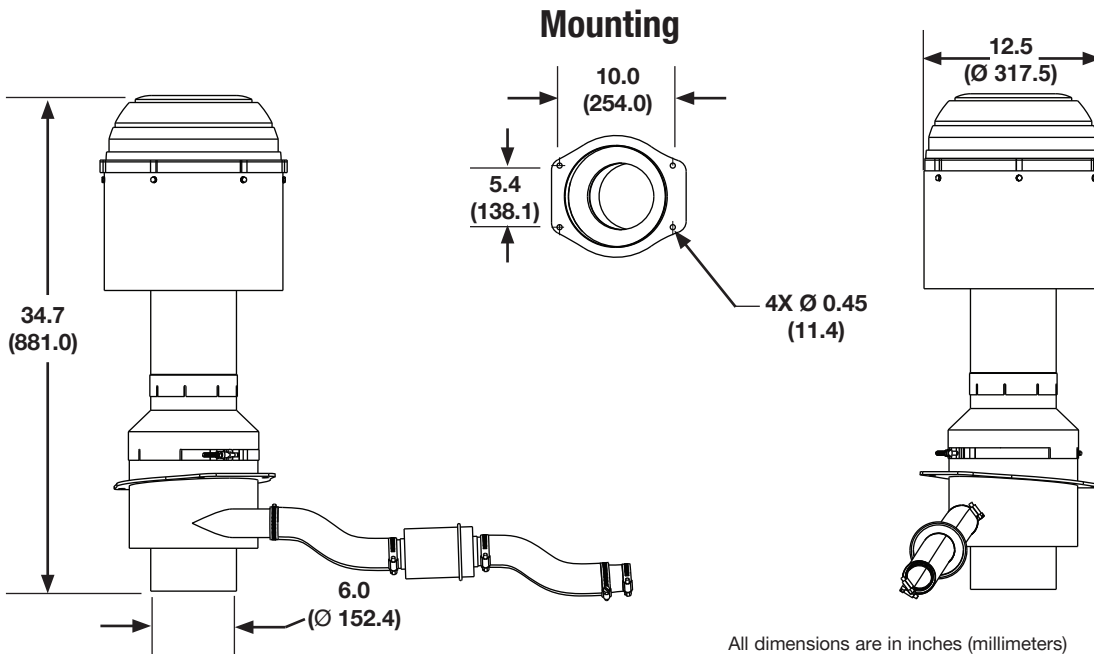

All dimensions are in inches (millimeters)

Ordering Information

Dual-Stage Pre-Cleaner	
Part Number	Description
AP85042	Dual-Stage Pre-Cleaner

Service Parts		
	Part Number	Description
①	AP08404	Pre-Cleaner
②	3946090S	Screen
③	3939411S	6" Extension Adapter
④	3939412S	6" to 9" Expansion Adapter
⑤	3953521S	Second-Stage Housing
⑥	3952359S	Hose
⑦	3953535S	Check Valve
⑧	3952334S	Reducer Adapter
⑨	3952353S	Clamp

Performance

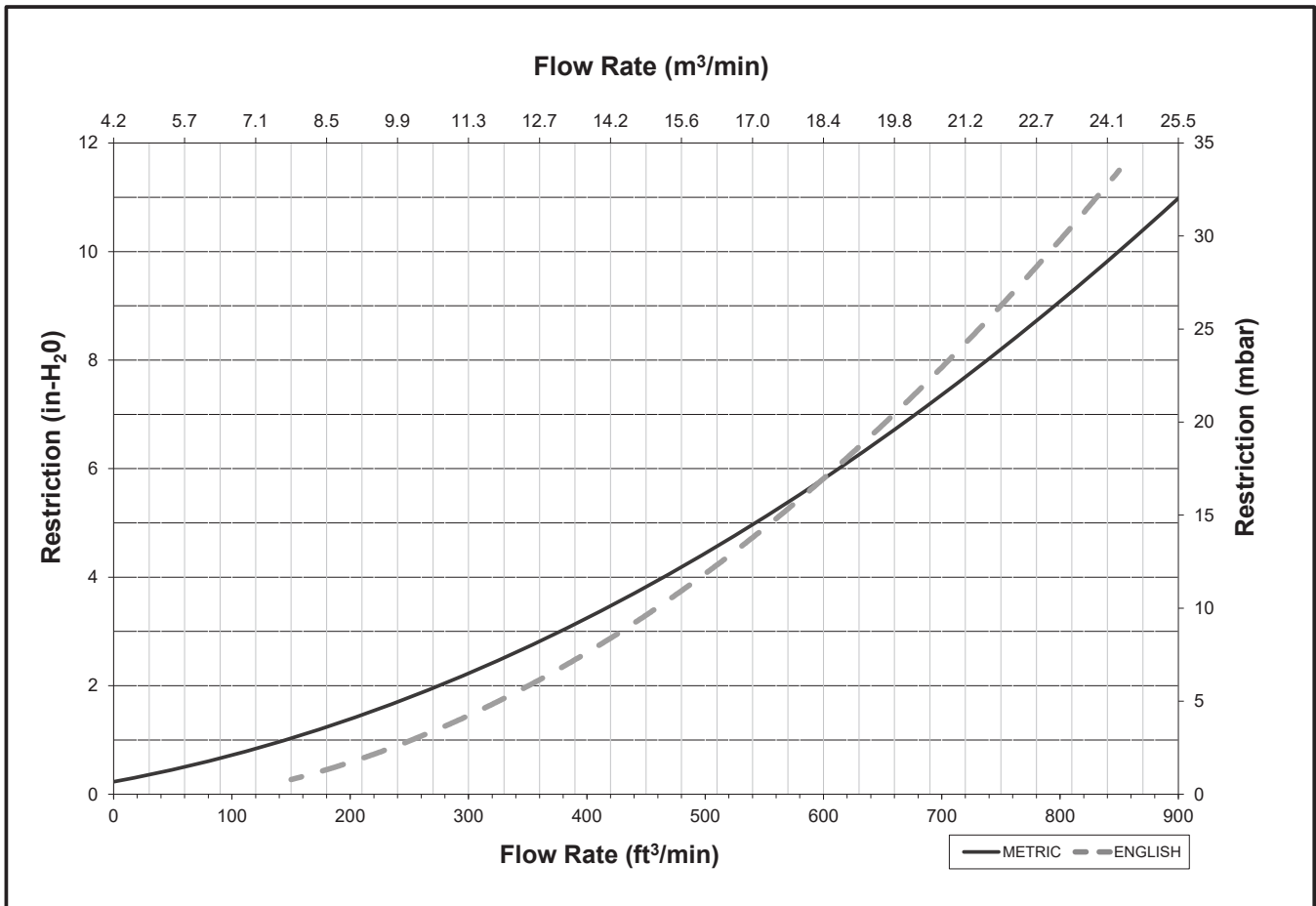

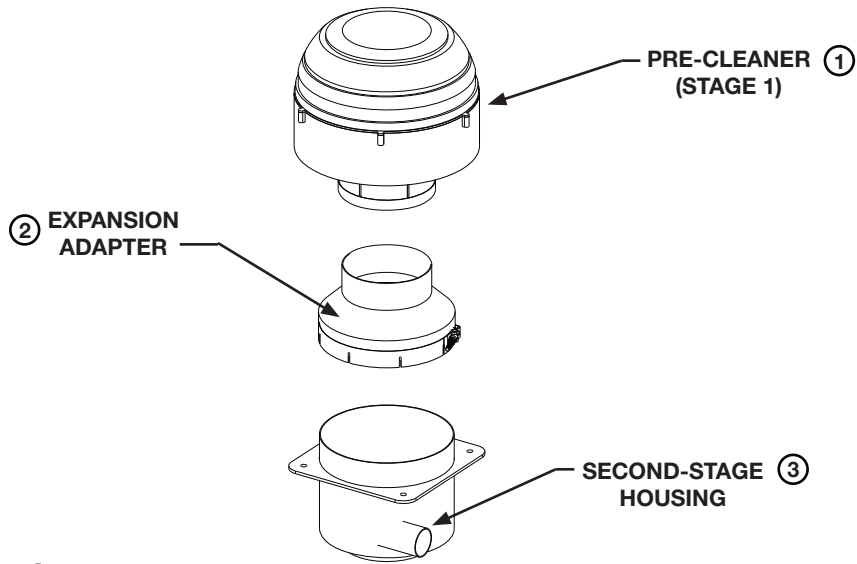

Specifications

Specification	AP85043
Width, Overall	12.5" (Ø 317.5 mm)
Height, Overall	21.5" (545.4 mm)
Application Flow Rate	500-650 CFM (14.16 -18.41 m ³ /min)
Outlet Tube	6.0" (Ø 152.4 mm)

Specifications subject to change without notice.

Dimensions

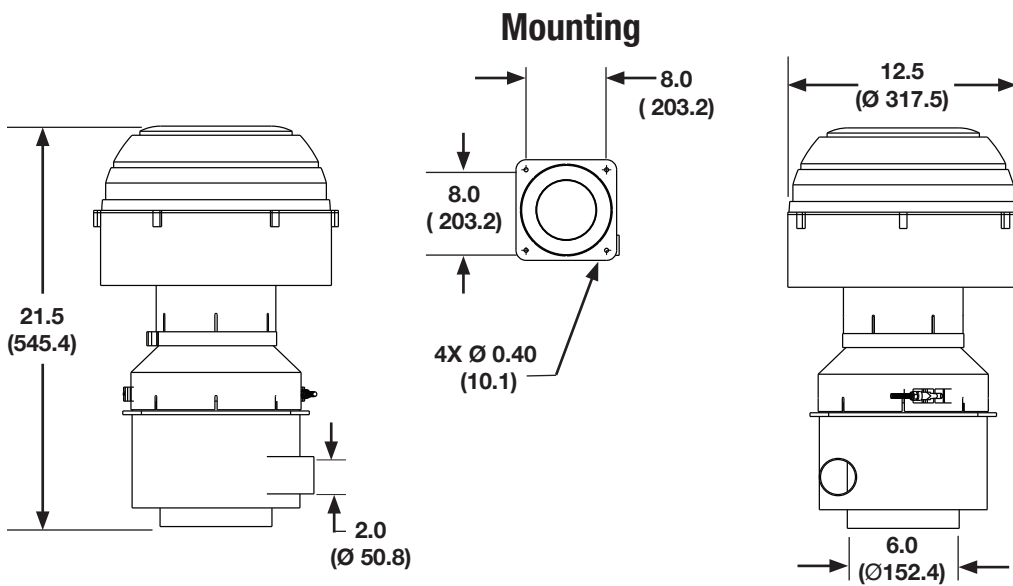

All dimensions are in inches (millimeters)

Ordering Information

Dual-Stage Pre-Cleaner	
Part Number	Description
AP85043	Dual-Stage Pre-Cleaner

Service Parts	
Part Number	Description
① AP8404	Pre-Cleaner
② 3939412S	6" to 9" Expansion Adapter
③ 3953525S	Second-Stage Housing

Performance

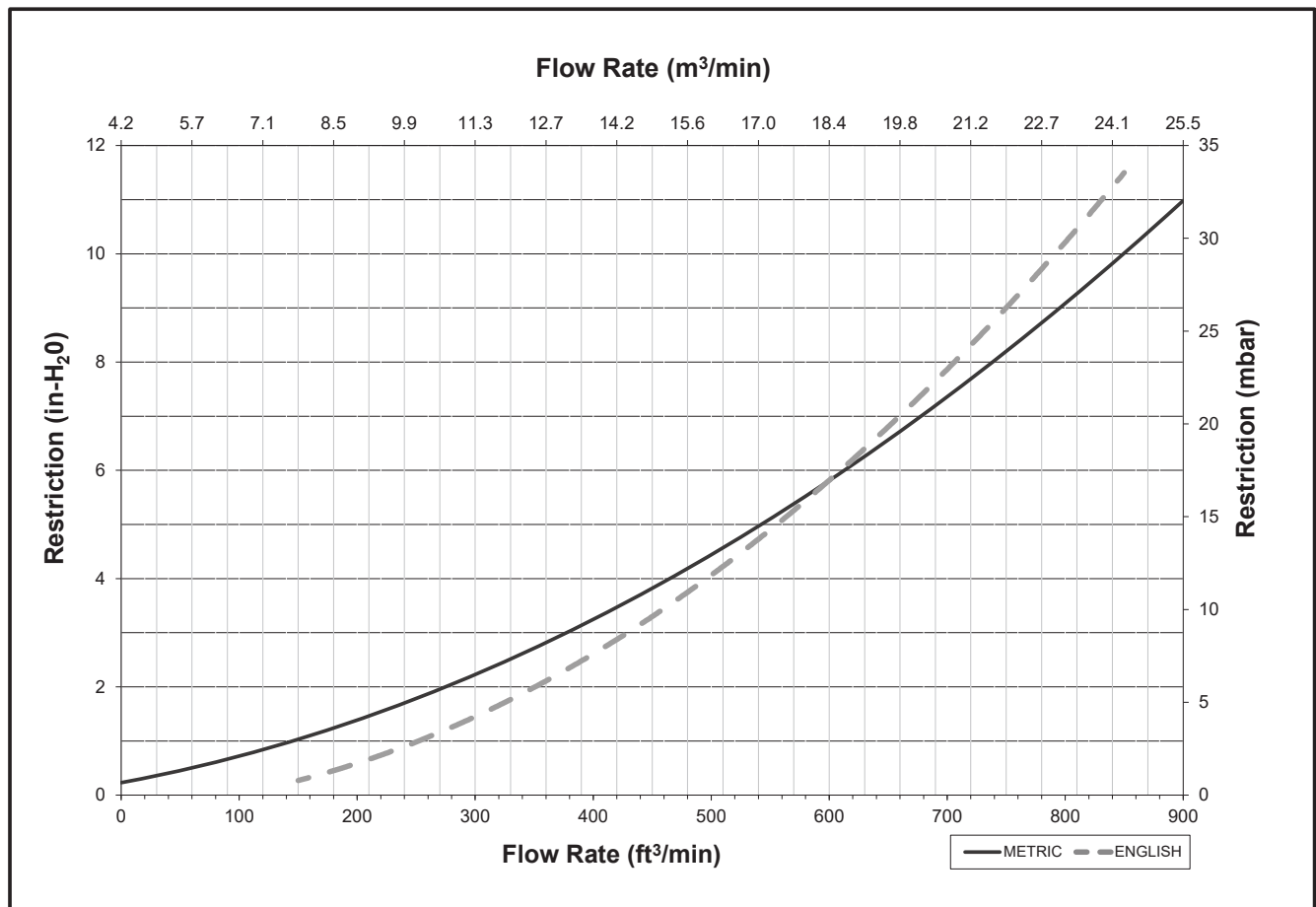

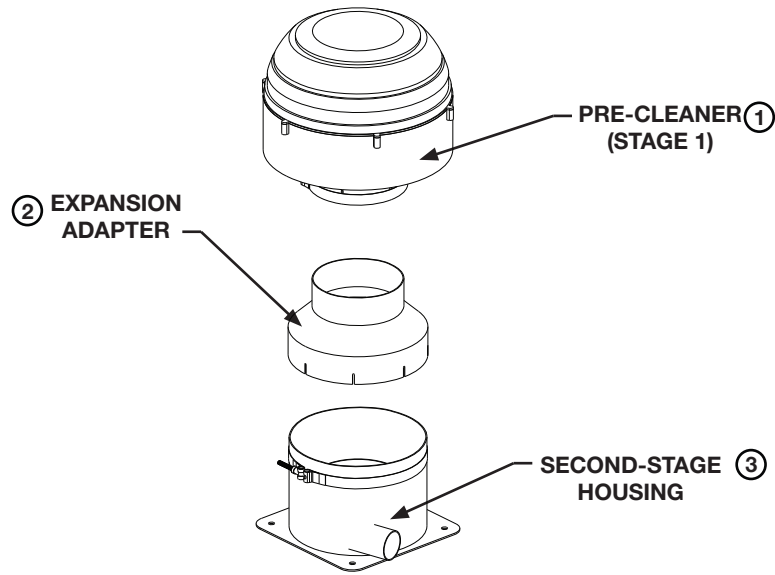

Specifications

Specification	AP85044
Width, Overall	12.5" (Ø 317.5 mm)
Height, Overall	20.9" (531.5 mm)
Application Flow Rate	500-650 CFM (14.16 -18.41 m ³ /min)
Outlet Tube	6.0" (Ø 152.4 mm)

Specifications subject to change without notice.

Dimensions

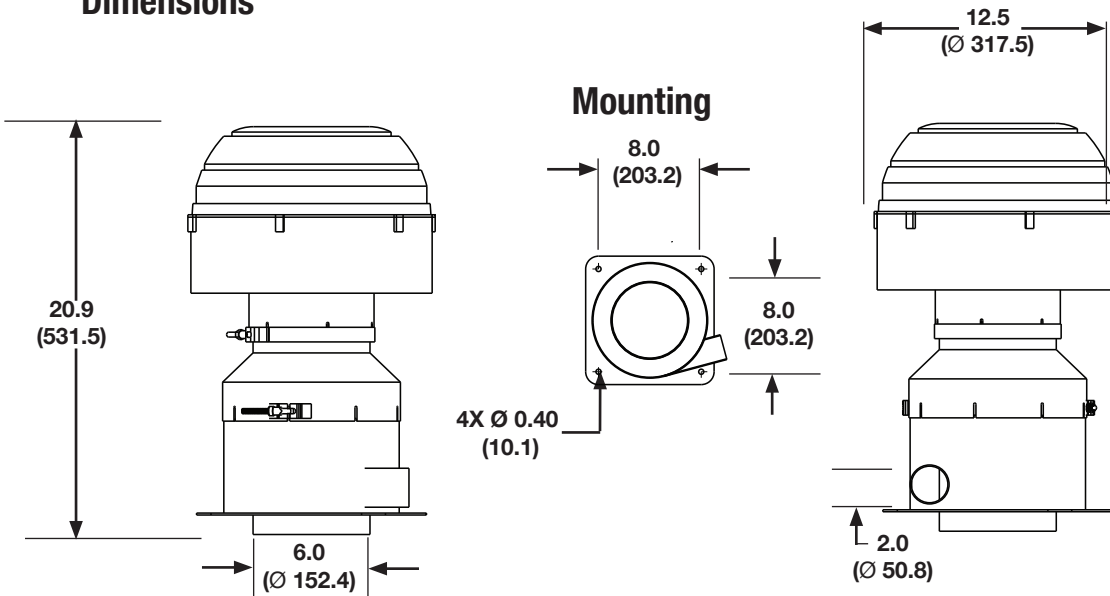

All dimensions are in inches (millimeters)

Ordering Information

Dual-Stage Pre-Cleaner	
Part Number	Description
AP85044	Dual-Stage Pre-Cleaner

Service Parts		
	Part Number	Description
①	AP08404	Pre-Cleaner
②	3939412S	6" to 9" Expansion Adapter
③	3953526S	Second-Stage Housing

Performance

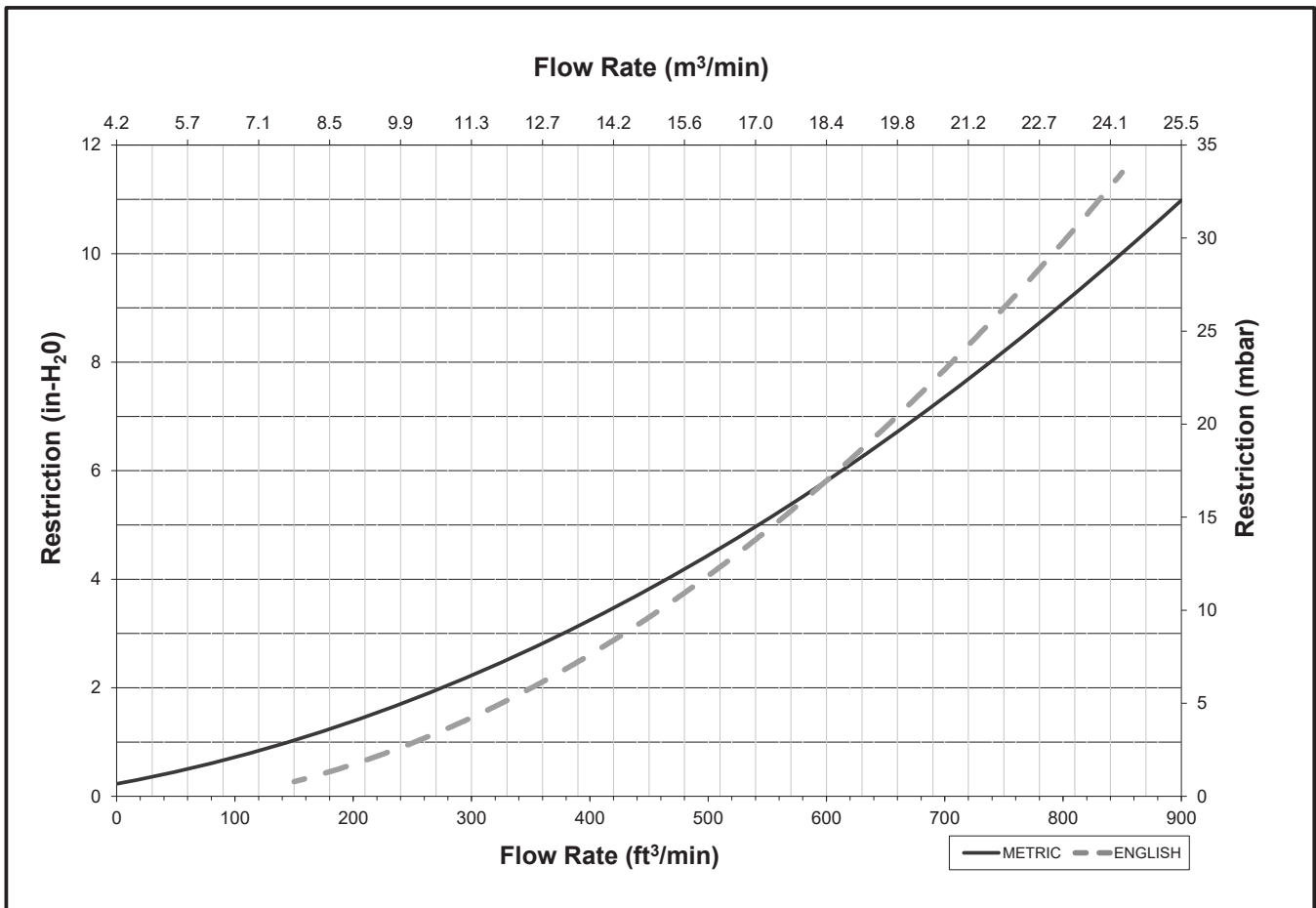

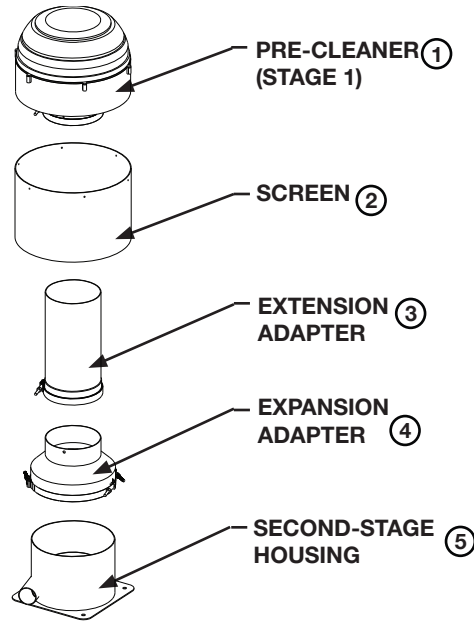

Specifications

Specification	AP85046
Width, Overall	12.5" (Ø 317.5 mm)
Height, Overall	30.8" (783.1 mm)
Application Flow Rate	500-650 CFM (14.16 -18.41 m ³ /min)
Outlet Tube	6.0" (Ø 152.4 mm)

Specifications subject to change without notice.

Dimensions

Mounting

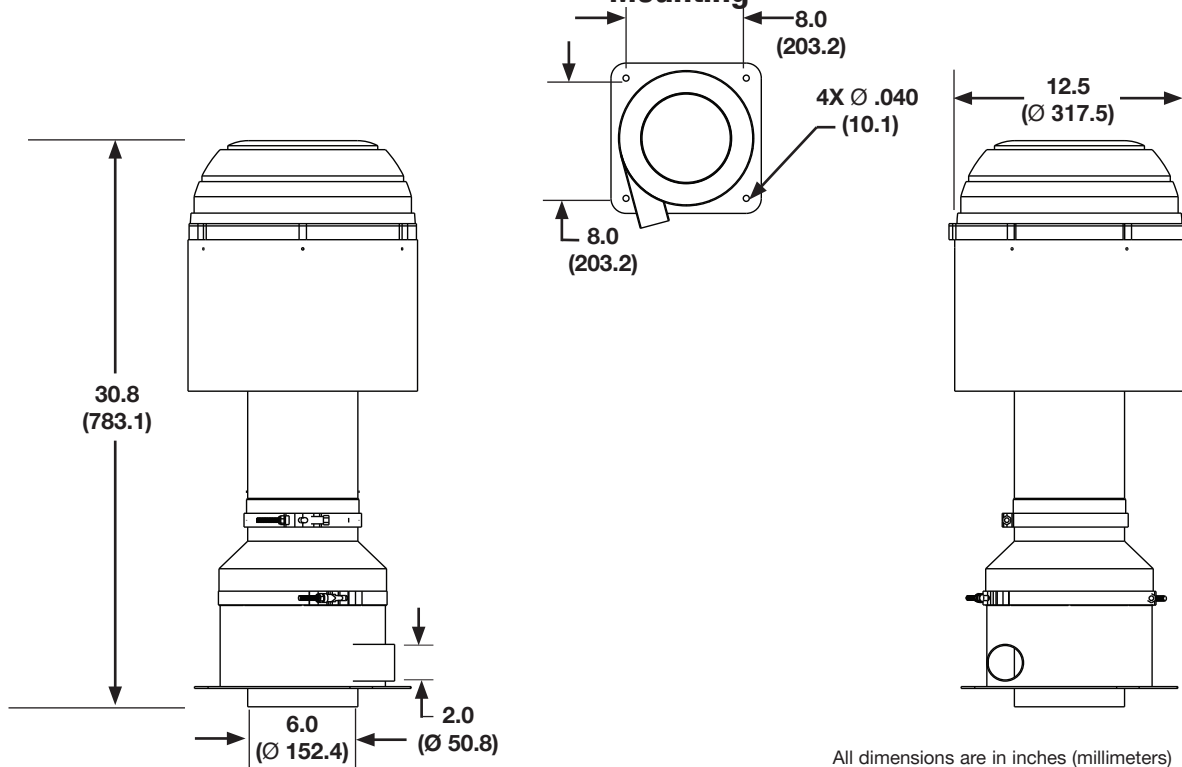

All dimensions are in inches (millimeters)

Ordering Information

Dual-Stage Pre-Cleaner	
Part Number	Description
AP85046	Dual-Stage Pre-Cleaner

Service Parts		
	Part Number	Description
①	AP08404	Pre-Cleaner
②	3946090S	Screen
③	3939411S	6" Extension Adapter
④	3939412S	6" to 9" Expansion Adapter
⑤	3953520S	Second-Stage Housing

Performance

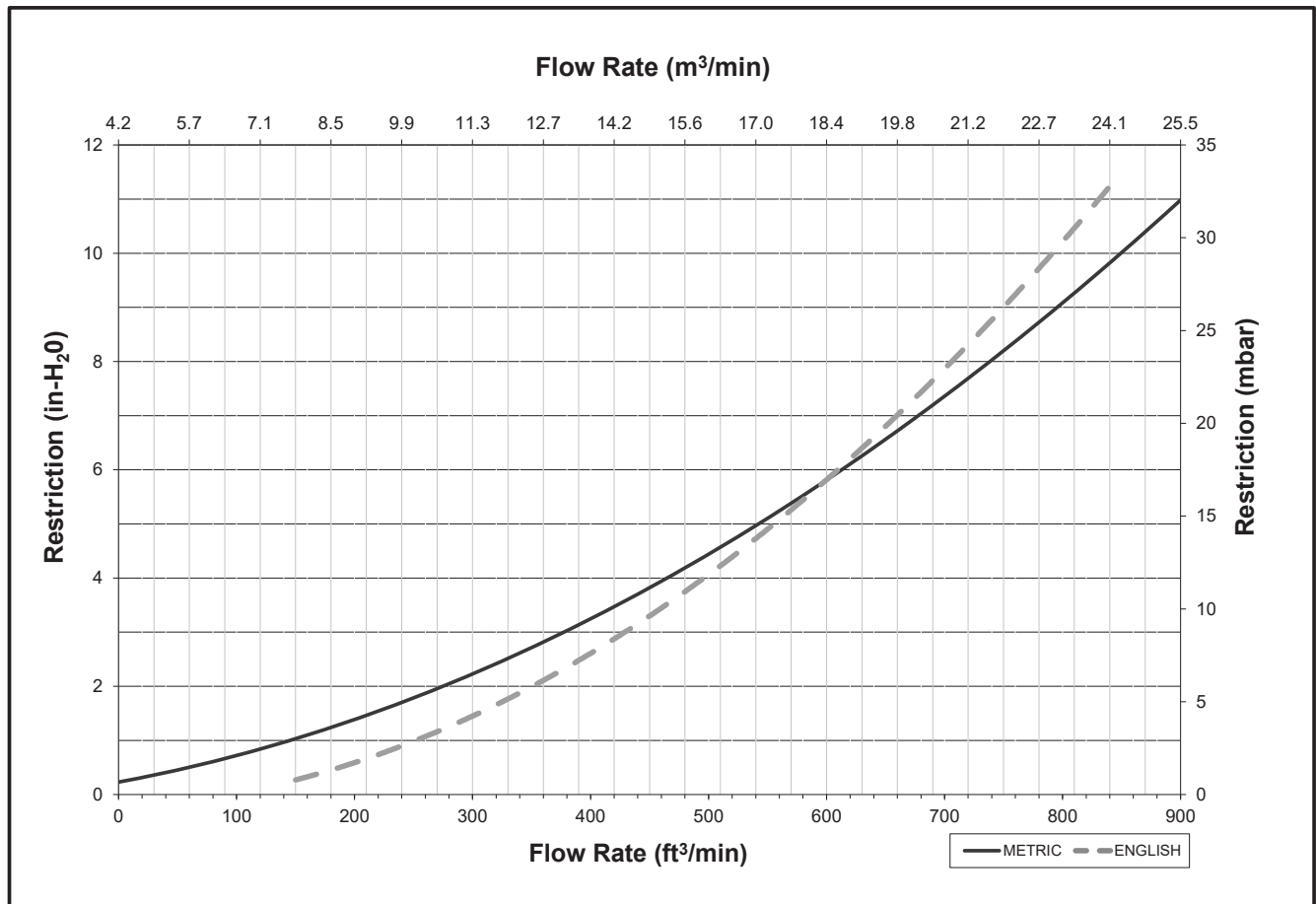

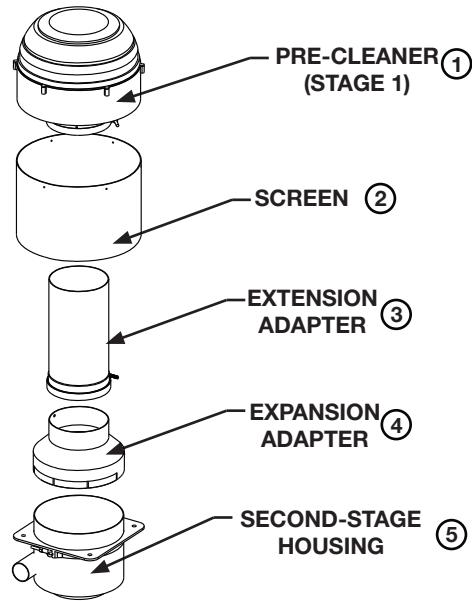

Specifications

Specification	AP85047
Width, Overall	12.5" (Ø 317.5 mm)
Height, Overall	31.5" (801.2 mm)
Application Flow Rate	500-650 CFM (14.16 - 18.41 m ³ /min)
Outlet Tube	6.0" (Ø 152.4 mm)

Dimensions

Specifications subject to change without notice.

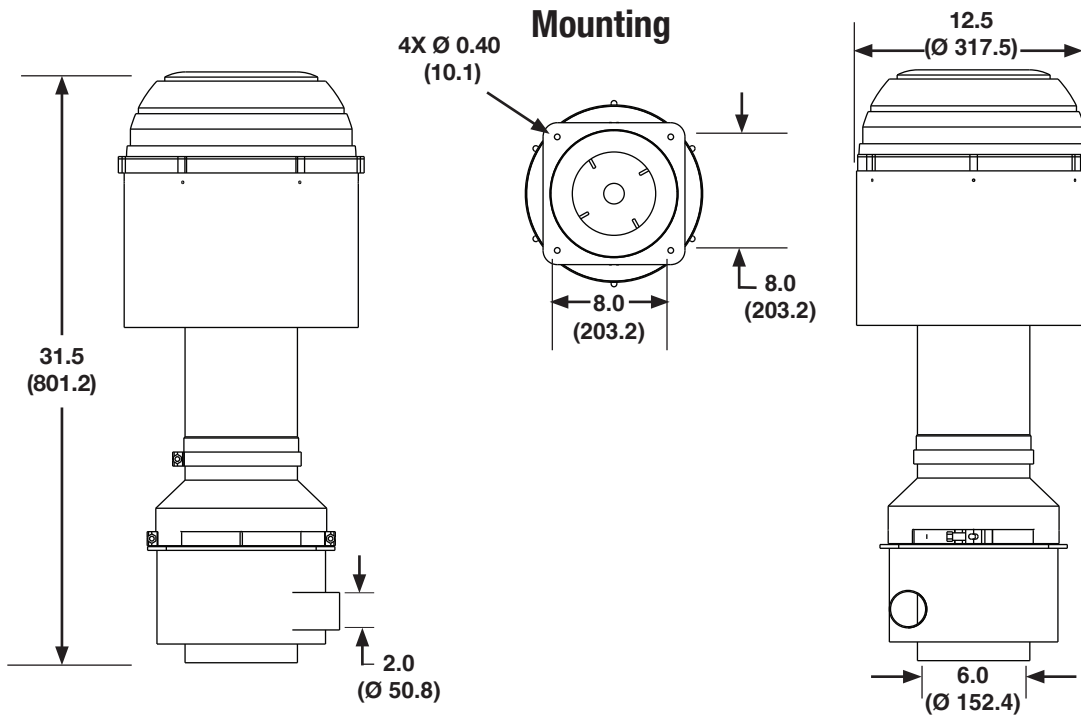

All dimensions are in inches (millimeters)

Ordering Information

Dual-Stage Pre-Cleaner	
Part Number	Description
AP85047	Dual-Stage Pre-Cleaner

Service Parts		
	Part Number	Description
①	AP08404	Pre-Cleaner
②	3946090S	Screen
③	3939411S	6" Extension Adapter
④	3939412S	6" to 9" Expansion Adapter
⑤	3953525S	Second-Stage Housing

Performance

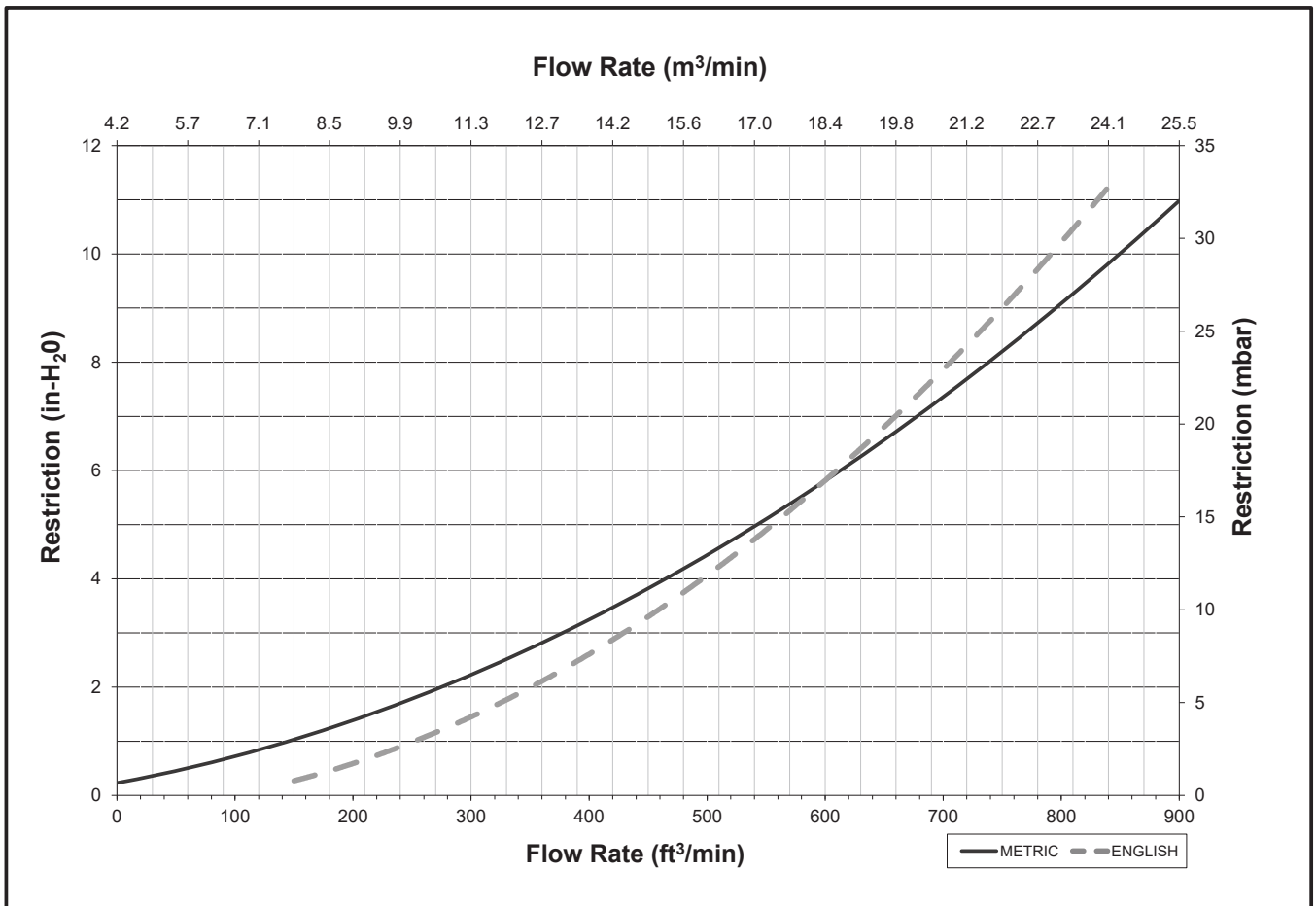

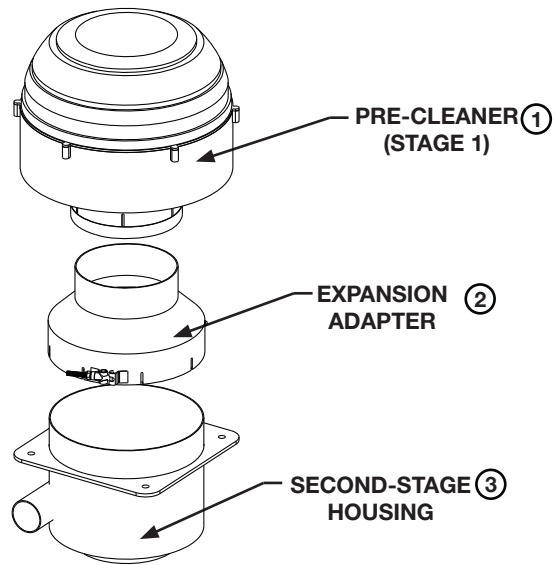

Specifications

Specification	AP85101
Width, Overall	12.5" (Ø 317.5 mm)
Height, Overall	22.3" (566.7 mm)
Application Flow Rate	650-800 CFM (18.41 - 22.65 m ³ /min)
Outlet Tube	6.0" (Ø 152.4 mm)

Specifications subject to change without notice.

Dimensions

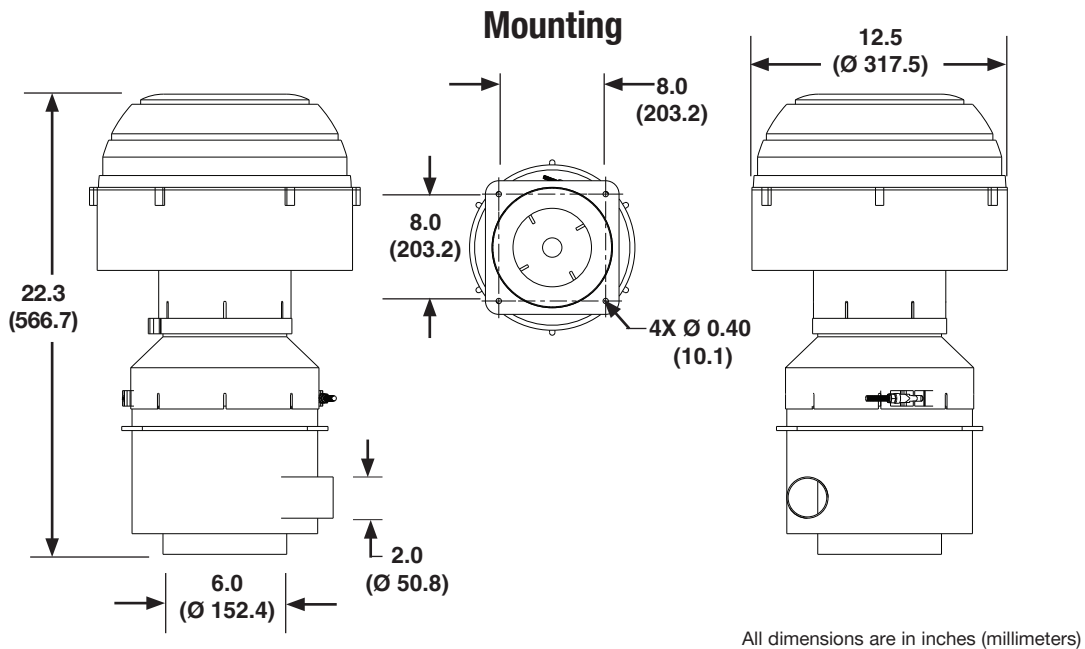

All dimensions are in inches (millimeters)

Ordering Information

Dual-Stage Pre-Cleaner	
Part Number	Description
AP85101	Dual-Stage Pre-Cleaner

Service Parts		
	Part Number	Description
①	AP08410	Pre-Cleaner
②	3939412S	6" to 9" Expansion Adapter
③	3953525S	Second-Stage Housing

Performance

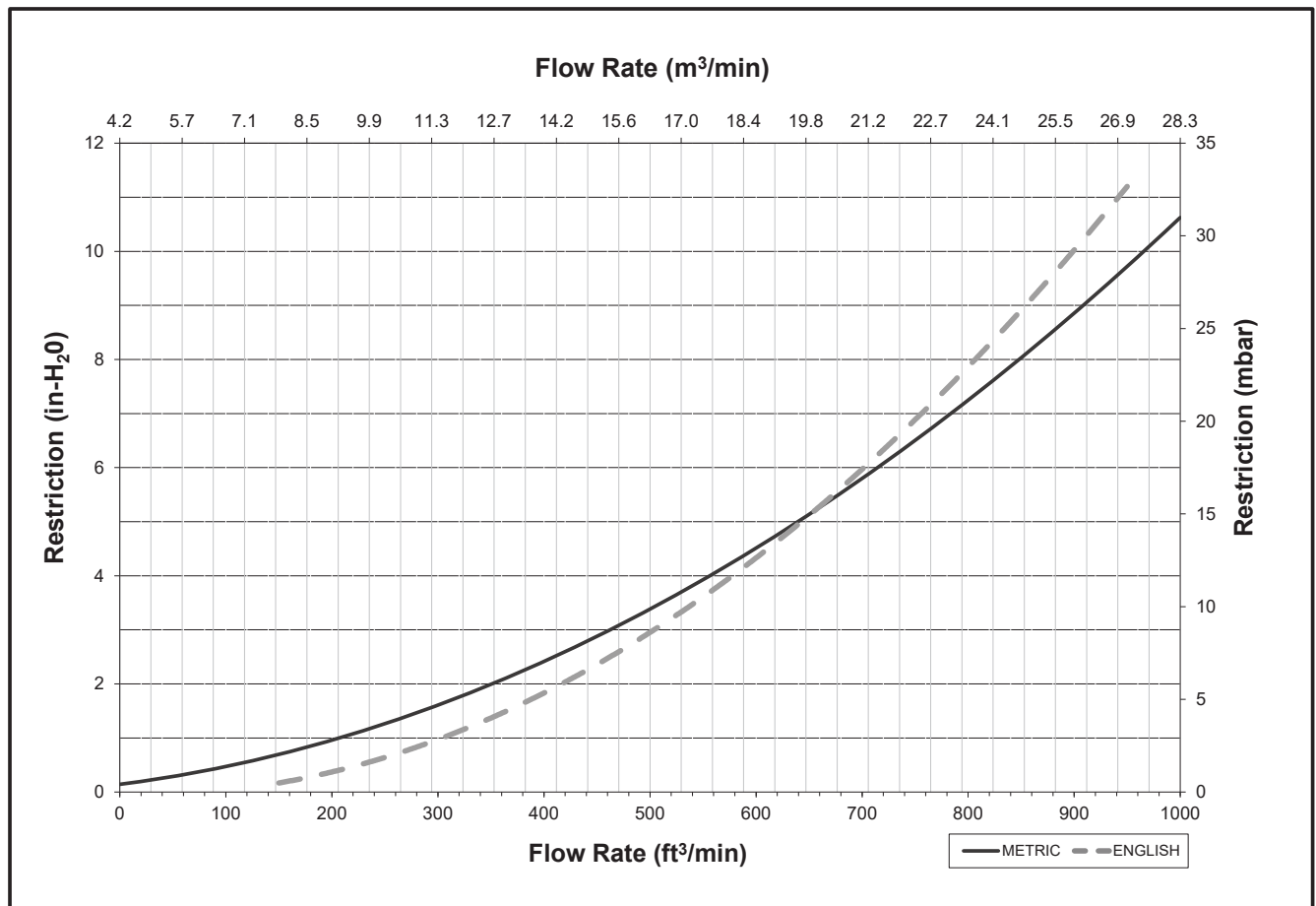

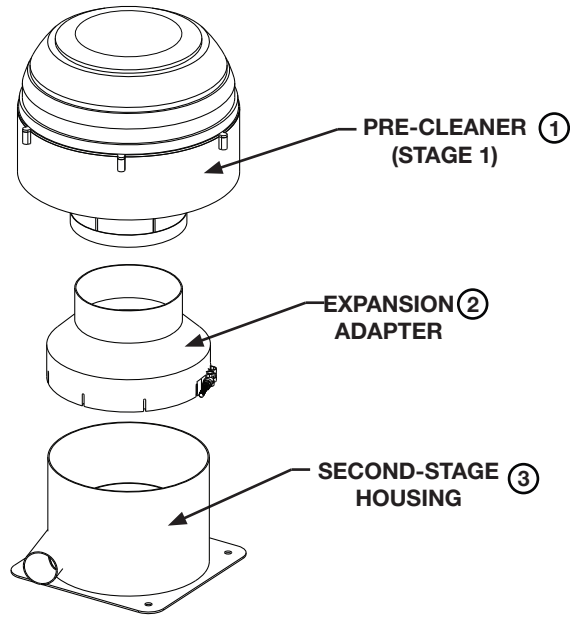

Specifications

Specification	AP85102
Width, Overall	12.5" (Ø 317.5 mm)
Height, Overall	21.1" (537.4 mm)
Application Flow Rate	650-800 CFM (18.41 - 22.65 m ³ /min)
Outlet Tube	6.0" (Ø 152.4 mm)

Specifications subject to change without notice.

Dimensions

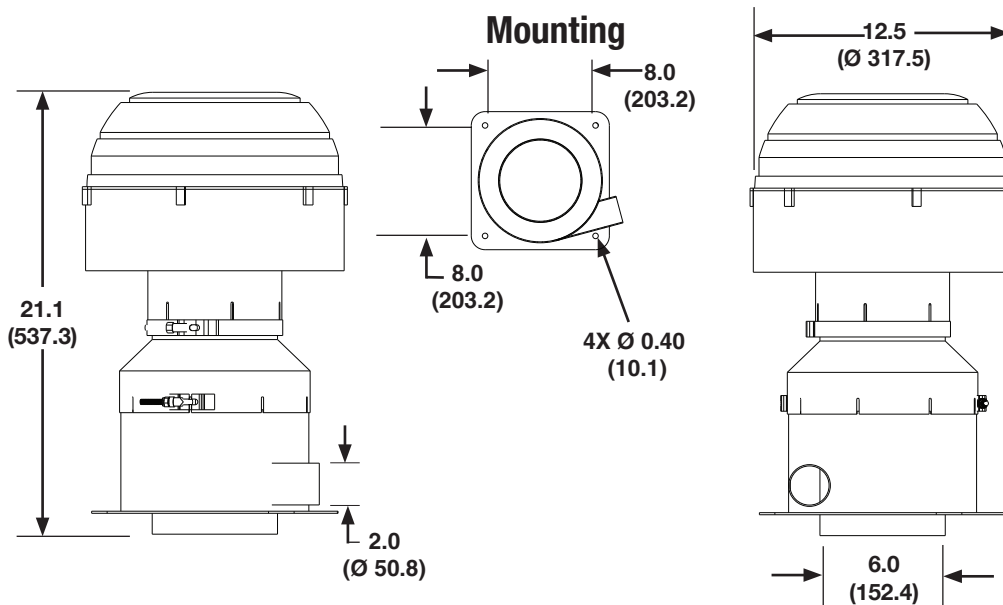

All dimensions are in inches (millimeters)

Ordering Information

Dual-Stage Pre-Cleaner	
Part Number	Description
AP85102	Dual-Stage Pre-Cleaner

Service Parts		
	Part Number	Description
①	AP8410	Pre-Cleaner
②	3939412S	6" to 9" Expansion Adapter
③	3953526S	Second-Stage Housing

Performance

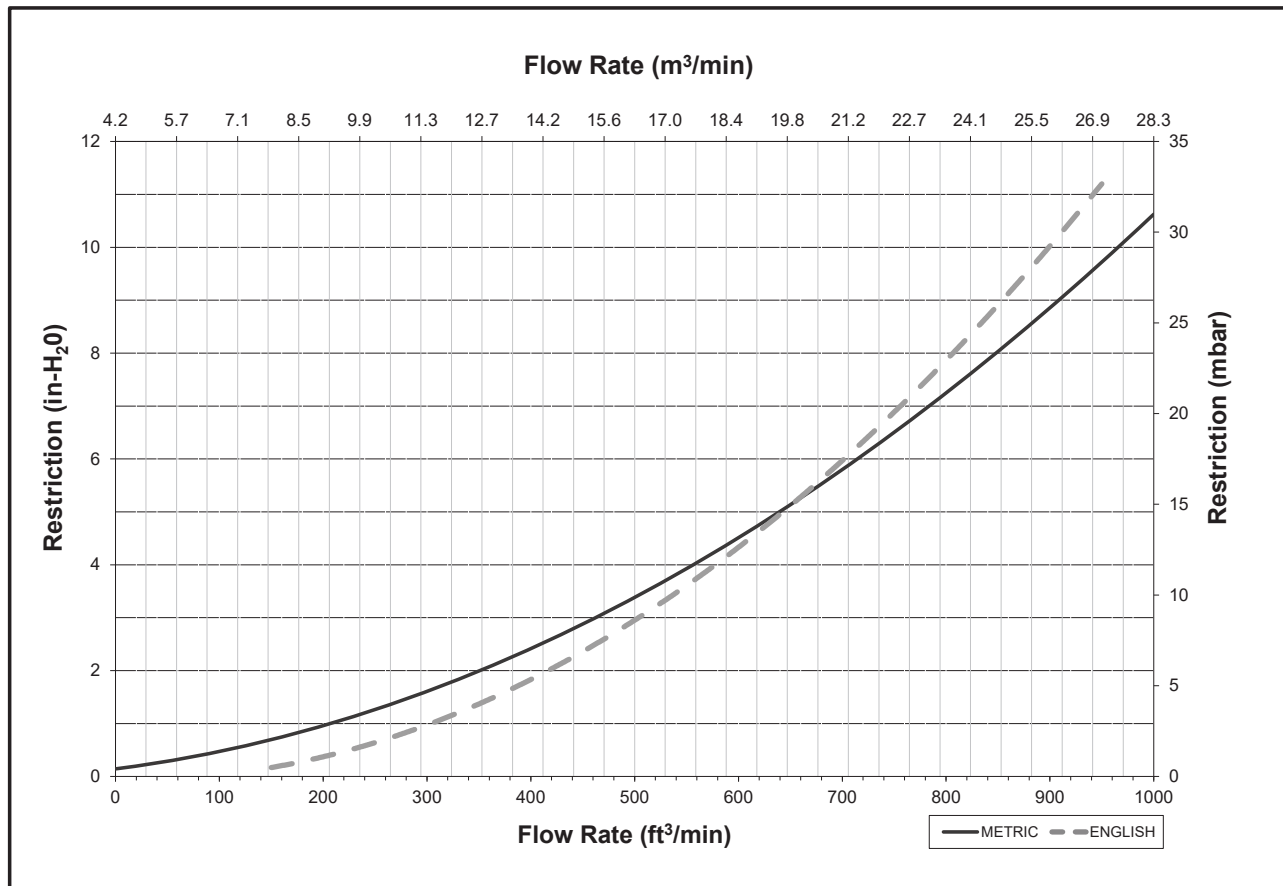

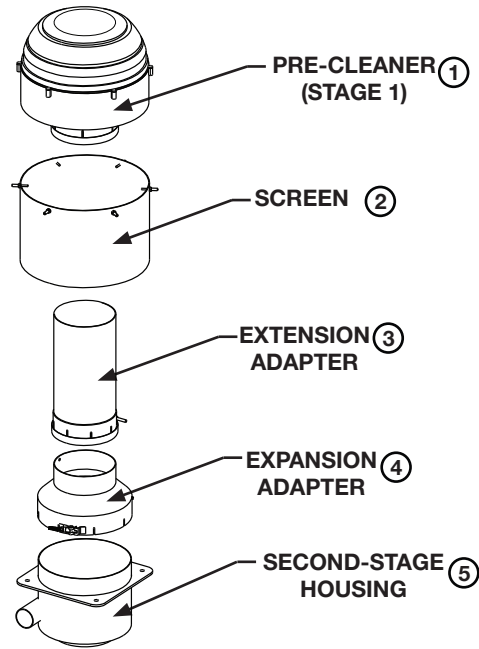

Specifications

Specification	AP85104
Width, Overall	12.5" (Ø 317.5 mm)
Height, Overall	32.9" (836.9 mm)
Application Flow Rate	650-800 CFM (18.41 - 22.65 m ³ /min)
Outlet Tube	6.0" (Ø 152.4 mm)

Dimensions

Specifications subject to change without notice.

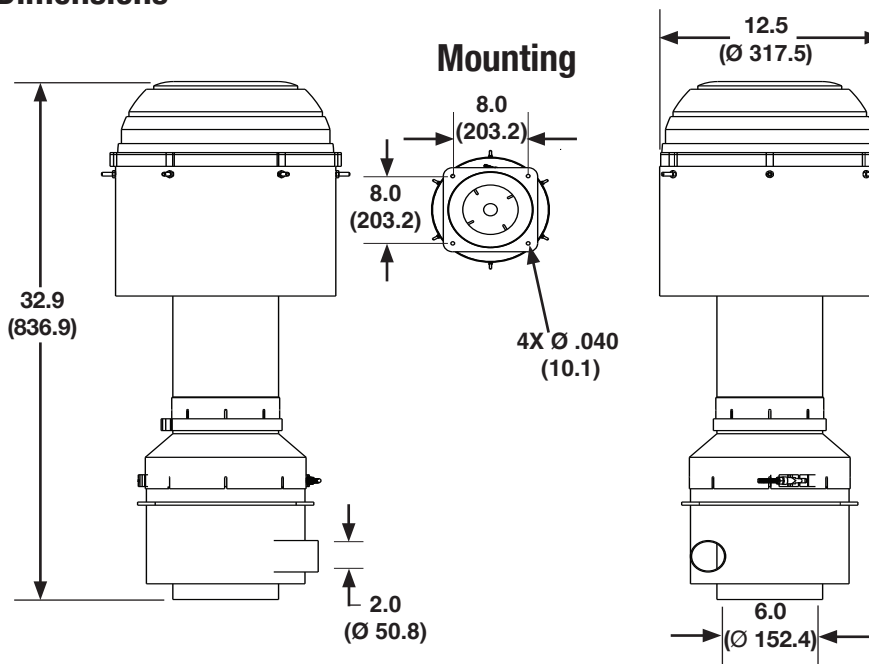

All dimensions are in inches (millimeters)

Ordering Information

Dual-Stage Pre-Cleaner	
Part Number	Description
AP85104	Dual-Stage Pre-Cleaner

Service Parts		
	Part Number	Description
①	AP8410	Pre-Cleaner
②	3946090S	Screen
③	3939411S	6" Extension Adapter
④	3939412S	6" to 9" Expansion Adapter
⑤	3953525S	Second-Stage Housing

Performance

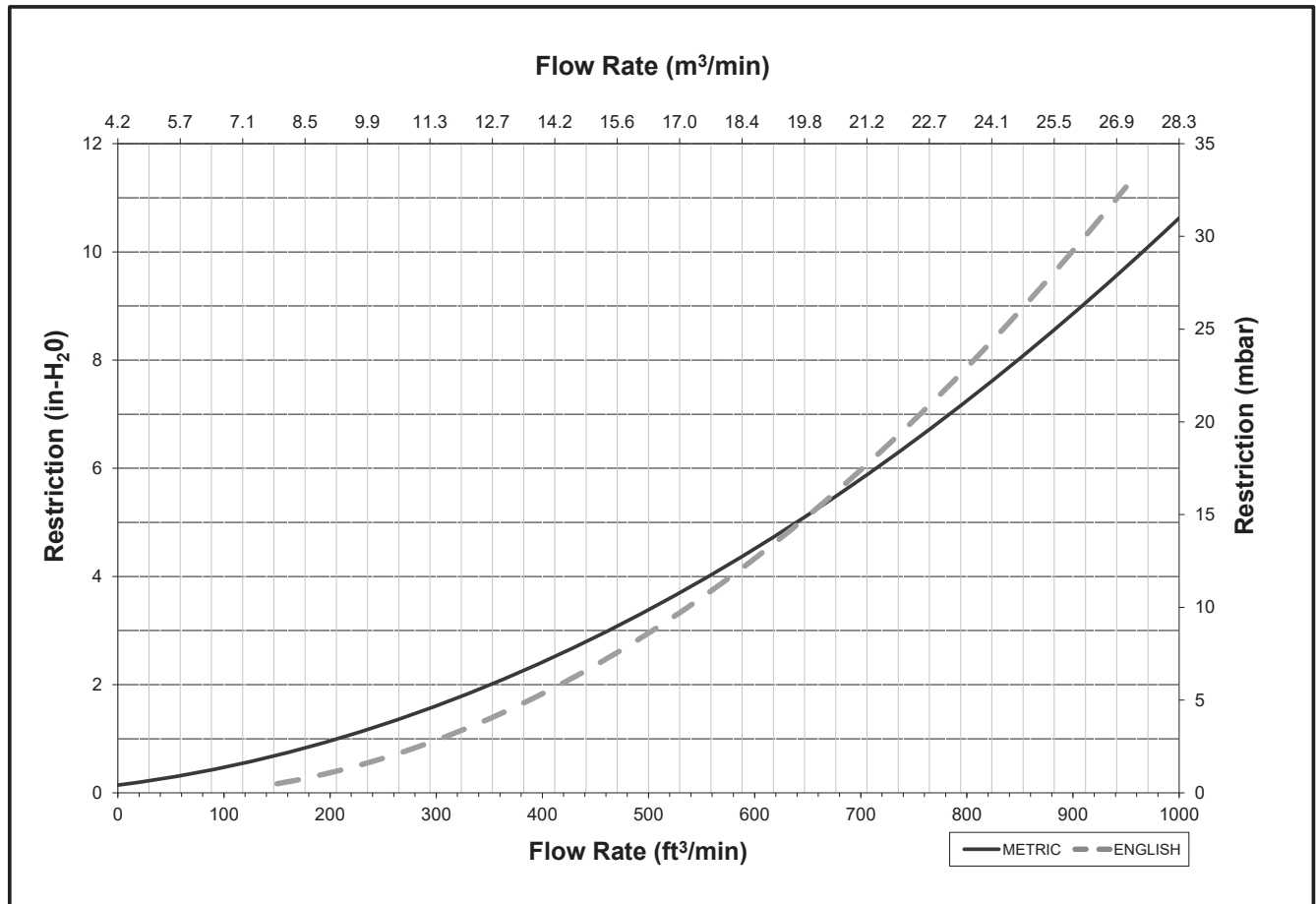

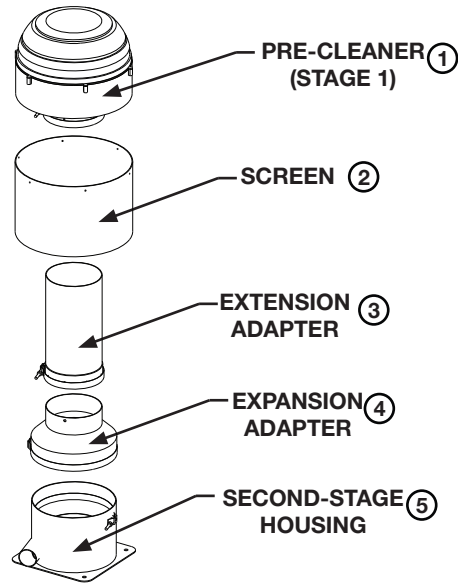

Specifications

Specification	AP85105
Width, Overall	12.5" (Ø 317.5 mm)
Height, Overall	30.8" (783.1 mm)
Application Flow Rate	650-800 CFM (18.41 - 22.65 m ³ /min)
Outlet Tube	6.0" (Ø 152.4 mm)

Specifications subject to change without notice.

Dimensions

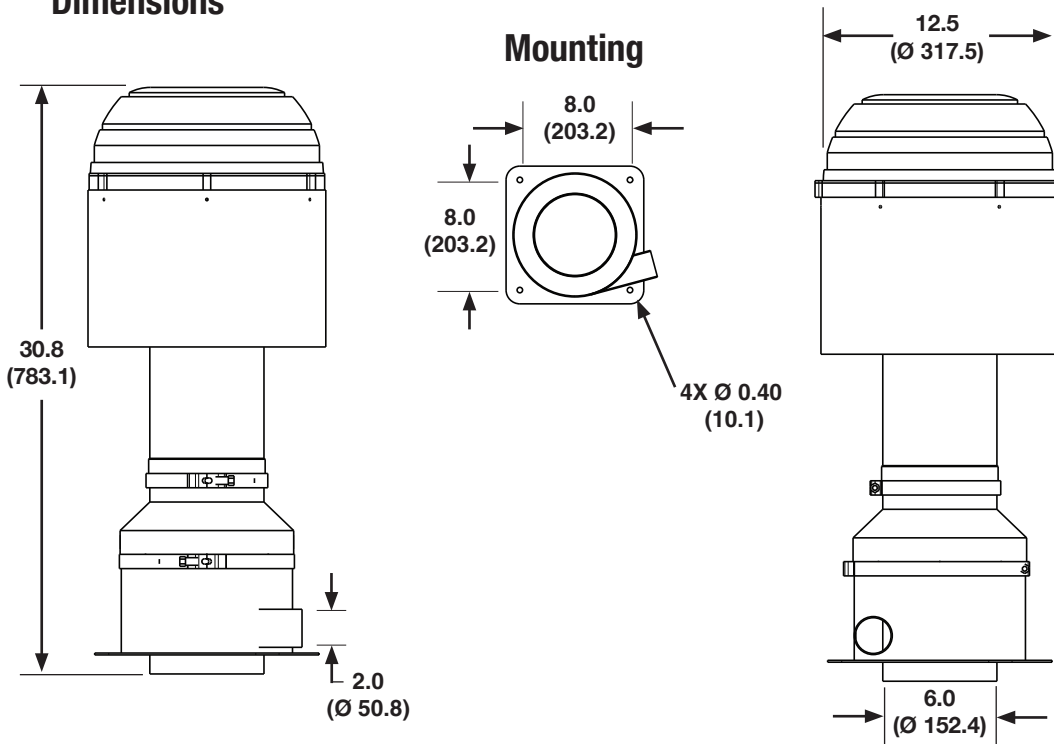

All dimensions are in inches (millimeters)

Ordering Information

Dual-Stage Pre-Cleaner	
Part Number	Description
AP85105	Dual-Stage Pre-Cleaner

Service Parts		
	Part Number	Description
①	AP8410	Pre-Cleaner
②	3946090S	Screen
③	3939411S	6" Extension Adapter
④	3939412S	6" to 9" Expansion Adapter
⑤	3953526S	Second-Stage Housing

Performance

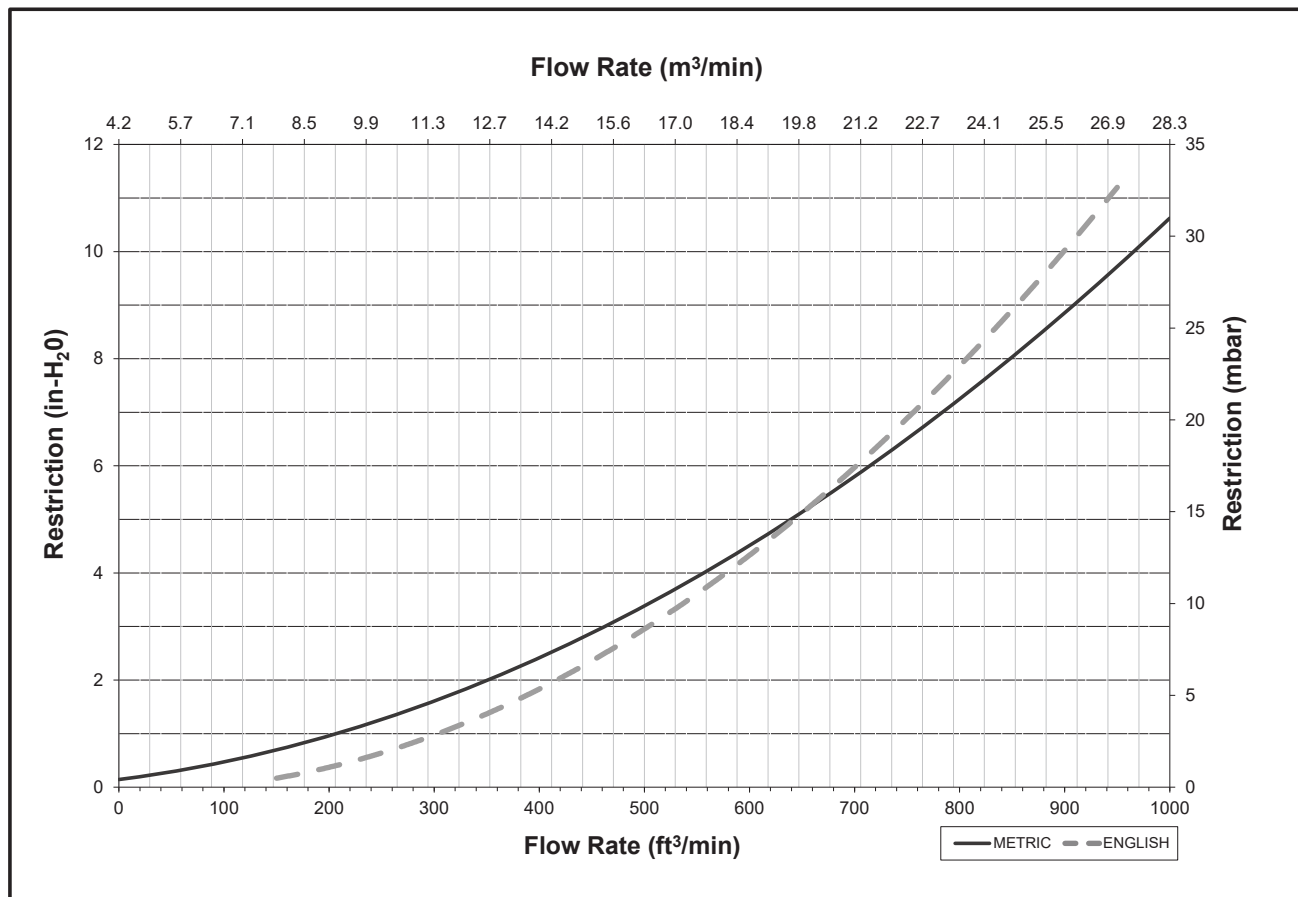

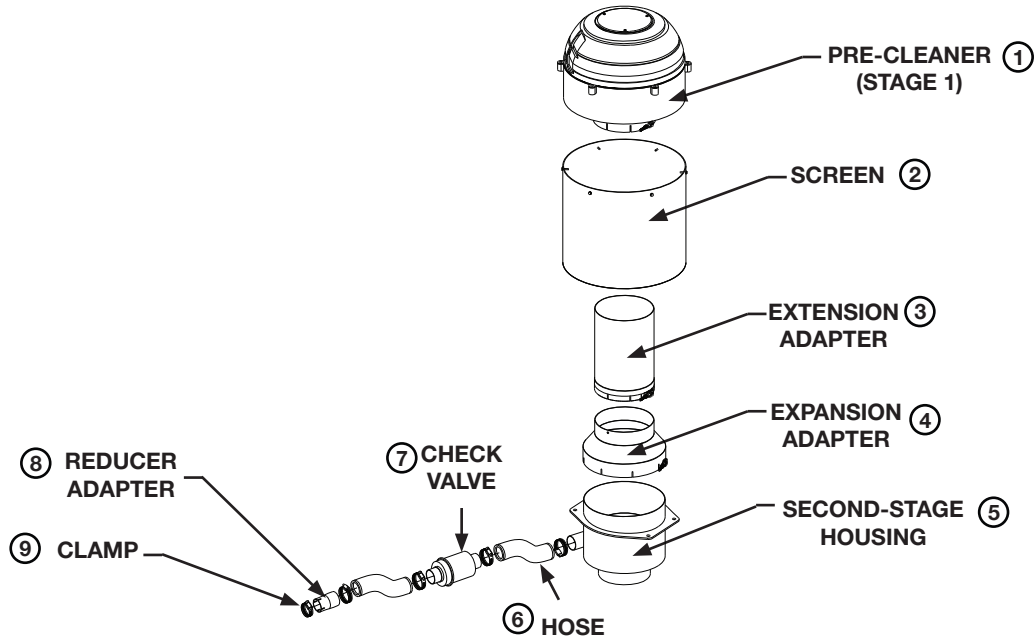

Specifications

Specification	AP85051
Width, Overall	16.6" (Ø 421.6 mm)
Height, Overall	39.7" (1008.5 mm)
Application Flow Rate	800-1150 CFM (22.65 - 32.56 m ³ /min)
Outlet Tube	7" (Ø 177.8 mm)

Specifications subject to change without notice.

Dimensions

Mounting

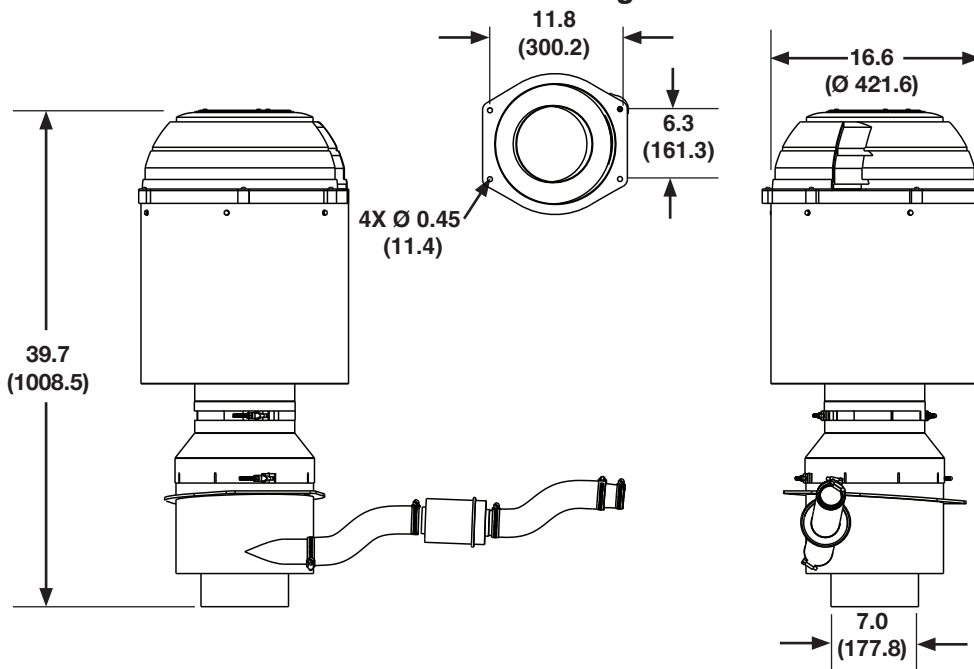

All dimensions are in inches (millimeters)

Ordering Information

Dual-Stage Pre-Cleaner	
Part Number	Description
AP85051	Dual-Stage Pre-Cleaner

Service Parts		
	Part Number	Description
①	AP08405	Pre-Cleaner
②	3946089S	Screen
③	3946105S	8" Extension Adapter
④	3918244S	8" to 11" Expansion Adapter
⑤	3953523S	Second-Stage Housing
⑥	3952359S	Hose
⑦	3953535S	Check Valve
⑧	3952334S	Reducer Adapter
⑨	3952353S	Clamp

Performance

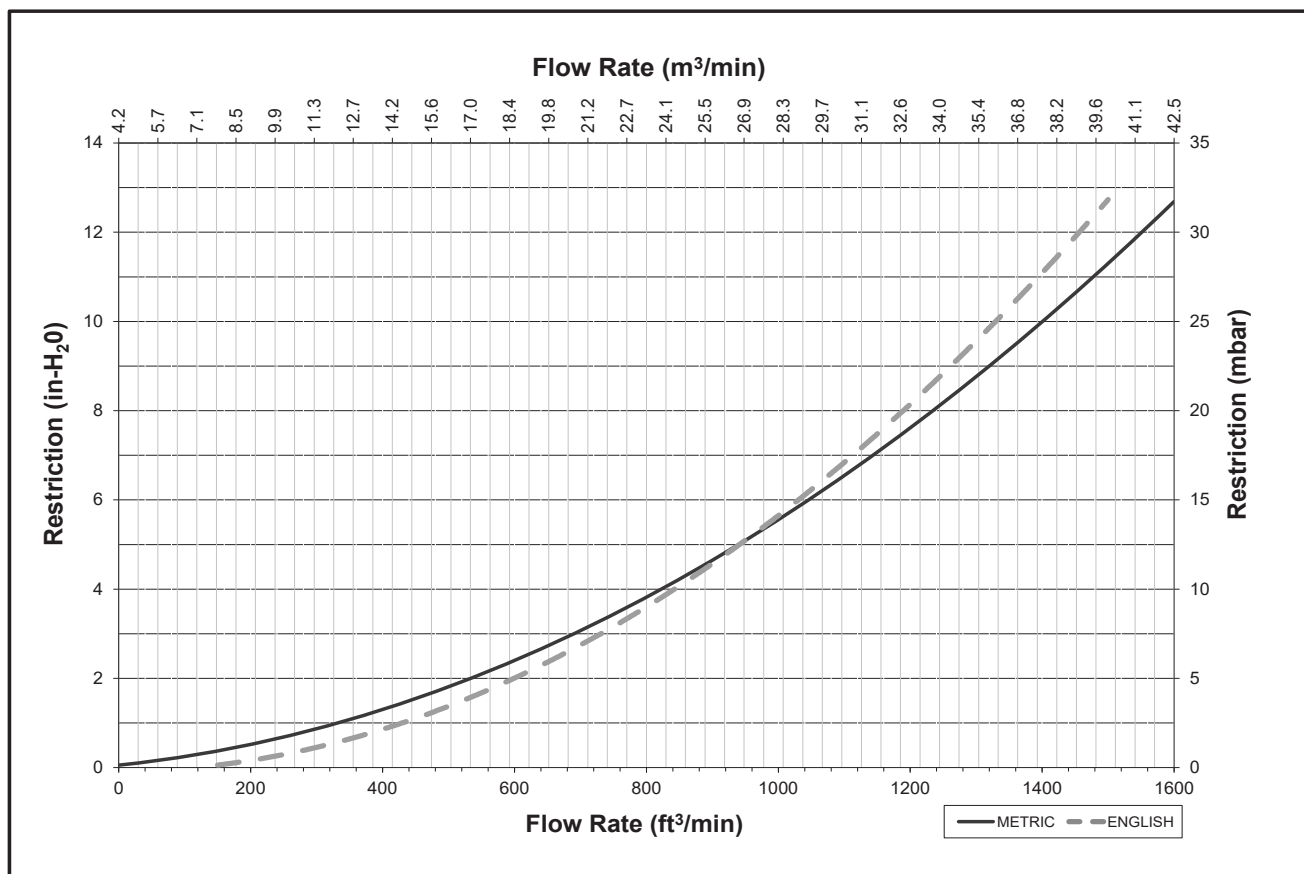

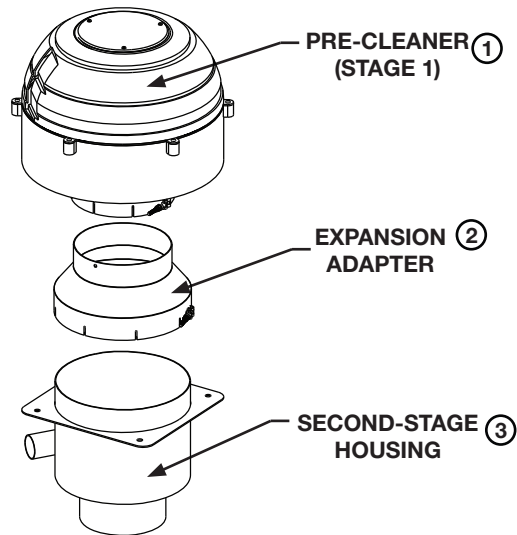

Specifications

Specification	AP85052
Width, Overall	16.6" (Ø 421.6 mm)
Height, Overall	30.1" (764.8 mm)
Application Flow Rate	800-1150 CFM (22.65 - 32.56 m ³ /min)
Outlet Tube	7.0" (Ø 177.8 mm)

Specifications subject to change without notice.

Dimensions

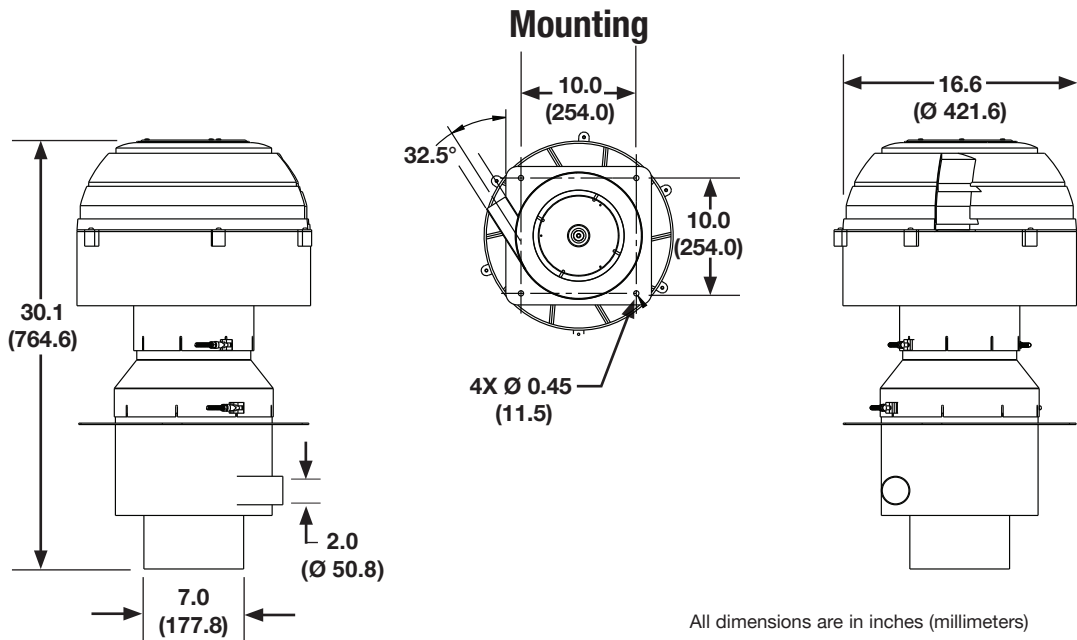

All dimensions are in inches (millimeters)

Ordering Information

Dual-Stage Pre-Cleaner	
Part Number	Description
AP85052	Dual-Stage Pre-Cleaner

Service Parts	
Part Number	Description
① AP08405	Pre-Cleaner
② 3918244S	8" to 11" Expansion Adapter
③ 3953527S	Second-Stage Housing

Performance

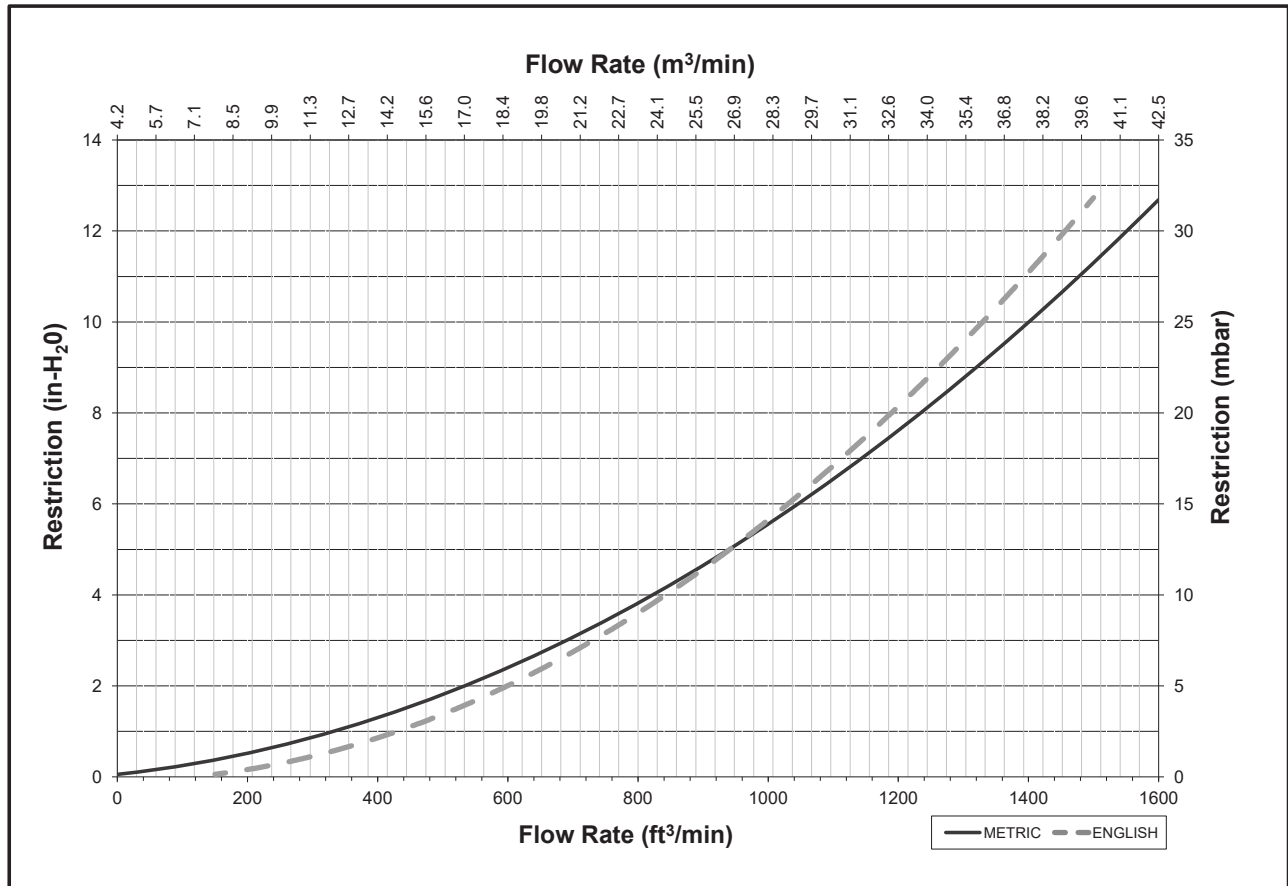

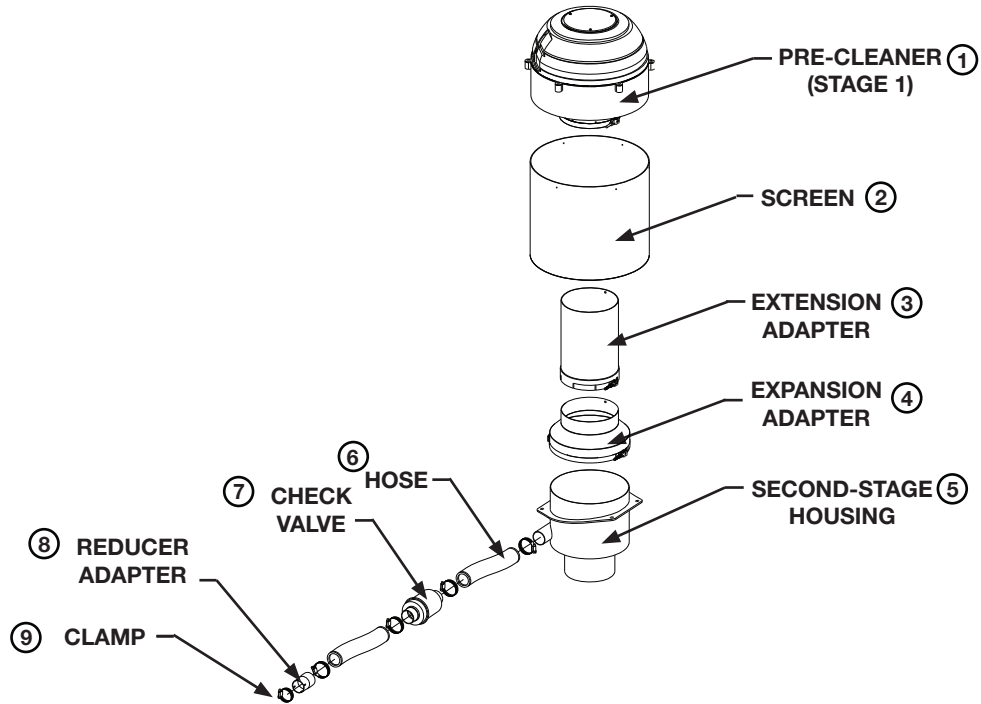

Specifications

Specification	AP85053
Width, Overall	16.6" (Ø 421.6 mm)
Height, Overall	41.3" (1049.0 mm)
Application Flow Rate	800-1150 CFM (22.65 - 32.56 m ³ /min)
Outlet Tube	7.0" (Ø 177.8 mm)

Specifications subject to change without notice.

Dimensions

Mounting

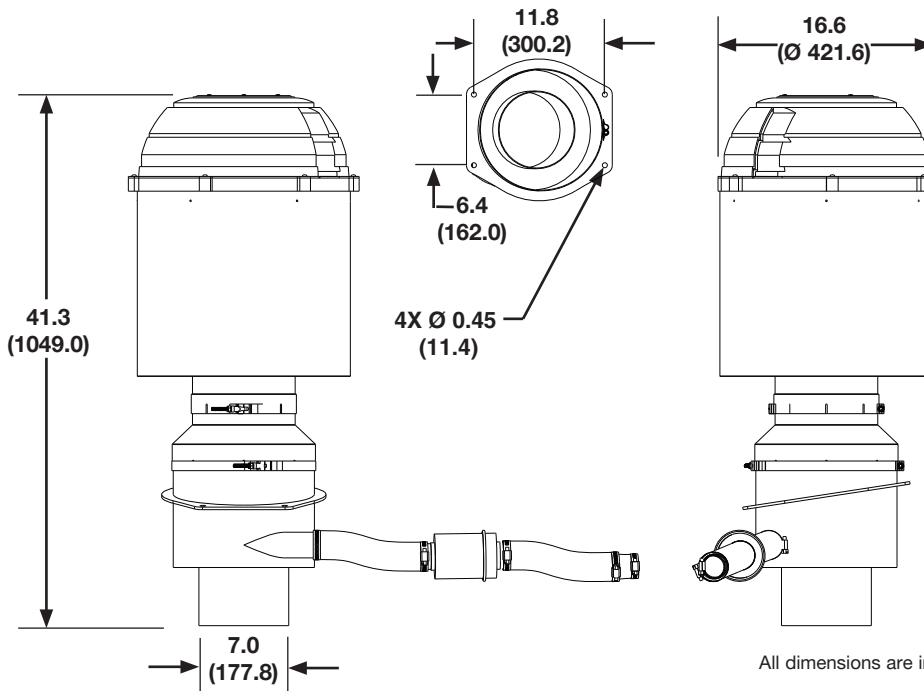

All dimensions are in inches (millimeters)

Ordering Information

Dual-Stage Pre-Cleaner	
Part Number	Description
AP85053	Dual-Stage Pre-Cleaner

Service Parts		
	Part Number	Description
①	AP8405	Pre-Cleaner
②	3946089S	Screen
③	3946105S	8" Extension Adapter
④	3918244S	8" to 11" Expansion Adapter
⑤	3953524S	Second-Stage Housing
⑥	3952359S	Hose
⑦	3953535S	Check Valve
⑧	3952334S	Reducer Adapter
⑨	3952353S	Clamp

Performance

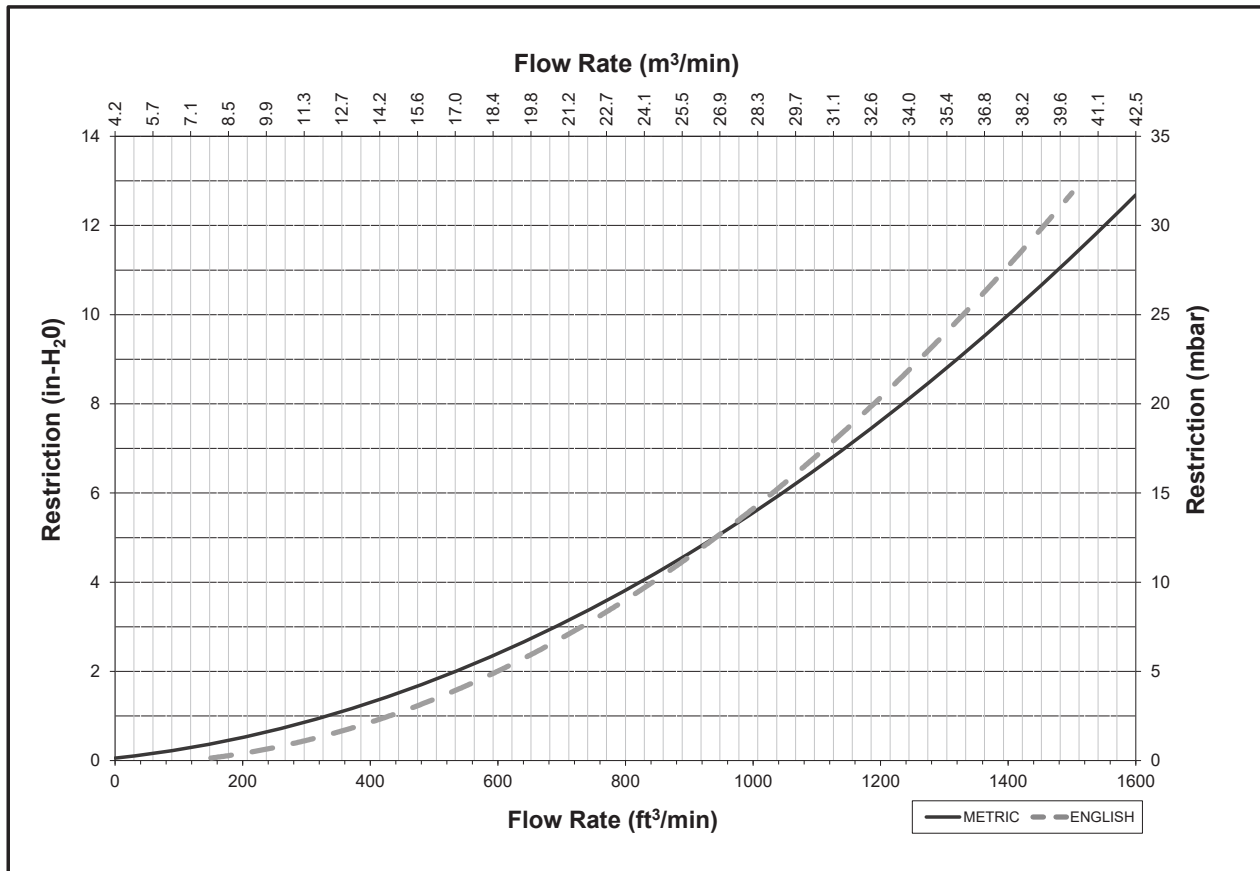

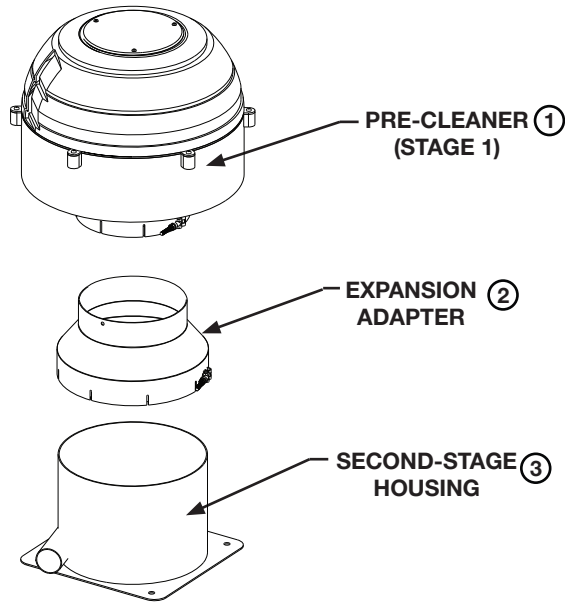

Specifications

Specification	AP85054
Width, Overall	16.4" (Ø 416.4 mm)
Height, Overall	26.7" (677.6 mm)
Application Flow Rate	800-1150 CFM (22.65 - 32.56 m ³ /min)
Outlet Tube	7.0" (Ø 177.8 mm)

Dimensions

Specifications subject to change without notice.

Mounting

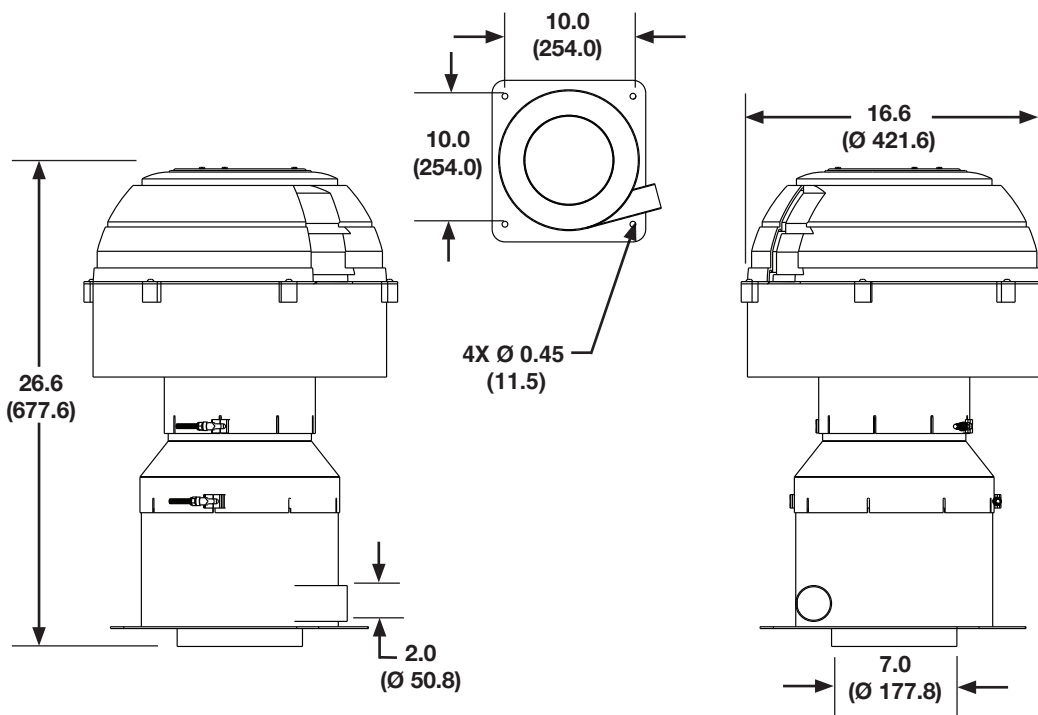

All dimensions are in inches (millimeters)

Ordering Information

Dual-Stage Pre-Cleaner	
Part Number	Description
AP85054	Dual-Stage Pre-Cleaner

Service Parts		
	Part Number	Description
①	AP8405	Pre-Cleaner
②	3918244S	8" to 11" Expansion Adapter
③	3953528S	Second-Stage Housing

Performance

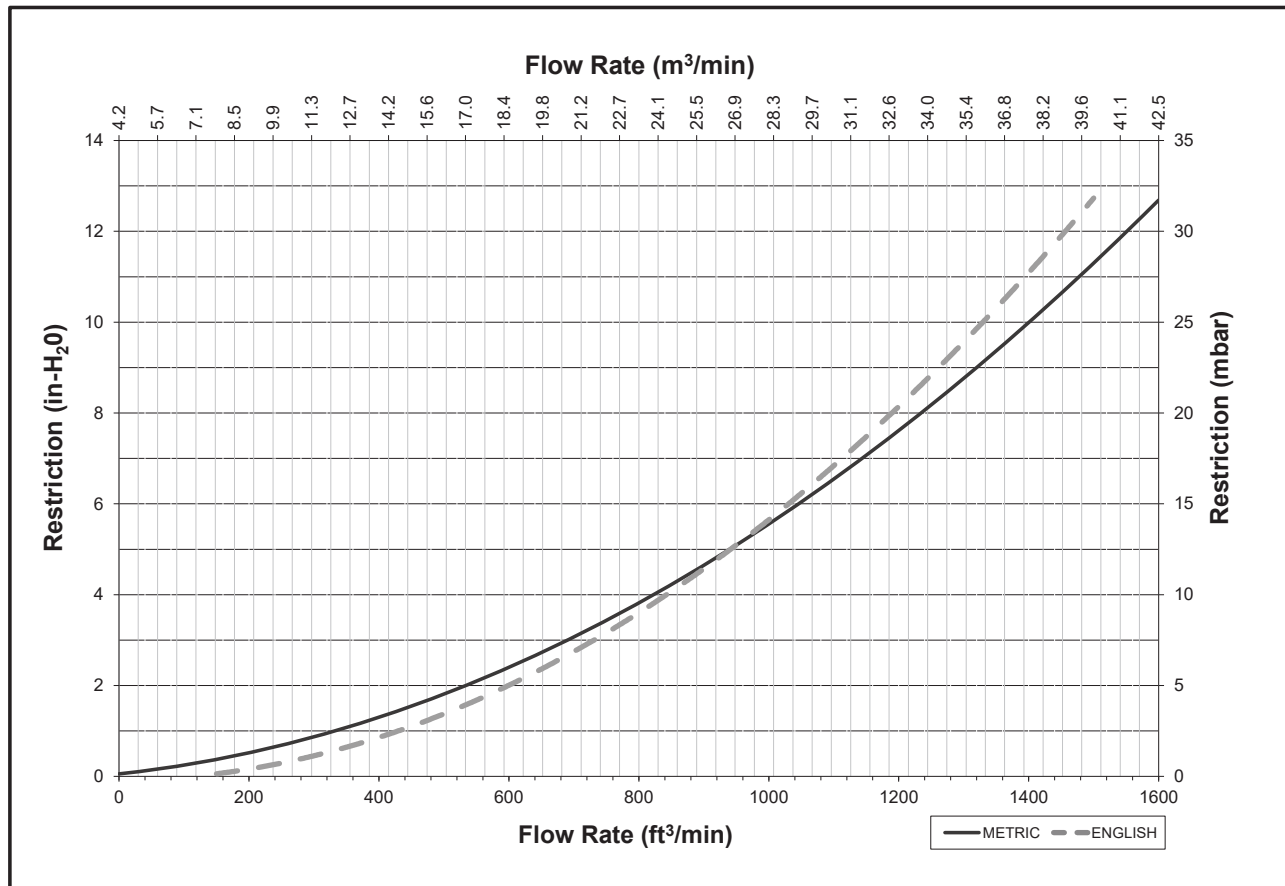

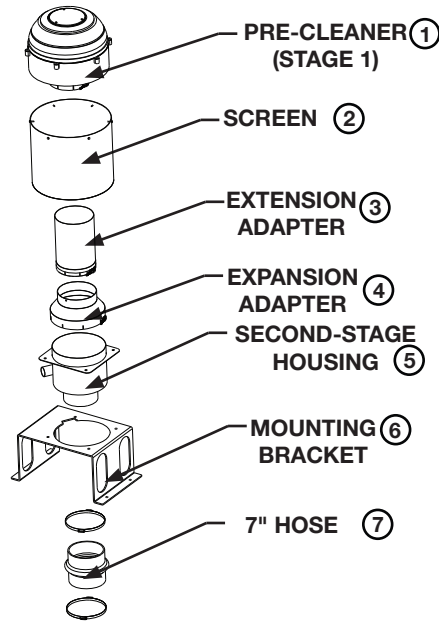

Specifications

Specification	AP85055
Width, Overall	16.6" (Ø 421.6 mm)
Height, Overall	44.9" (1140.7 mm)
Application Flow Rate	800-1150 CFM (22.65 - 32.56 m³/min)
Outlet Tube	7.0" (Ø 177.8 mm)

Specifications subject to change without notice.

Dimensions

Mounting

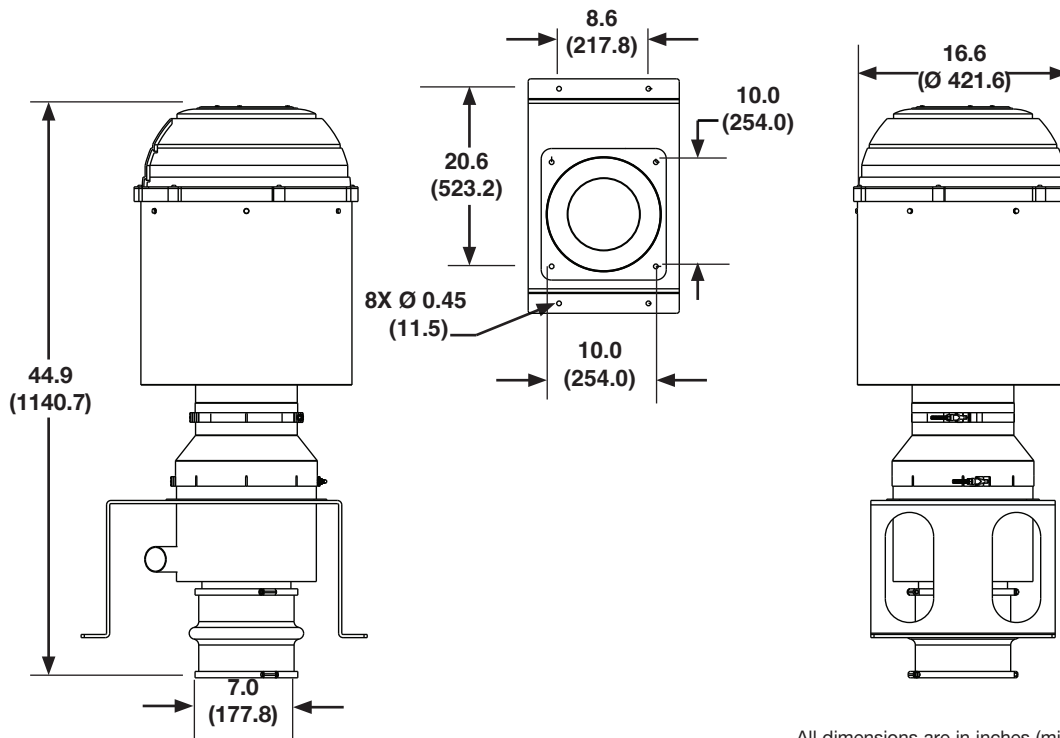

All dimensions are in inches (millimeters)

Ordering Information

Dual-Stage Pre-Cleaner	
Part Number	Description
AP85055	Dual-Stage Pre-Cleaner

Service Parts		
	Part Number	Description
①	AP08405	Pre-Cleaner
②	3946089S	Screen
③	3946105S	8" Extension Adapter
④	3918244S	8" to 11" Expansion Adapter
⑤	3953527S	Second-Stage Housing
⑥	3953533S	Mounting Bracket
⑦	3952351S	7" Hose

Performance

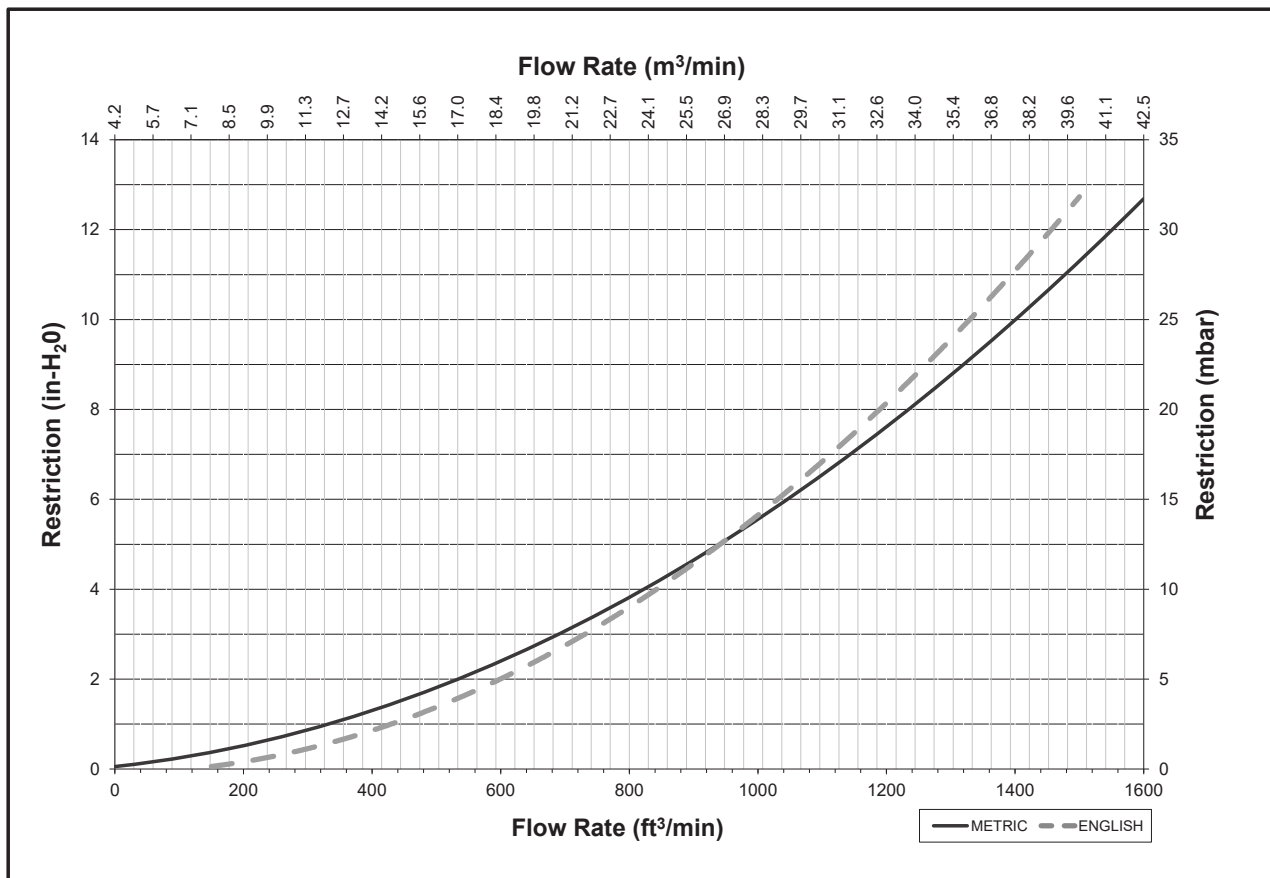

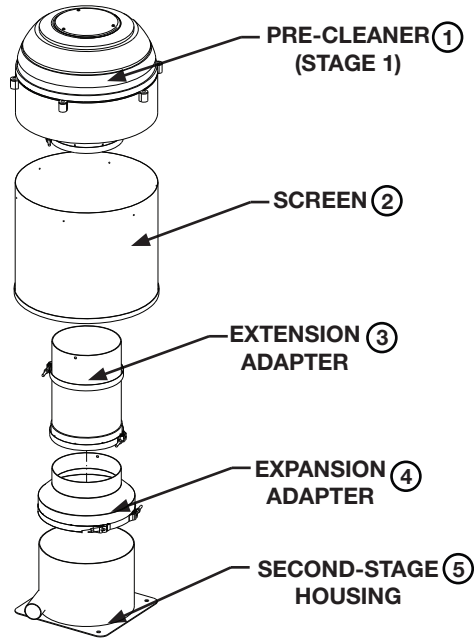

Specifications

Specification	AP85057
Width, Overall	16.6" (Ø 421.6 mm)
Height, Overall	36.7" (931.7 mm)
Application Flow Rate	800-1150 CFM (22.65 - 32.56 m³/min)
Outlet Tube	7.0" (Ø 177.8 mm)

Specifications subject to change without notice.

Dimensions

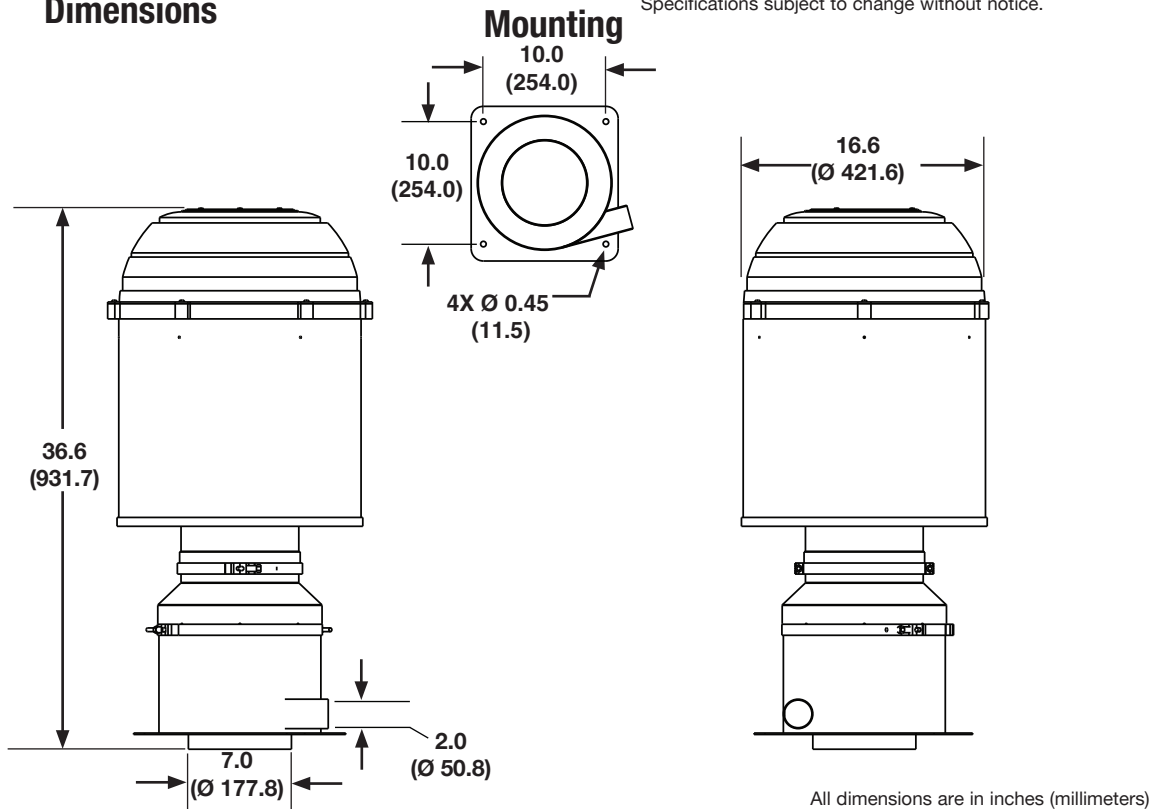

All dimensions are in inches (millimeters)

Ordering Information

Dual-Stage Pre-Cleaner	
Part Number	Description
AP85057	Dual-Stage Pre-Cleaner

Service Parts		
	Part Number	Description
①	AP8405	Pre-Cleaner
②	3946089S	Screen
③	3946105S	8" Extension Adapter
④	3918244S	8" to 11" Expansion Adapter
⑤	3953528S	Second-Stage Housing

Performance

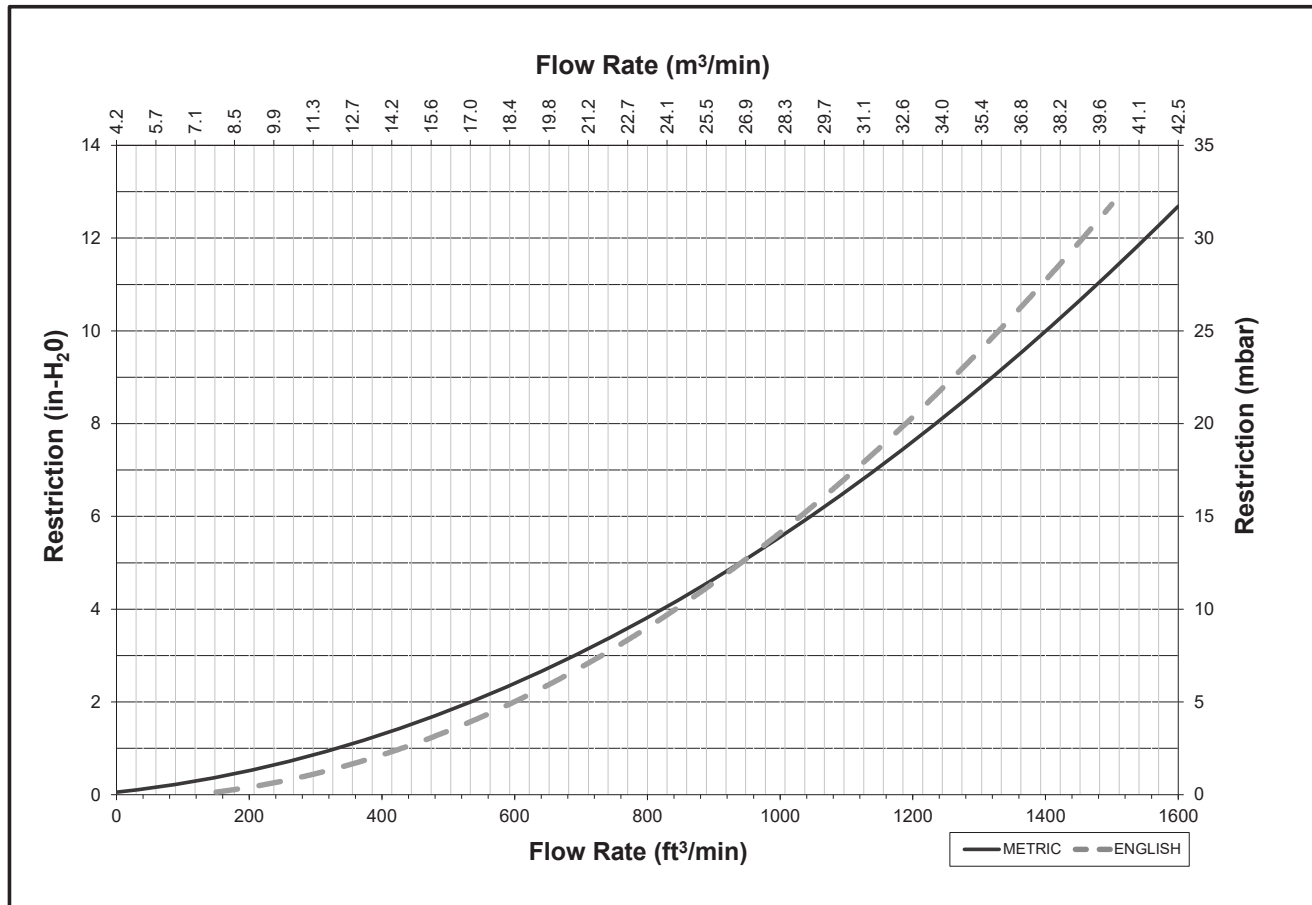

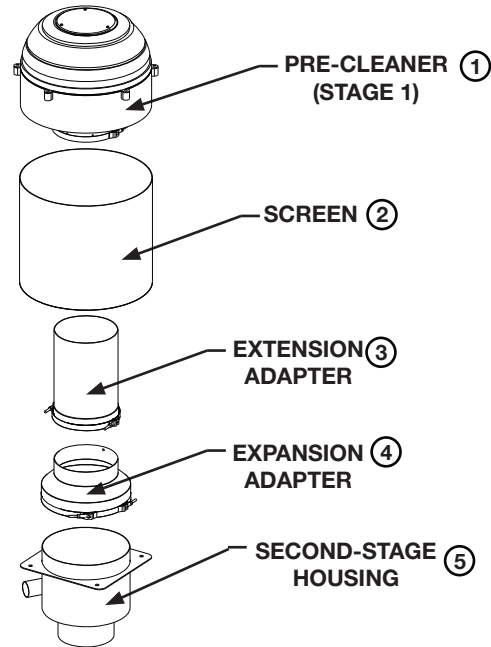

Specifications

Specification	AP85058
Width, Overall	16.6" (Ø 421.6 mm)
Height, Overall	39.7" (1009.3 mm)
Application Flow Rate	800-1150 CFM (22.65 - 32.56 m ³ /min)
Outlet Tube	7" (Ø 177.8 mm)

Specifications subject to change without notice.

Dimensions

Mounting

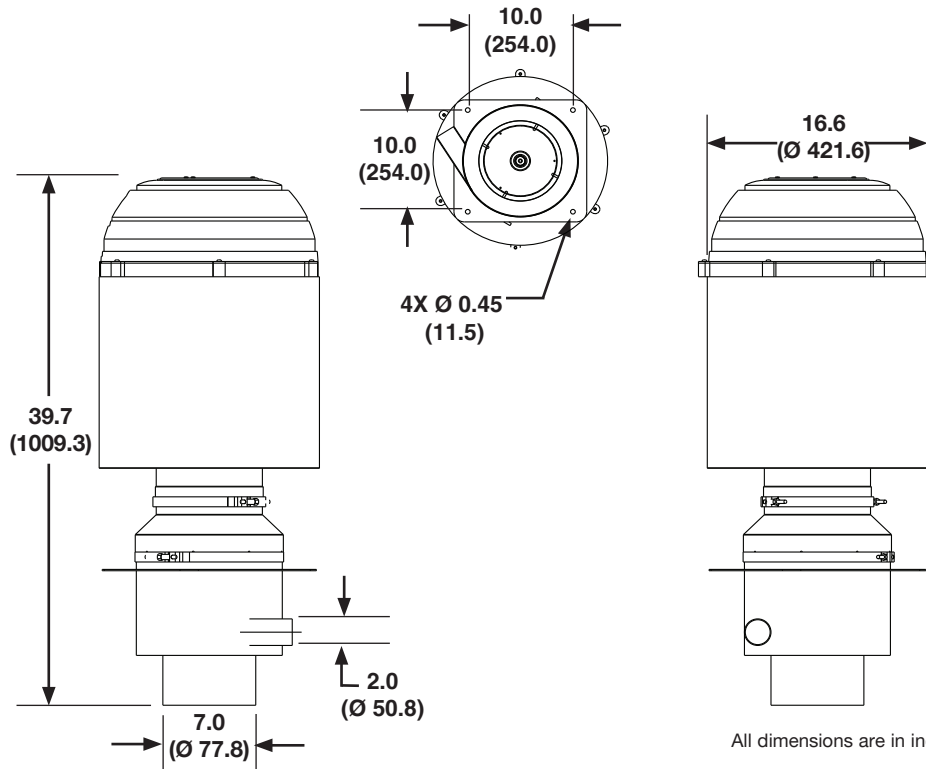

All dimensions are in inches (millimeters)

Ordering Information

Dual-Stage Pre-Cleaner	
Part Number	Description
AP85058	Dual-Stage Pre-Cleaner

Service Parts		
	Part Number	Description
①	AP8405	Pre-Cleaner
②	3946089S	Screen
③	3946105S	8" Extension Adapter
④	3918244S	8" to 11" Expansion Adapter
⑤	3953527S	Second-Stage Housing

Performance

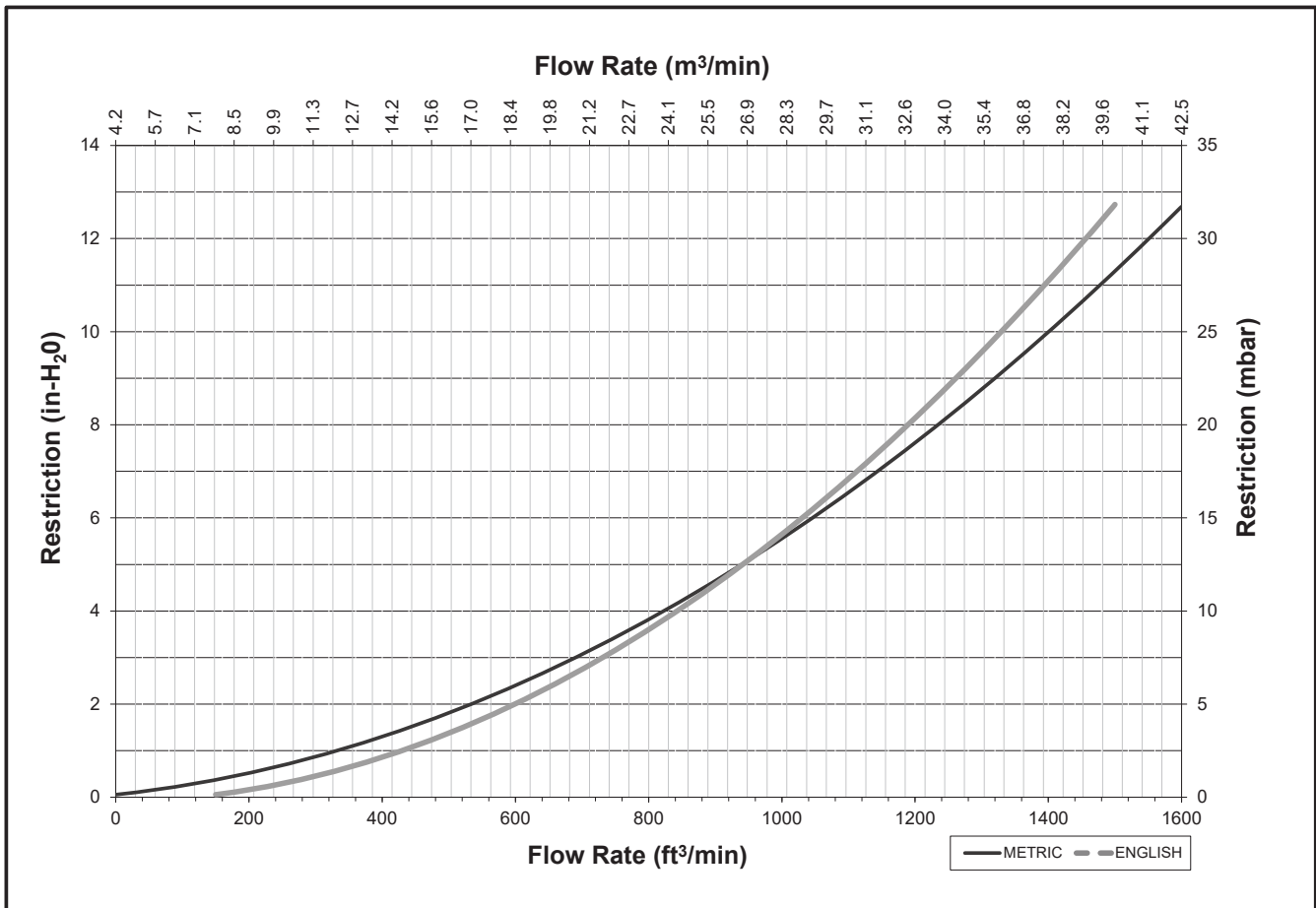

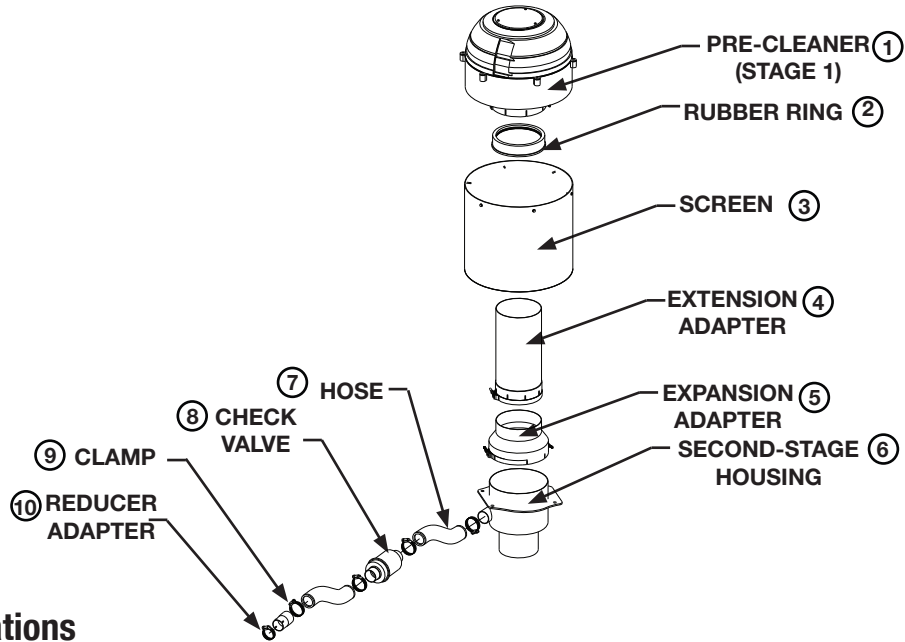

Specifications

Specification	AP85152
Width, Overall	16.6" (Ø 421.6 mm)
Height, Overall	43.3" (1102.1 mm)
Application Flow Rate	800-1150 CFM (22.65 - 32.56 m³/min)
Outlet Tube	6.0" (Ø 152.4 mm)

Specifications subject to change without notice.

Dimensions

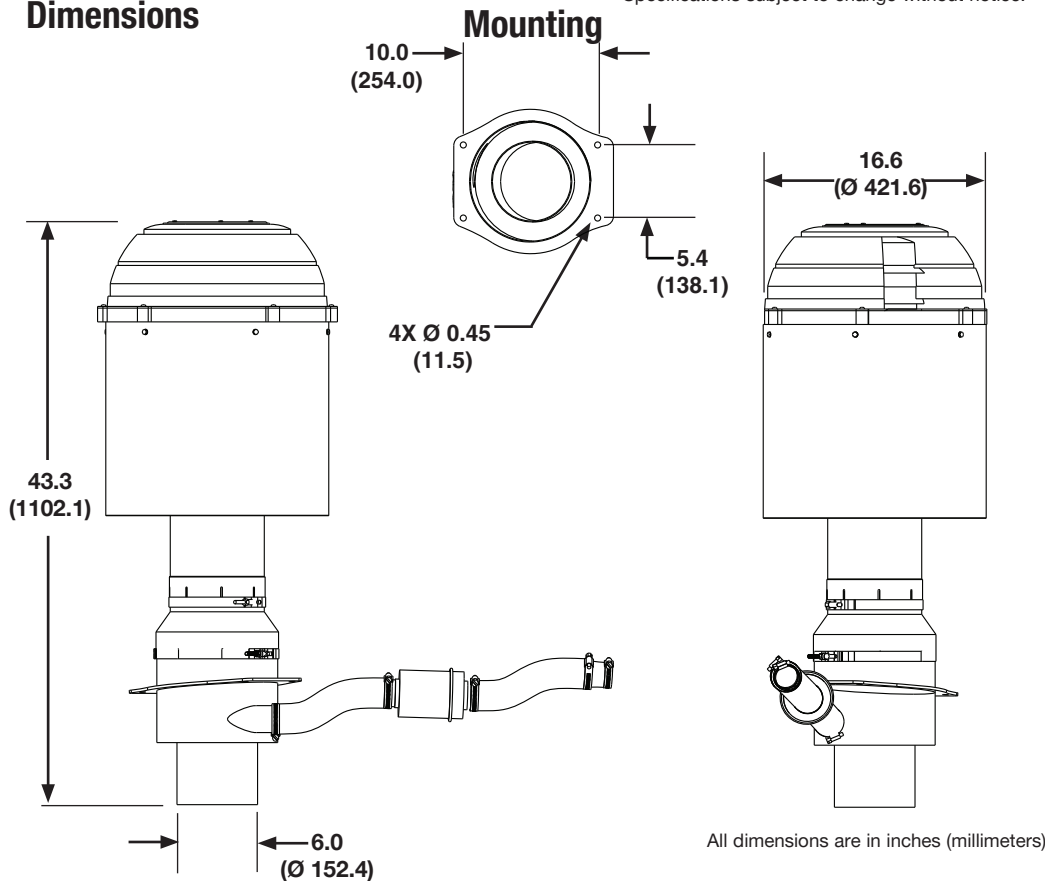

All dimensions are in inches (millimeters)

Ordering Information

Dual-Stage Pre-Cleaner	
Part Number	Description
AP85152	Dual-Stage Pre-Cleaner

Service Parts		
	Part Number	Description
①	AP8405	Pre-Cleaner
②	3918243S	8" to 7" Rubber Ring
③	3946089S	Screen
④	3946107S	8" Extension Adapter
⑤	3946109S	8" to 11" Expansion Adapter
⑥	3953522S	Second-Stage Housing
⑦	3952359S	Hose
⑧	3953535S	Check Valve
⑨	3952353S	Clamp
⑩	3952334S	Reducer Adapter

Performance

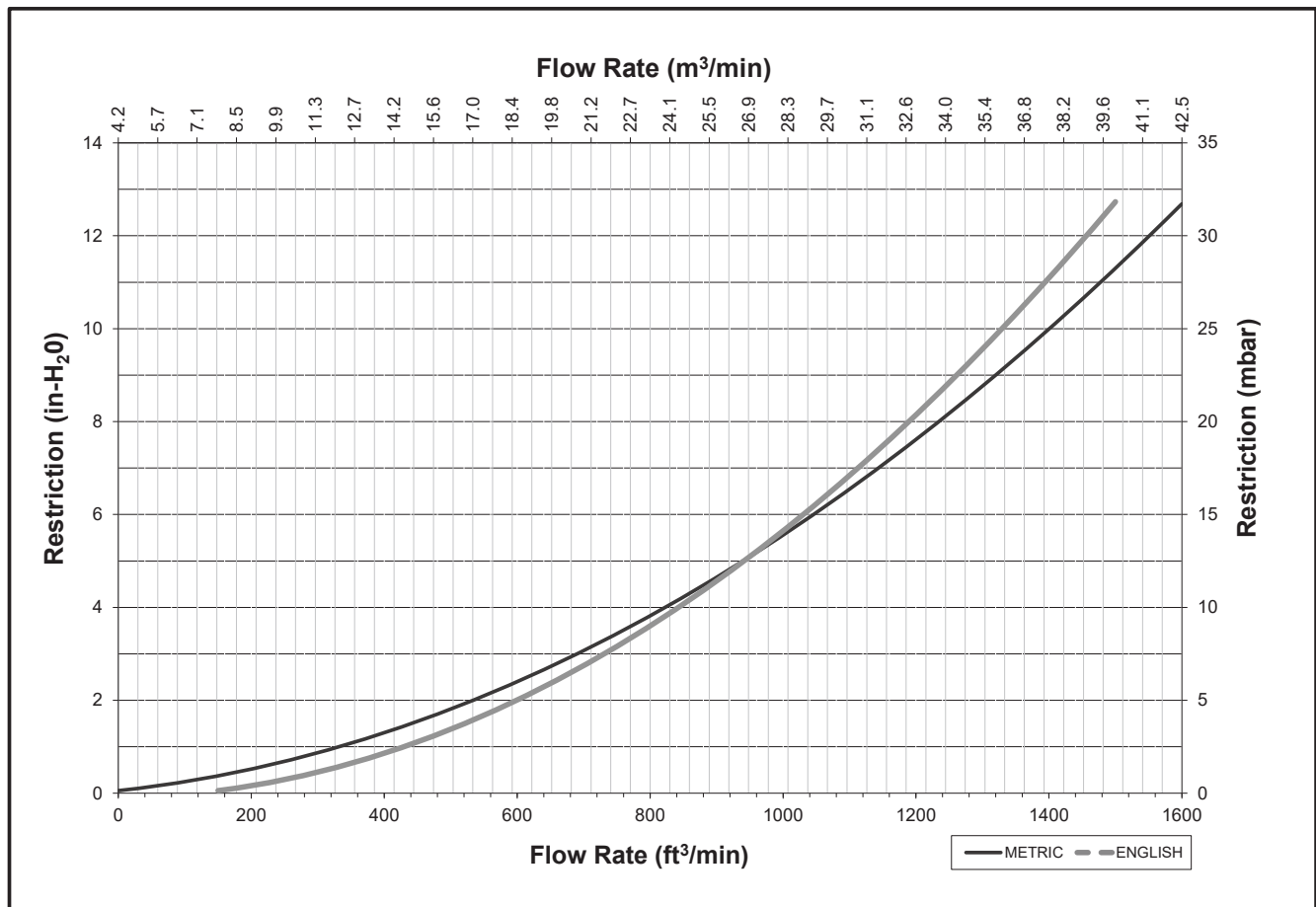

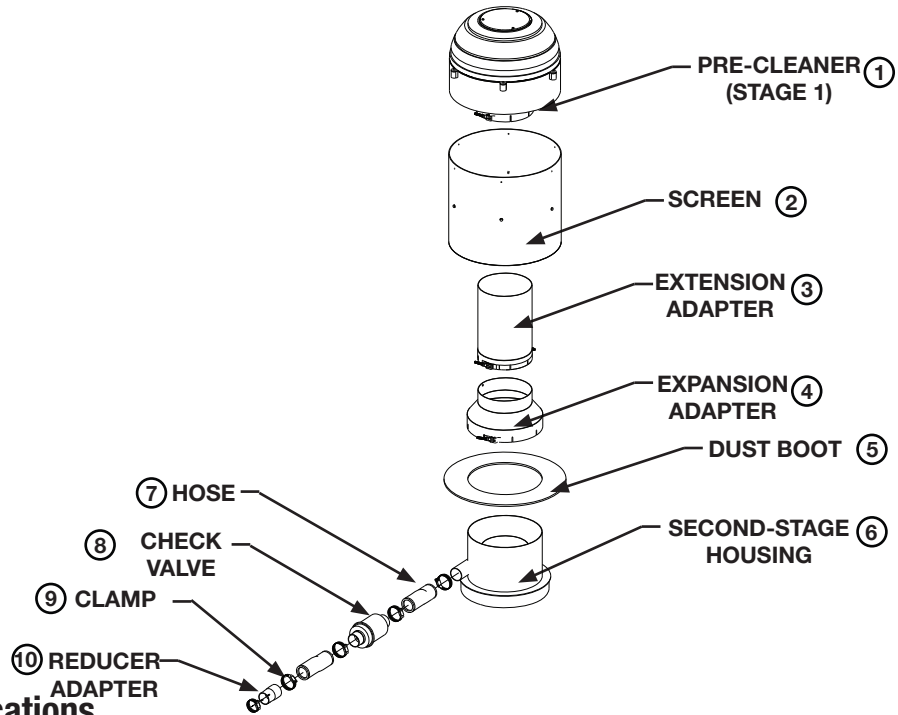

Specifications

Specification	AP85154
Width, Overall	16.6" (Ø 421.6 mm)
Height, Overall	38.0" (966.8 mm)
Application Flow Rate	800-1150 CFM (22.65-32.56 m ³ /min)
Outlet Tube	13.0" (Ø 330.2 mm)

Dimensions

Specifications subject to change without notice.

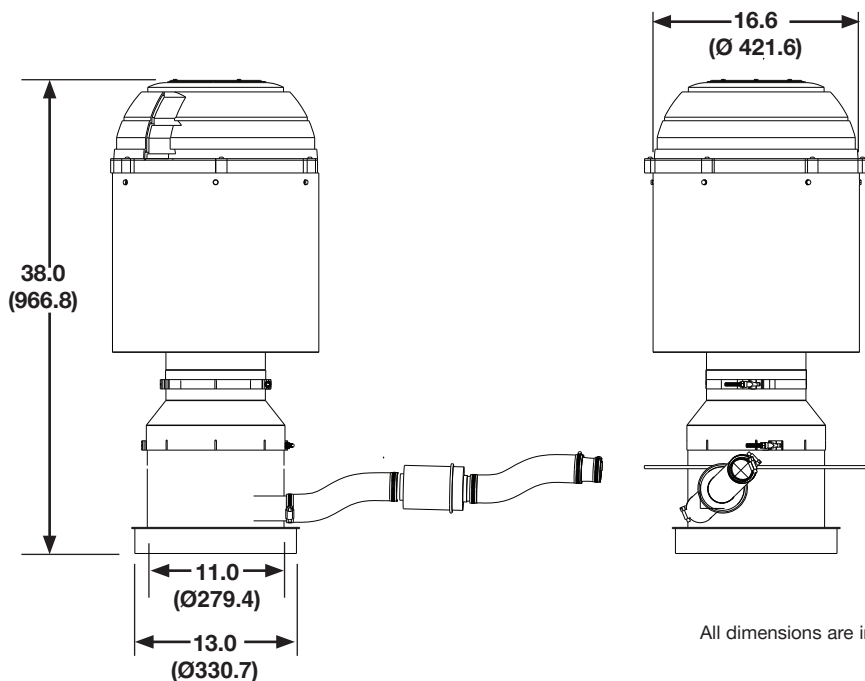

All dimensions are in inches (millimeters)

Ordering Information

Dual-Stage Pre-Cleaner	
Part Number	Description
AP85154	Dual-Stage Pre-Cleaner

Service Parts		
	Part Number	Description
①	AP8405	Pre-Cleaner
②	3946089S	Screen
③	3946105S	8" Extension Adapter
④	3918244S	8" to 11" Expansion Adapter
⑤	3953530S	Dust Boot
⑥	3953519S	Second-Stage Housing
⑦	3952359S	Hose
⑧	3953535S	Check Valve
⑨	3952353S	Clamp
⑩	3952334S	Reducer Adapter

Performance

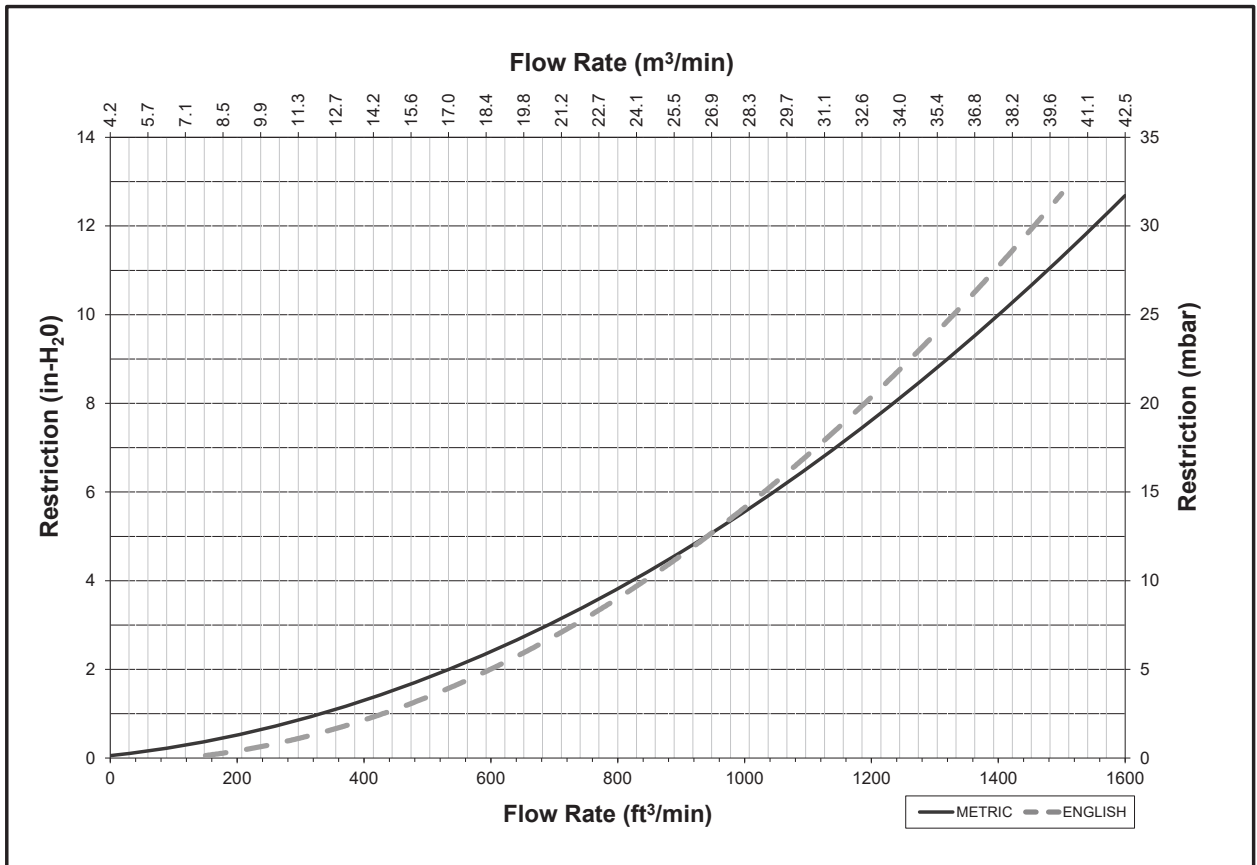

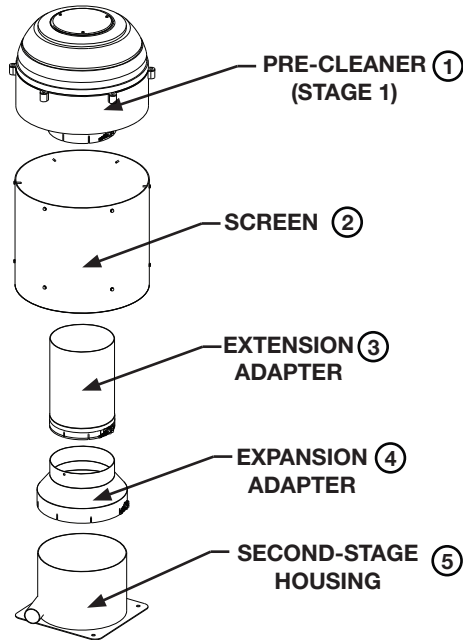

Specifications

Specification	AP85163
Width, Overall	16.6" (Ø 421.6 mm)
Height, Overall	37.5" (951.6 mm)
Application Flow Rate	1150-1400 CFM (32.56-39.64 m³/min)
Outlet Tube	7.0" (Ø 177.8 mm)

Dimensions

Mounting

Specifications subject to change without notice.

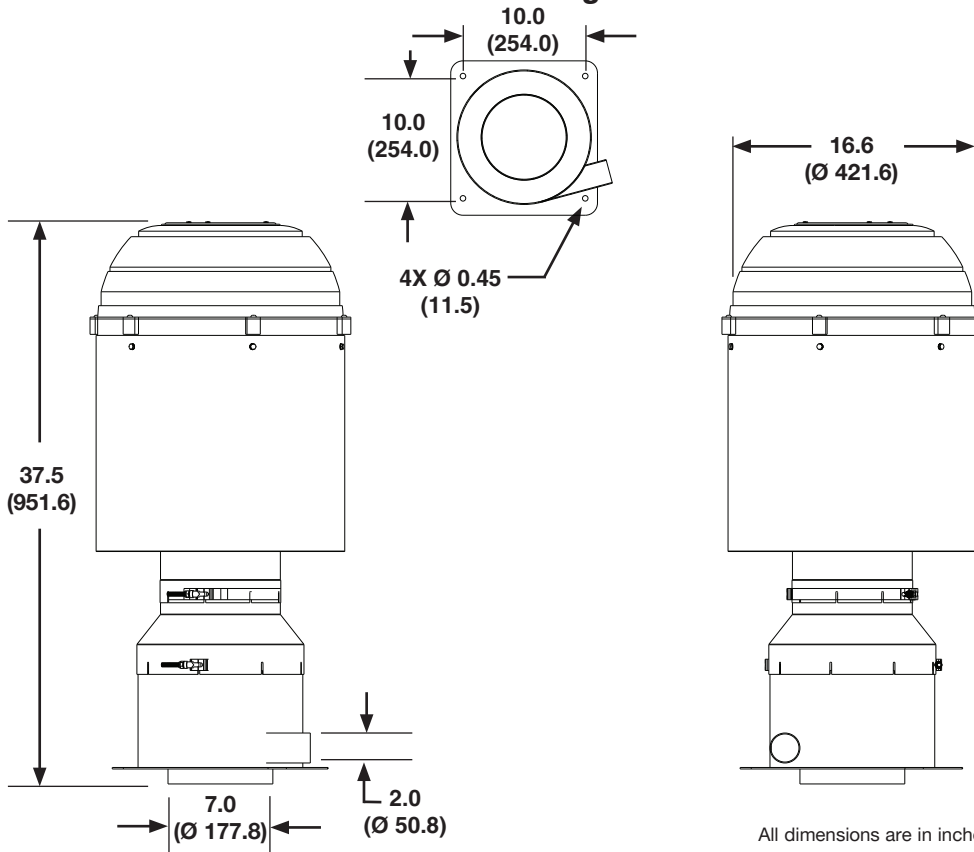

All dimensions are in inches (millimeters)

Ordering Information

Dual-Stage Pre-Cleaner	
Part Number	Description
AP85163	Dual-Stage Pre-Cleaner

Service Parts		
	Part Number	Description
①	AP8406	Pre-Cleaner
②	3946089S	Screen
③	3946105S	8" Extension Adapter
④	3918244S	8" to 11" Expansion Adapter
⑤	3953528S	Second-Stage Housing

Performance

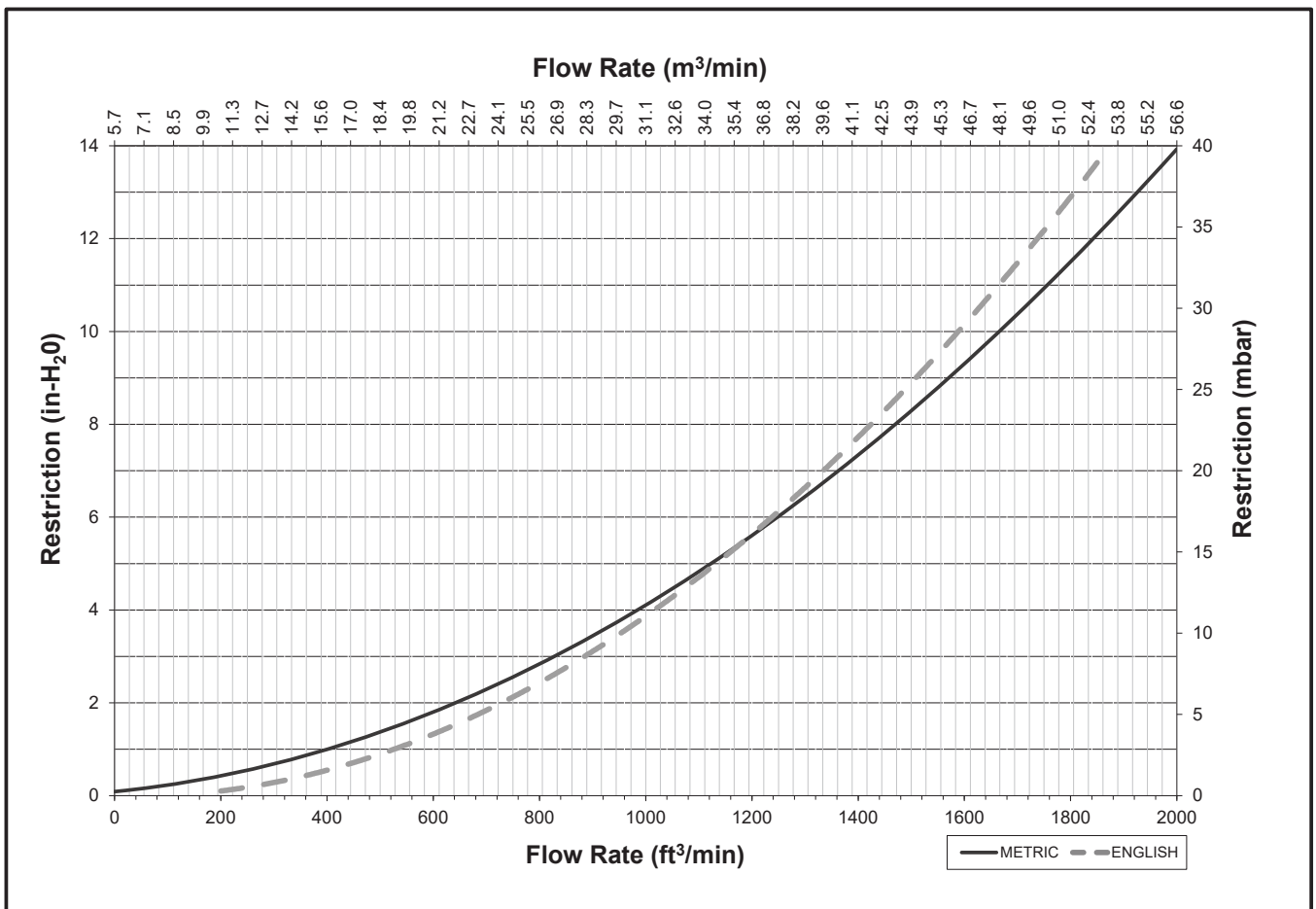

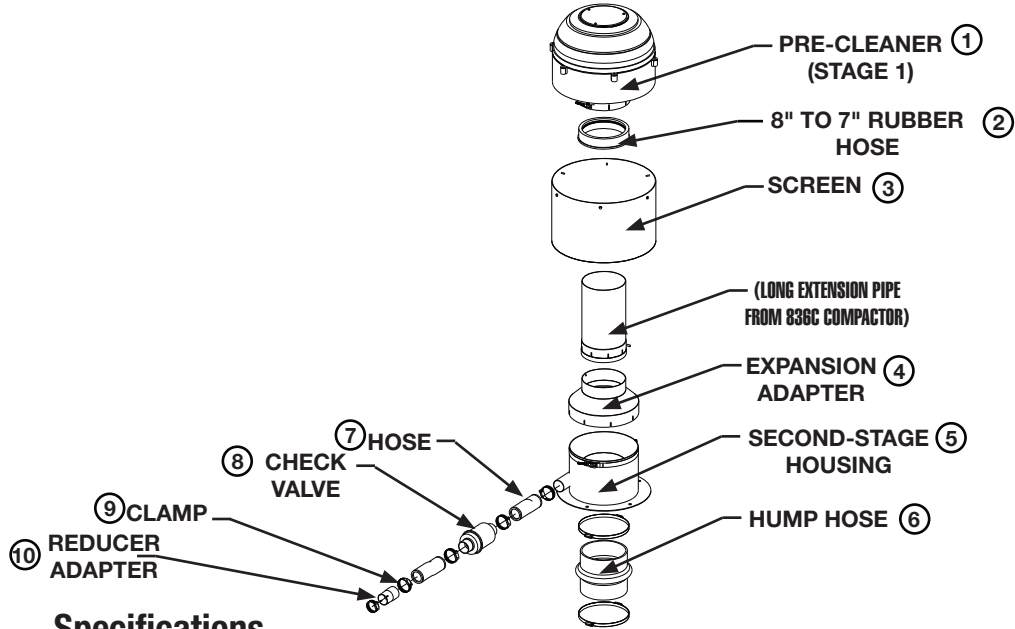

Specifications

Specification	AP85061
Width, Overall	16.6" (Ø 421.6 mm)
Height, Overall	37.8" (961.5 mm)
Application Flow Rate	1150-1400 CFM (32.56-39.64 m ³ /min)
Outlet Tube	7" (Ø 177.8 mm)

Dimensions

Specifications subject to change without notice.

Mounting

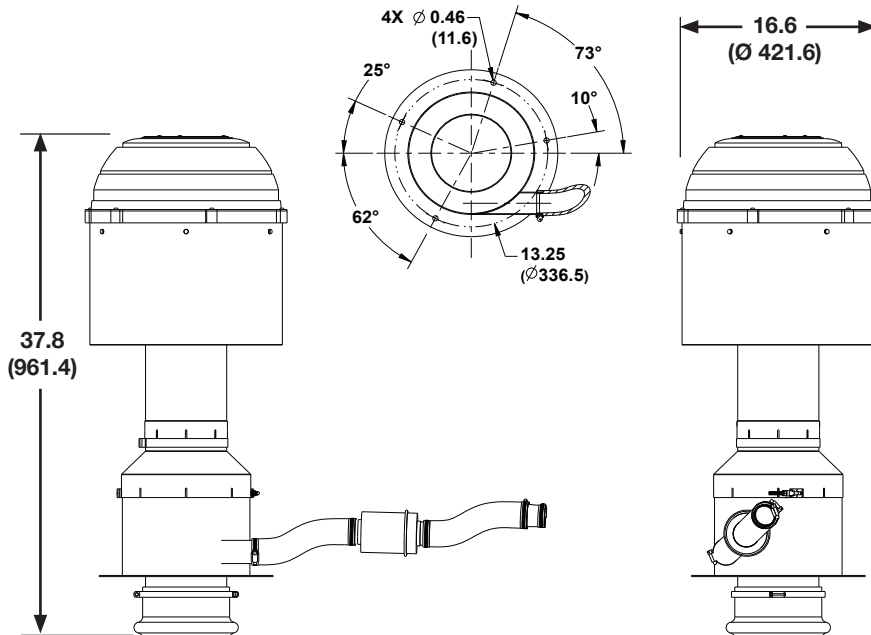

All dimensions are in inches (millimeters)

Ordering Information

Dual-Stage Pre-Cleaner	
Part Number	Description
AP85061	Dual-Stage Pre-Cleaner

Service Parts		
	Part Number	Description
①	AP8406	Pre-Cleaner
②	3918243S	8" to 7" Rubber Ring
③	3953544S	Screen
④	3952349S	8" to 11" Expansion Adapter
⑤	3953518S	Second-Stage Housing
⑥	3952359S	Hose
⑦	3952351S	Hump Hose
⑧	3953535S	Check Valve
⑨	3952353S	Clamp
⑩	3952334S	Reducer Adapter

Performance

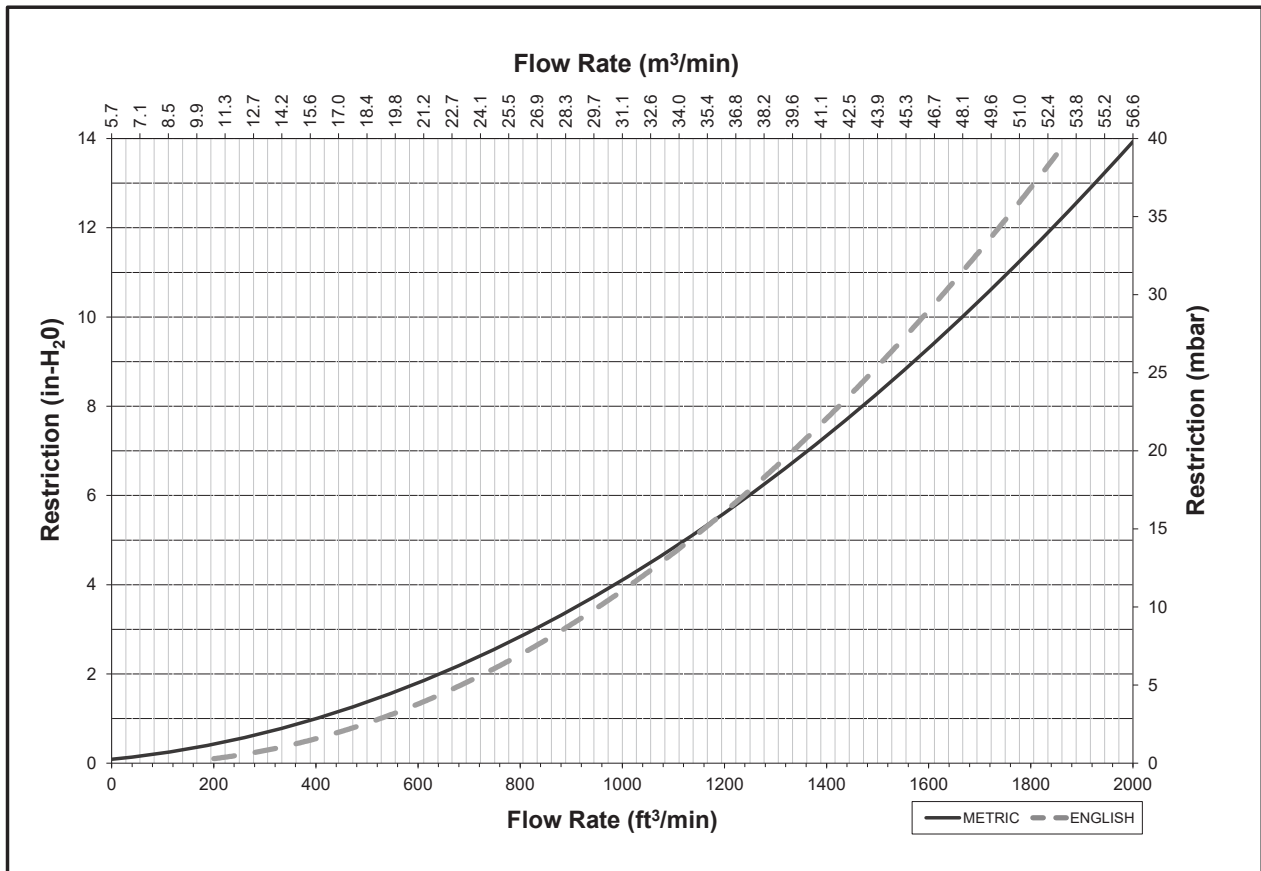

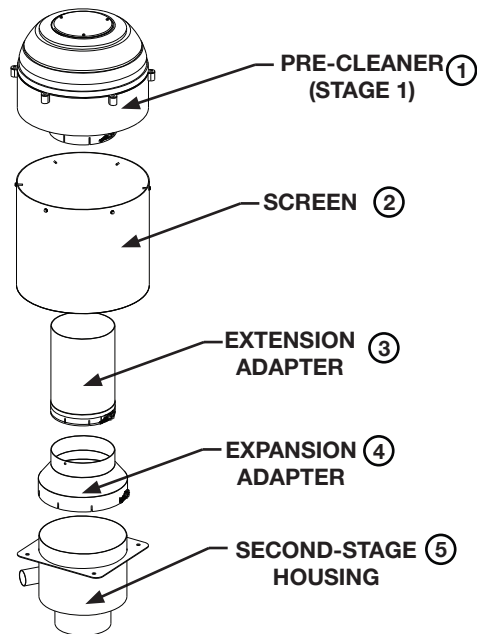

Specifications

Specification	AP85062
Width, Overall	16.6" (Ø 421.6 mm)
Height, Overall	40.8" (1037.0 mm)
Application Flow Rate	1150-1400 CFM (32.56-39.64 m³/min)
Outlet Tube	7" (Ø 177.8 mm)

Dimensions

Specifications subject to change without notice.

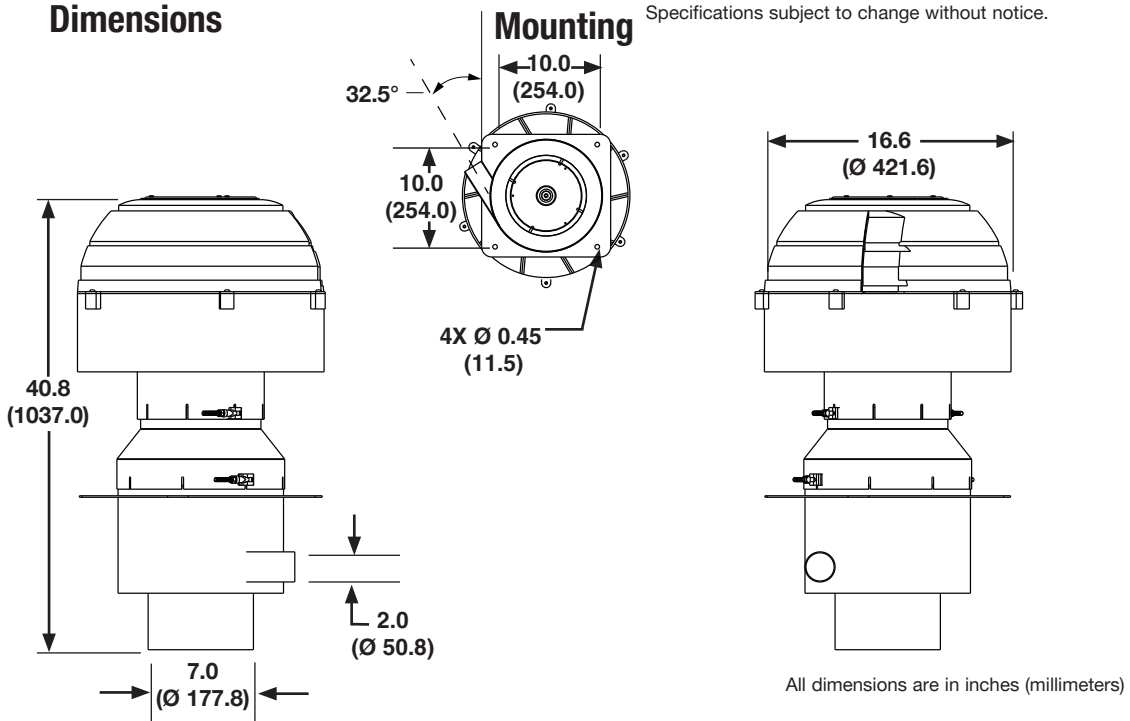

All dimensions are in inches (millimeters)

Ordering Information

Dual-Stage Pre-Cleaner	
Part Number	Description
AP85062	Dual-Stage Pre-Cleaner

Service Parts		
	Part Number	Description
①	AP8406	Pre-Cleaner
②	3946089S	Screen
③	3946105S	8" Extension Adapter
④	3918244S	8" to 11" Expansion Adapter
⑤	3953527S	Second-Stage Housing

Performance

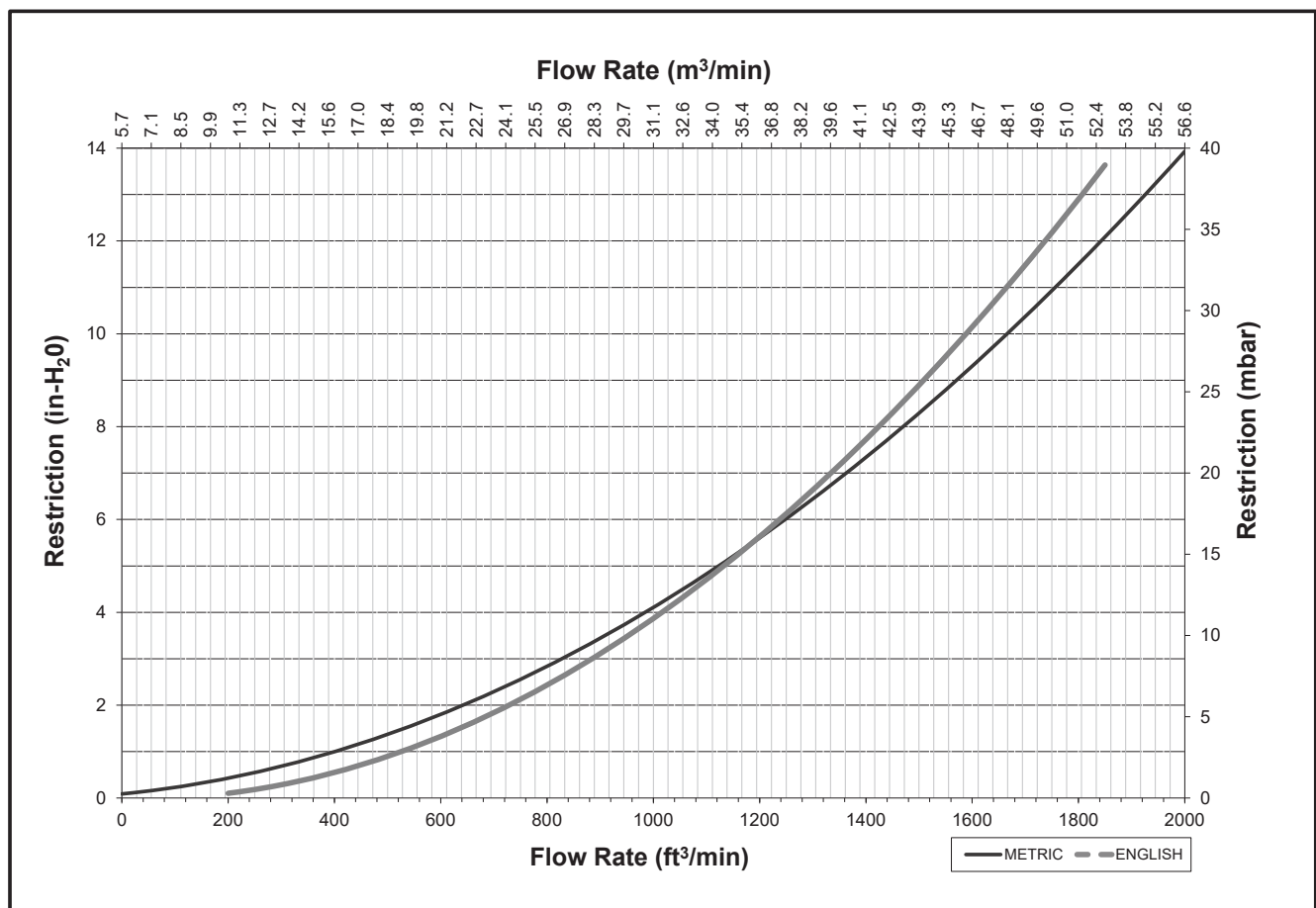

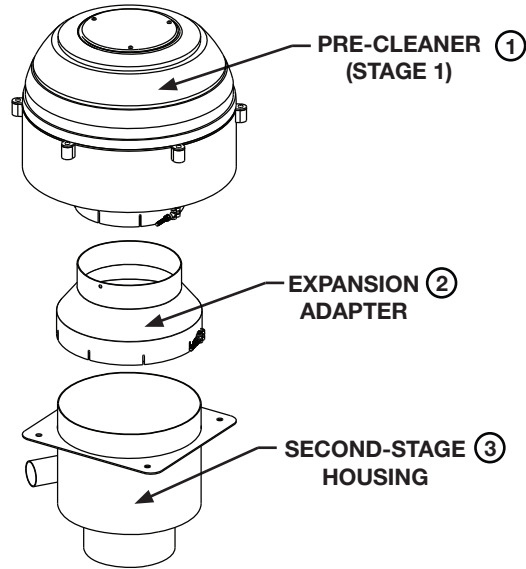

Specifications

Specification	AP85063
Width, Overall	16.4" (Ø 416.3 mm)
Height, Overall	29.9" (759.2 mm)
Application Flow Rate	1150-1400 CFM (32.56-39.64 m ³ /min)
Outlet Tube	7.0" (Ø 177.8 mm)

Dimensions

Specifications subject to change without notice.

Mounting

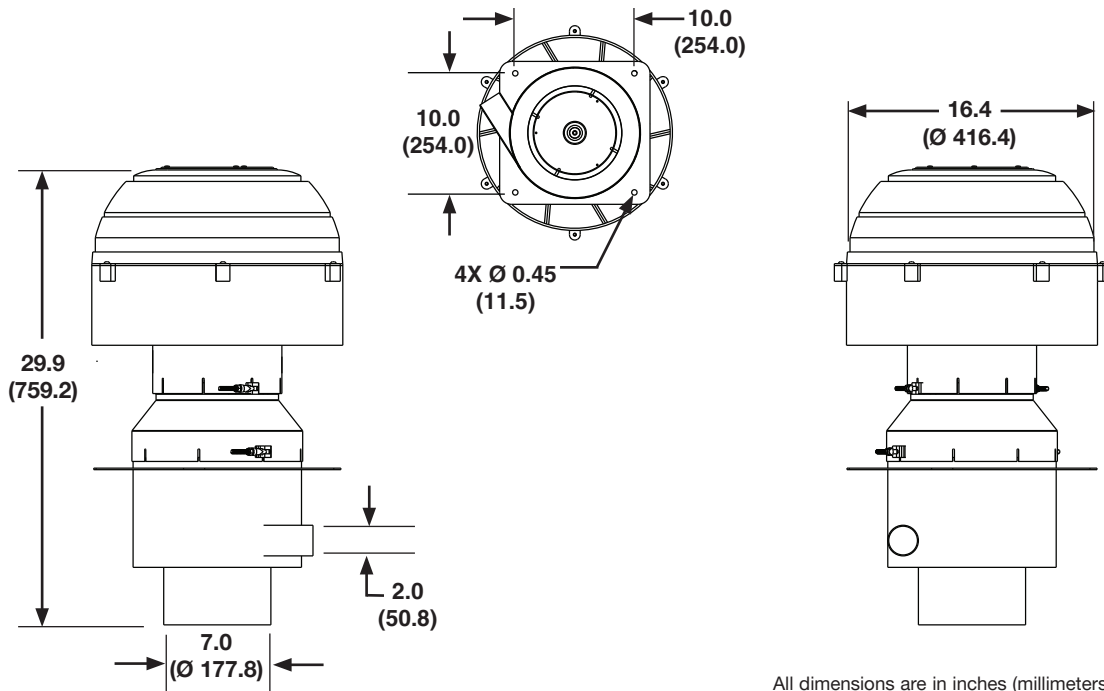

All dimensions are in inches (millimeters)

Ordering Information

Dual-Stage Pre-Cleaner	
Part Number	Description
AP85063	Dual-Stage Pre-Cleaner

Service Parts		
	Part Number	Description
①	AP8406	Pre-Cleaner
②	3918244S	8" to 11" Expansion Adapter
③	3953527S	Second-Stage Housing

Performance

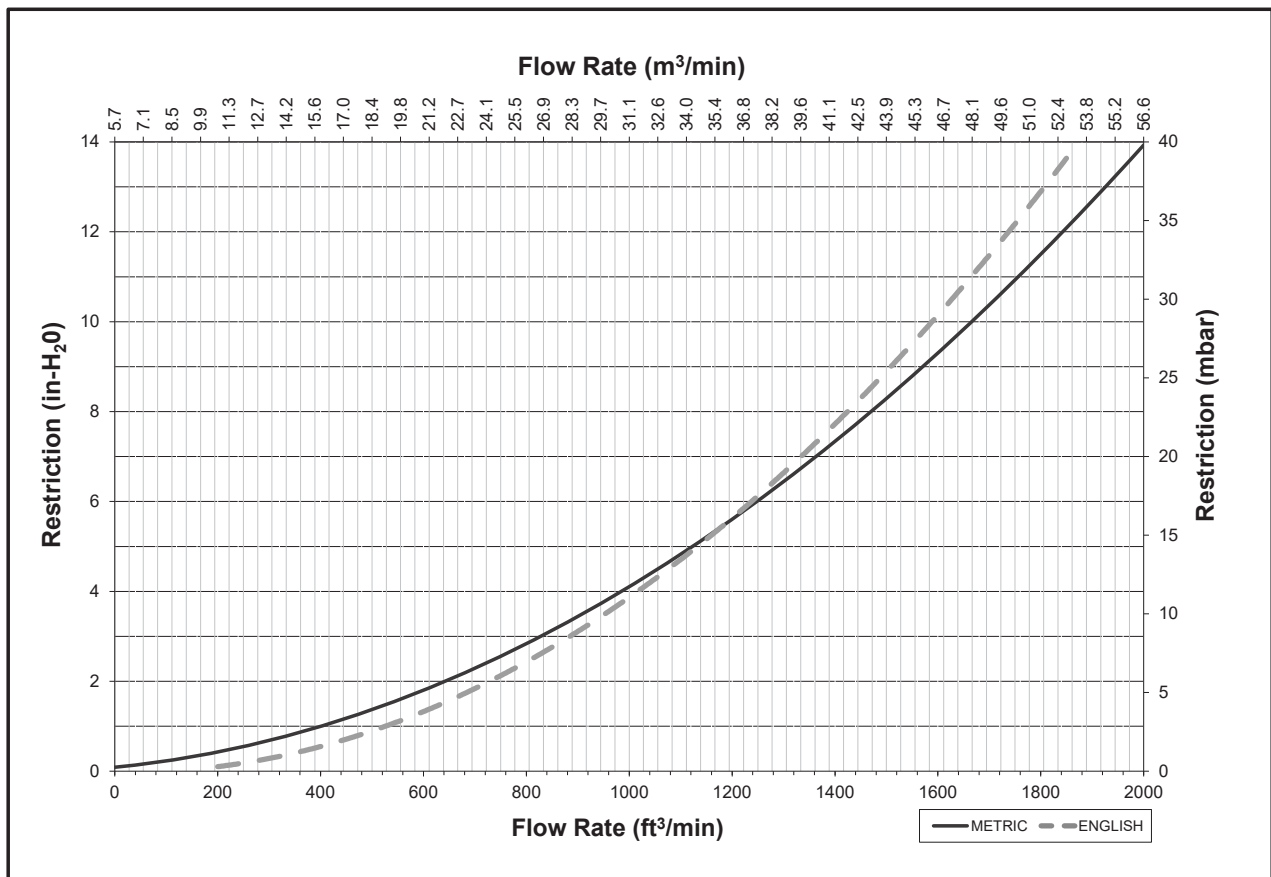

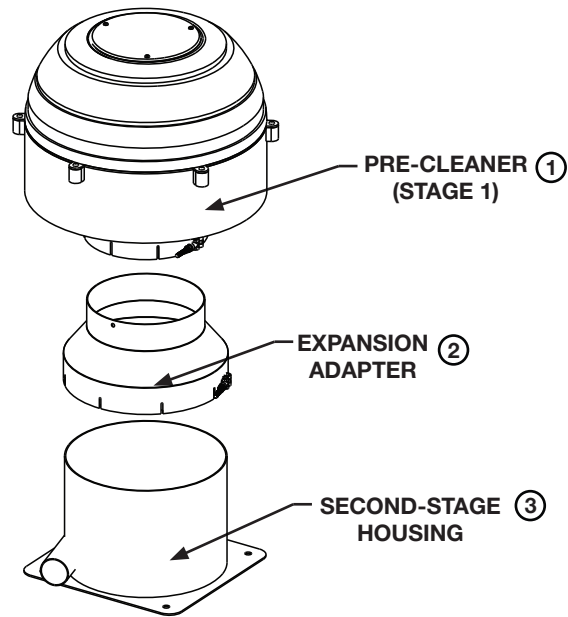

Specifications

Specification	AP85064
Width, Overall	16.4" (Ø 416.4 mm)
Height, Overall	26.7" (677.8 mm)
Application Flow Rate	1150-1400 CFM (32.56-39.64 m³/min)
Outlet Tube	7.0" (Ø 177.8 mm)

Specifications subject to change without notice.

Dimensions

Mounting

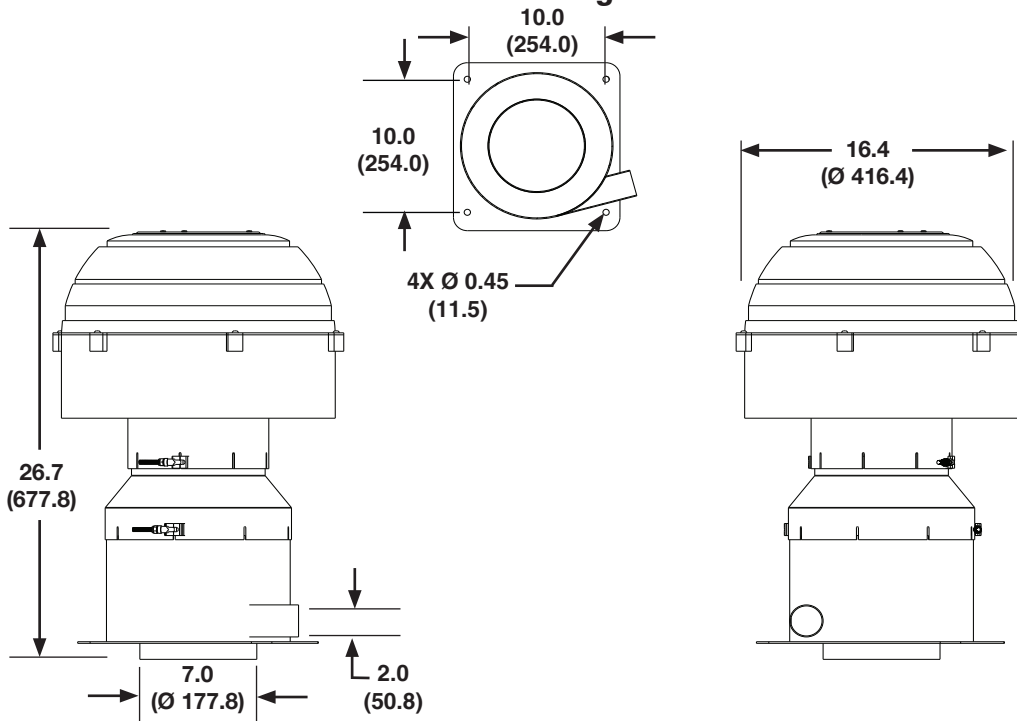

All dimensions are in inches (millimeters)

Ordering Information

Dual-Stage Pre-Cleaner	
Part Number	Description
AP85064	Dual-Stage Pre-Cleaner

Service Parts	
Part Number	Description
① AP8406	Pre-Cleaner
② 3918244S	8" to 11" Expansion Adapter
③ 3953528S	Second-Stage Housing

Performance

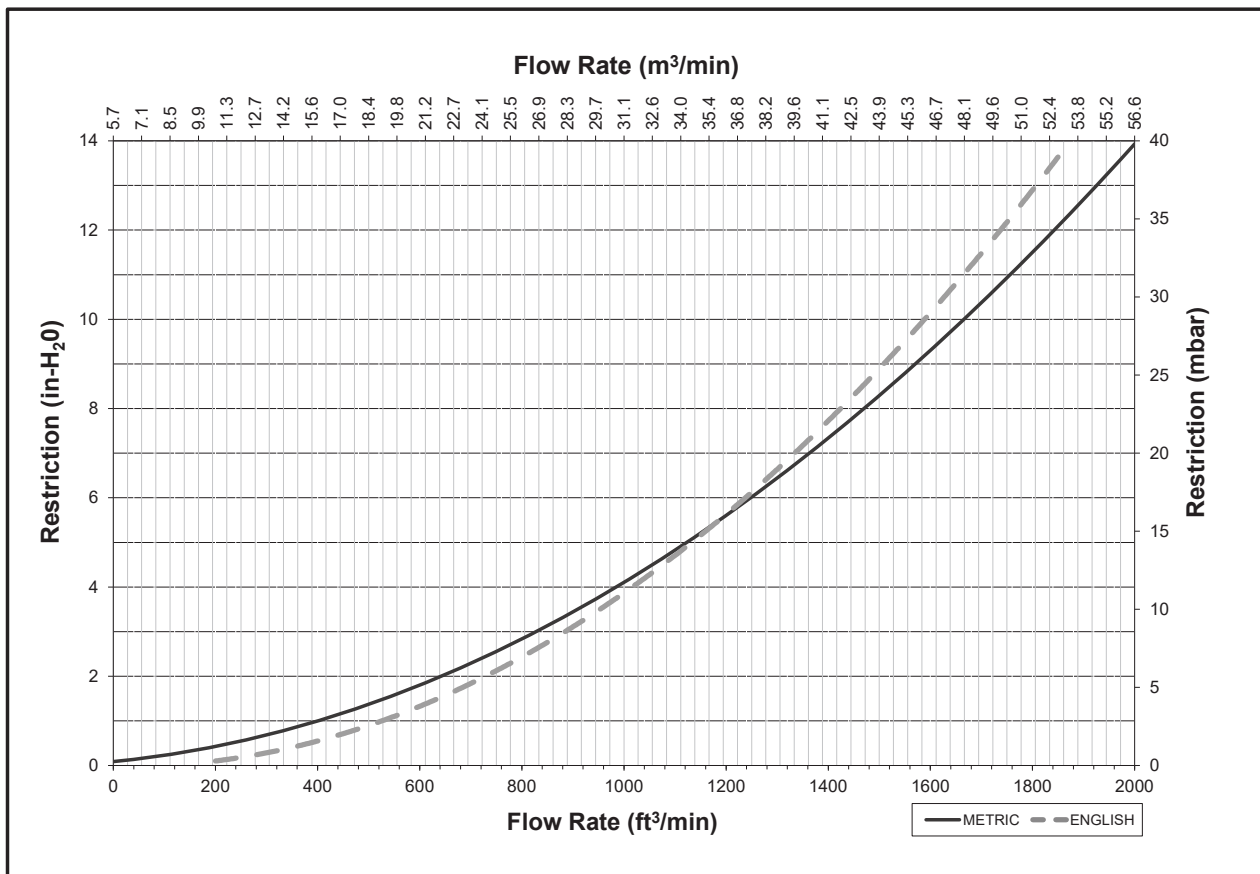

Radial Fin Pre-Cleaners



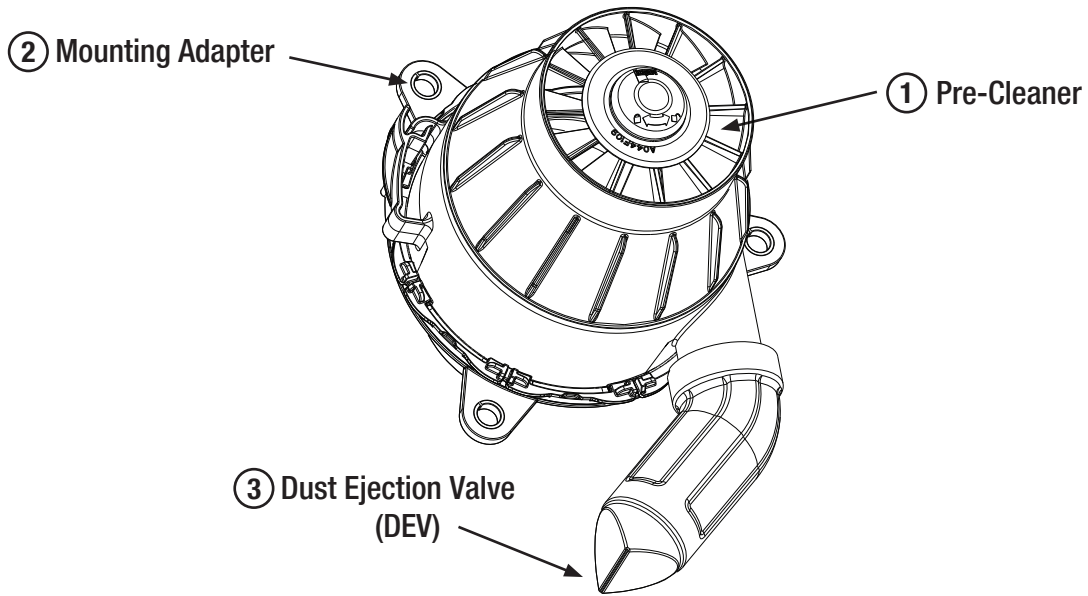

Specification	AP15910 & AP15911
Height, Overall	8.1" (206.5 mm)
Application Flow Rate	75-240 CFM (2.12-6.79 m ³ /min)
Outlet	4.0" (Ø 101.6 mm O.D.)

Specifications subject to change without notice.

Dimensions

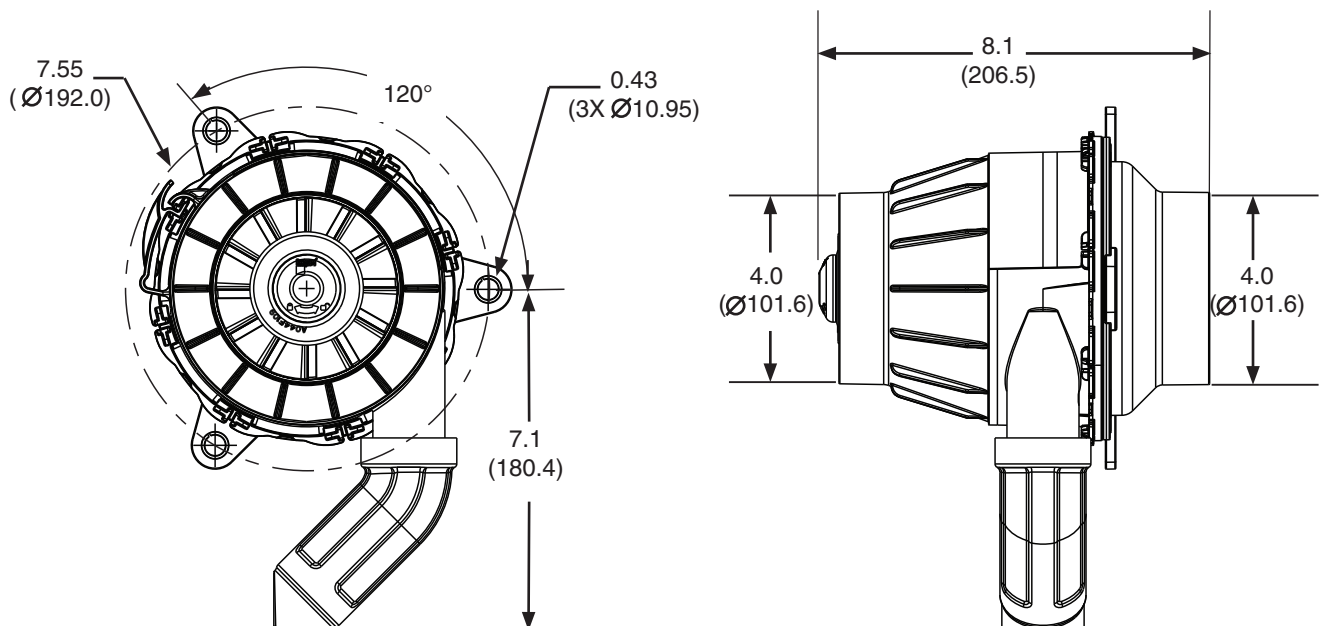

Ordering Information

Radial Fin Pre-Cleaner		
Part Number	Description	
① AP15910	Radial Fin Pre-Cleaner with Dust Ejection Valve	
② AP15911	Mounting Adapter	
③ SP1048	Dust Ejection Valve (DEV)	

Performance

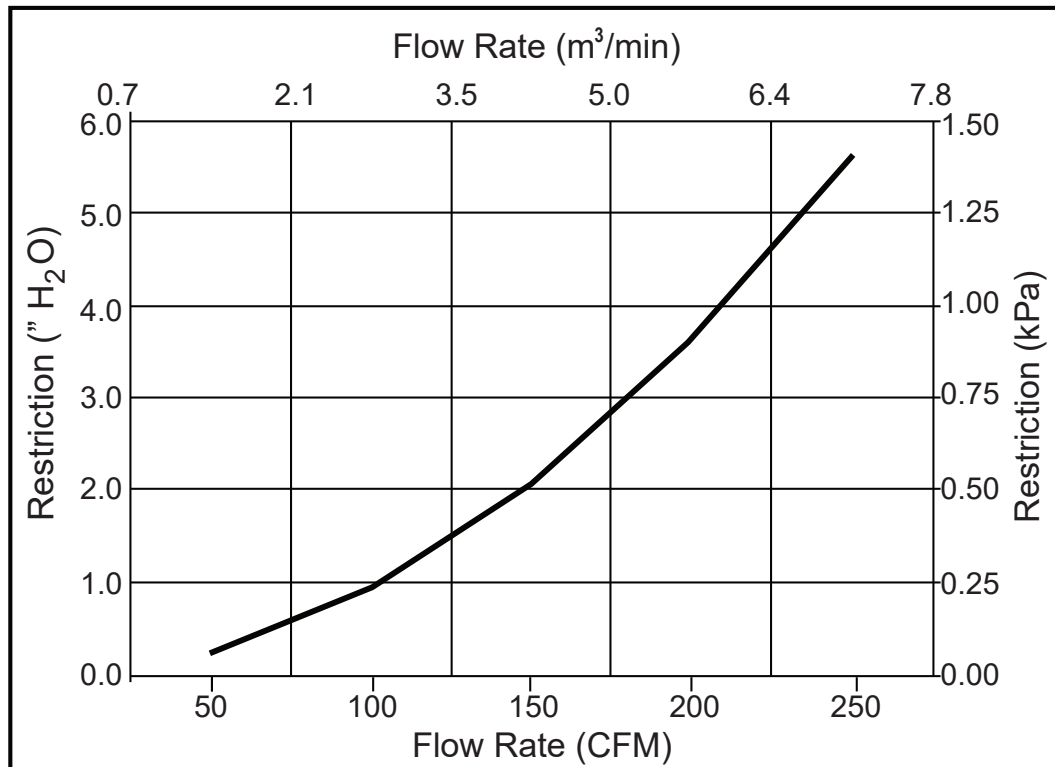

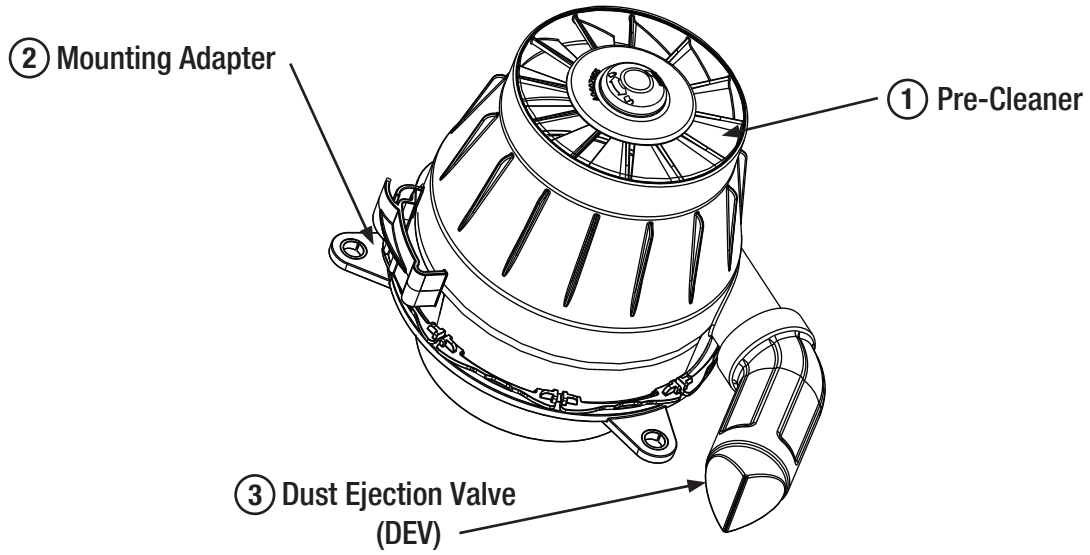

Specification	AP15914 & AP15912
Height, Overall	8.3" (210.8 mm)
Application Flow Rate	200-380 CFM (5.66-10.76 m ³ /min)
Outlet	5.0" (Ø 127.0 mm O.D.)

Specifications subject to change without notice.

Dimensions

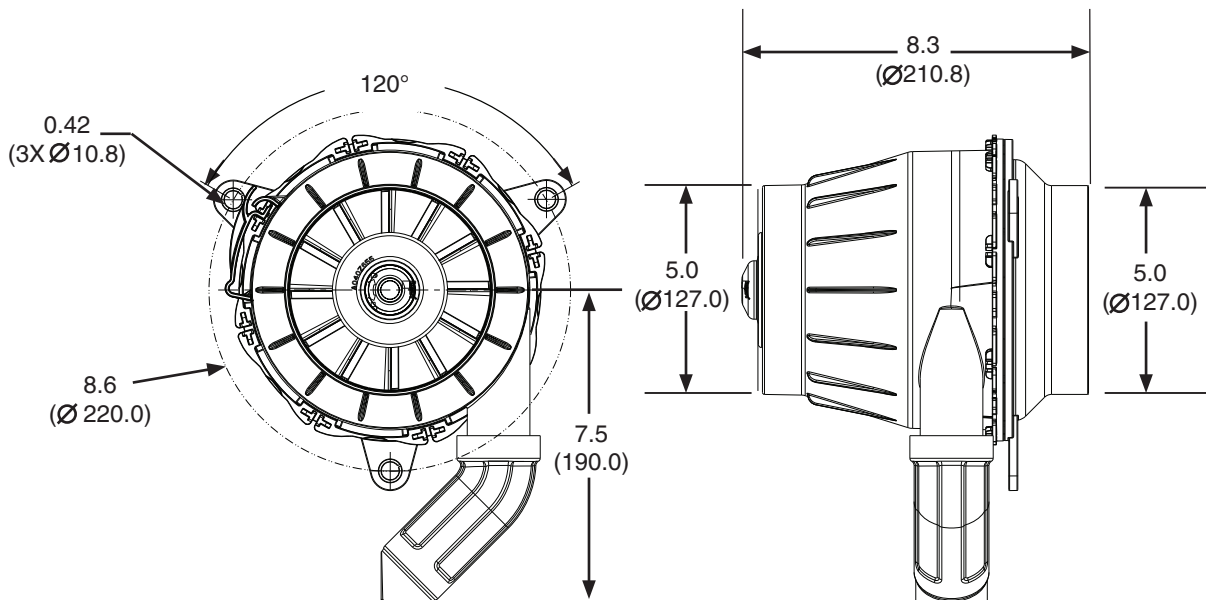

Ordering Information

Radial Fin Pre-Cleaner		
Part Number	Description	
① AP15914	Radial Fin Pre-Cleaner with Dust Ejection Valve	
② AP15912	Outlet Adapter	
③ SP1048	Dust Ejection Valve (DEV)	

Performance

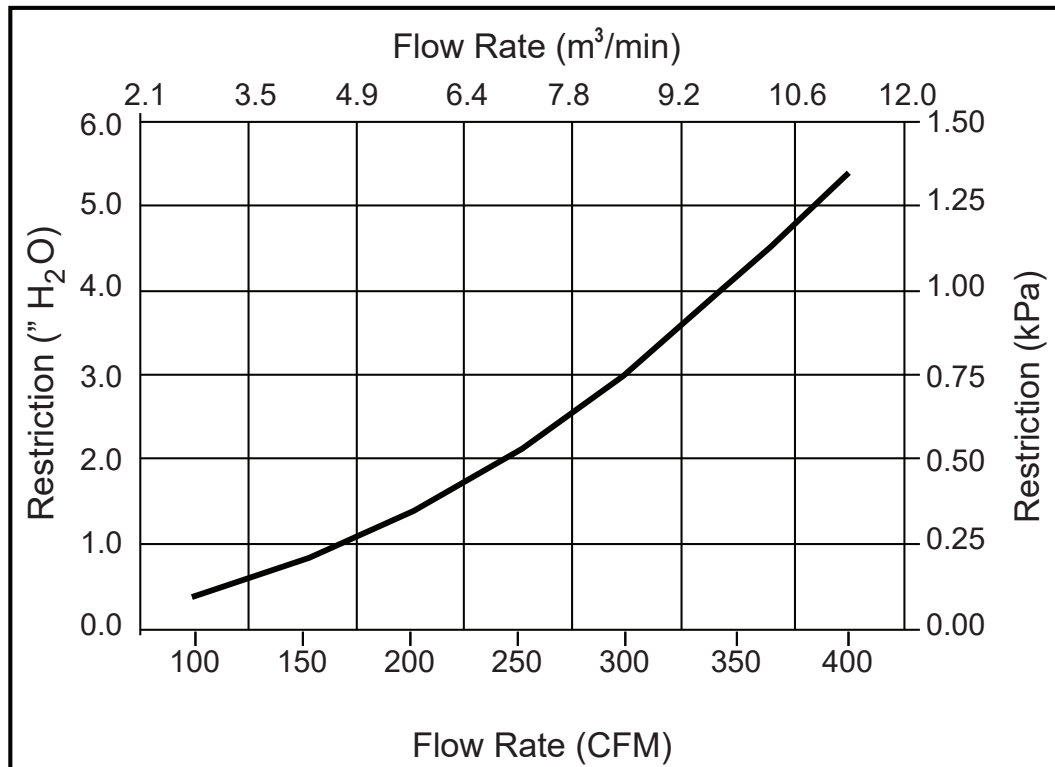

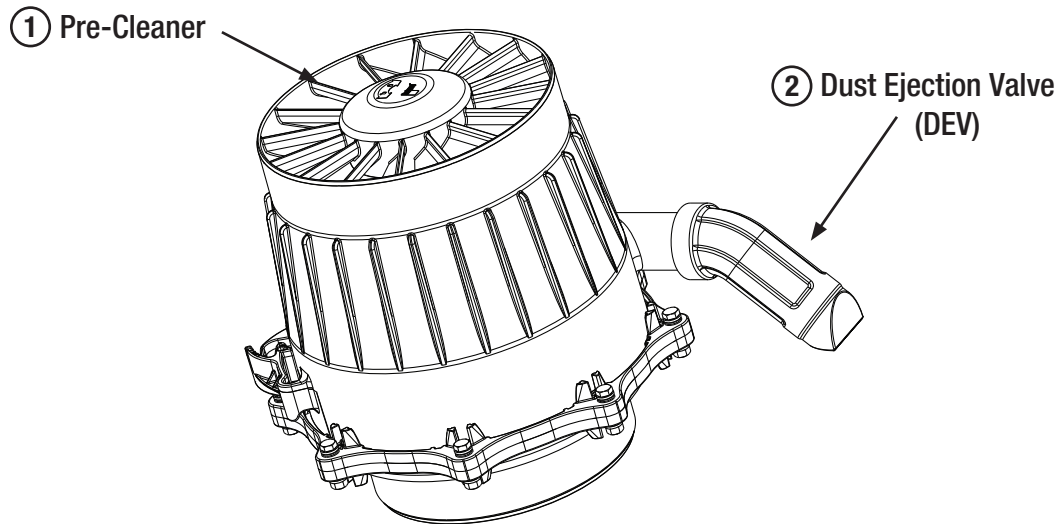

Specification	AP15918
Height, Overall	11.1" (282.0 mm)
Application Flow Rate	550-950 CFM (15.57-26.90 m ³ /min)
Outlet	7.0" (Ø 178.5 mm O.D.)

Specifications subject to change without notice.

Dimensions

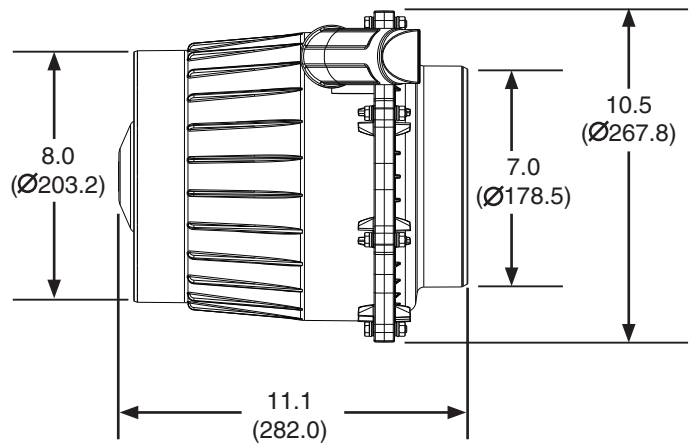
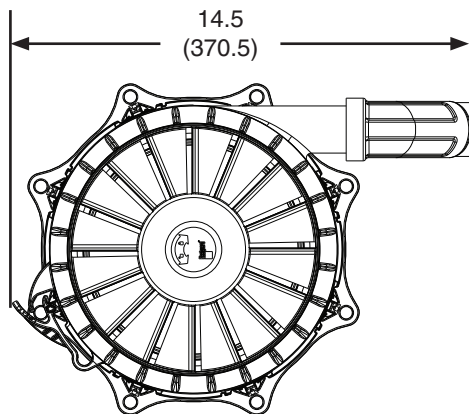

Ordering Information

Radial Fin Pre-Cleaner	
Part Number	Description
① AP15918	Radial Fin Pre-Cleaner with Outlet Adapter & Dust Ejection Valve
② SP1048	Dust Ejection Valve (DEV)

Performance

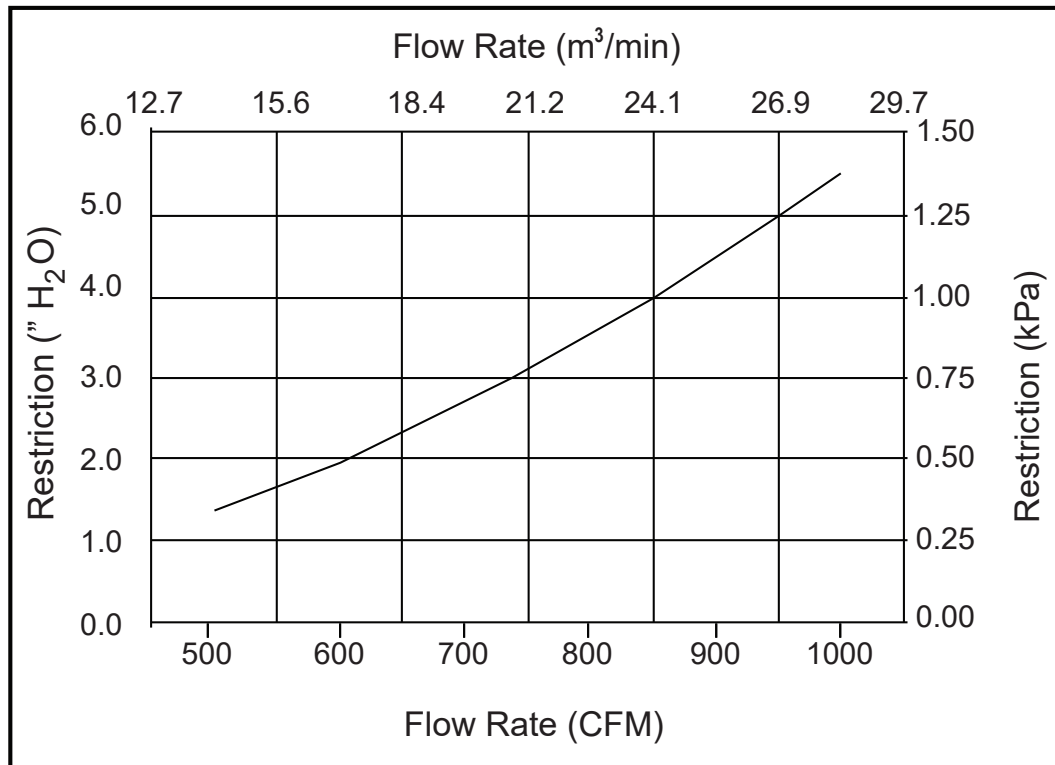

Installation Kits*

Part Number	Size in (mm)	Adapts to Intake Size	
		in	mm
3918240 S	3 (76.2)	2/2.5/2.75	50.8/63.5/69.85
3904837 S	4 (101.6)	3/3.5/3.75	76.2/88.9/95.25
3904838 S	4 (101.6)	4/4.5/4.75/5	101.6/114.3/120.65/127.0
3904839 S	4 (101.6)	5.25/5.5/6	133.35/139.7/152.4
3946050 S	6 (152.4)	4	101.6
3946051 S	6 (152.4)	4/5	101.6/127.0
3904840 S	6 (152.4)	5/5.25/5.5	127.0/133.35/139.7
3904841 S	6 (152.4)	6.25/6.5/7	158.75/165.1/177.8
3905073 S	6 (152.4)	9	228.6
3946055 S	6 (152.4)	7/10/11	177.8/254.0/279.4
3946053 S	6 (152.4)	5	127.0
3946056 S	8 (203.2)	6/7	152.4/177.8
3904842 S	8 (203.2)	7/9	177.8/228.6
3905074 S	8 (203.2)	10/11	254.0/279.4
3946057 S	8 (203.2)	6/7	152.4/177.8
3946058 S	8 (203.2)	Special Kit	

* Installation Kits do not contain pre-cleaners, only the necessary adapters for installing a pre-cleaner to the matched intake sizes.

Rubber Reducing Adapters

Use when your pre-cleaner is larger than your air intake pipe.

Part Number	From in (mm)	To in (mm)
3939406 S	2 (50.8)	1.75 (44.45)
3939404 S	3 (76.2)	2.5 (63.5)
3939403 S	3 (76.2)	2.75 (69.85)
3946102 S	4 (101.6)	2.5 (63.5)
3946101 S	4 (101.6)	2.75 (69.85)
3946100 S	4 (101.6)	3 (76.2)
3946099 S	4 (101.6)	3.75 (95.25)
3939396 S	4 (101.6)	3.23 (82.04)
3946097 S	5 (127.0)	4 (101.6)

Part Number	From in (mm)	To in (mm)
3939399 S	5 (127.0)	4.5 (114.3)
3918245 S	6 (152.4)	5 (127.0)
3939401 S	6 (152.4)	5.25 (133.35)
3946095 S	7 (177.8)	6 (152.4)
3946094 S	7 (177.8)	6.25 (158.75)
3946093 S	7 (177.8)	6.5 (165.1)
3918243 S	8 (203.2)	7 (177.8)
3946088 S	9 (228.6)	8 (203.2)
3946104 S	11 (279.4)	10 (254.0)
3946103 S	13 (330.2)	12 (304.8)

Metal Expansion Adapters

Use when your pre-cleaner is smaller than your intake. Metal Expansion Adapters are spun metal, designed to withstand the elements.

Part Number	From in (mm)	To in (mm)
3920523 S	4 (101.6)	5 (127.0)
3946110 S	4 (101.6)	6 (152.4)
3918242 S	6 (152.4)	7 (177.8)
3905073 S	6 (152.4)	9 (228.6)
3946109 S	7 (177.8)	9 (228.6)
3946108 S	8 (203.2)	13 (330.2)
3946106 S	8 (203.2)	16 (406.4)

Basket/Mesh Screens

Use when operating in an environment with large debris (forestry, agriculture, landfill) to keep your pre-cleaner working at peak efficiency.

Part Number	Description	Pre-Cleaner Size in (mm)
3946112 S	Perforated Screen Kit	4 (101.6)
3946091 S	Perforated Screen Replacement	4 (101.6)
3946090 S	Perforated Screen Replacement	6 (152.4)
3946089 S	Perforated Screen Replacement	8 (203.2)

Metal Extension Pipes

Use when your pre-cleaner is below the hood line or you need more hood clearance underneath the pre-cleaner.

Part Number	A Diameter in (mm)	B Length in (mm)
3939409 S	4 (101.6)	12 (304.8)
3939410 S	5 (127.0)	12 (304.8)
3939411 S	6 (152.4)	12 (304.8)
3946107 S	7 (177.8)	14 (355.6)
3946105 S	8 (203.2)	12 (304.8)

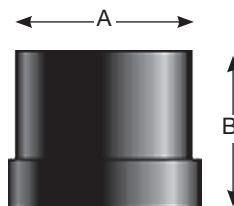

Rubber Expansion Adapters

Use when your pre-cleaner is smaller than your intake. Rubber Expansion Adapters are rubber pieces, designed to withstand the elements.

Part Number	From in (mm)	To in (mm)
3946098 S	4.25 (107.95)	4.5 (114.3)
3946092 S	6.25 (158.75)	7 (177.8)

Dust Ejection Valve Plugs

Use to seal the dump valve portion of an internal or dust ejector pre-cleaner when the dump valve is removed.

Part Number	Size in (mm)
3939409 S	4 (101.6)
3939410 S	5 (127.0)
3939411 S	6 (152.4)
3946107 S	7 (177.8)
3946105 S	8 (203.2)



Aspiration System

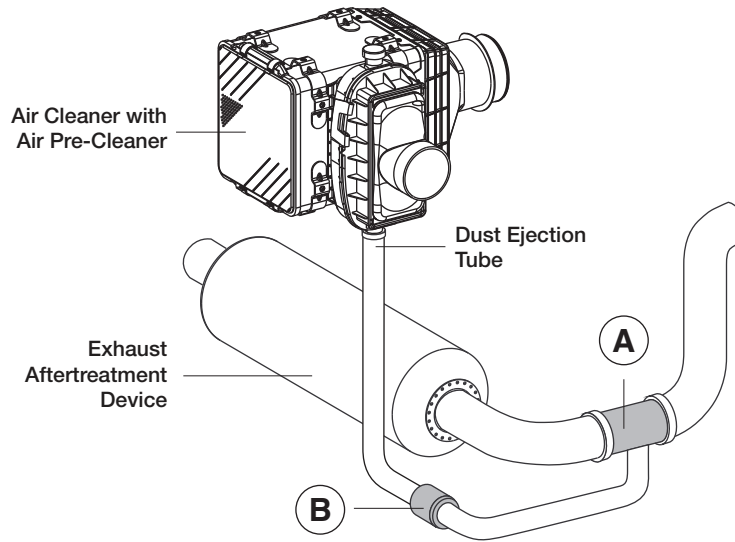

Aspirator Specifications

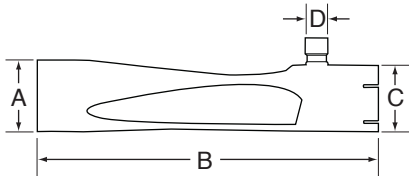

Engine Air Flow CFM (m ³ /min)	A and C Inlet/Outlet Diameter in (mm)	B Length in (mm)	D Aspirator Tube Diameter in (mm)
14-21 (500-740)	5.03 (127.8)	22.00 (558.8)	1.50 (38)
660-950 (19-27)	5.03 (127.8)	22.00 (558.8)	1.75 (44)
800-1150 (23-33)	6.04 (153.4)	24.00 (609.6)	2.00 (51)
950-1350 (27-38)	6.04 (153.4)	24.00 (609.6)	2.00 (51)

Check Valve Specifications

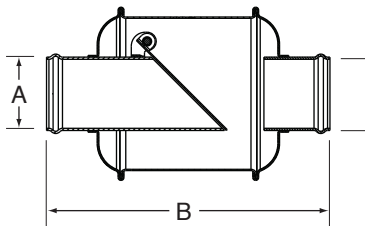

Representation only.
May not reflect actual check valve.

A and C Inlet/Outlet Diameter in (mm)	B Length in (mm)	Shell Diameter in (mm)	Part Number
2 (5.08)	4.45 (113)	2.78 (70.5)	SP01025
1.5 (38.1)	4.45 (113)	2.78 (70.5)	SP01263

Ordering Information

Typical Engine Size Range	General Engine Description	Typical Engine Intake Air Flow CFM (m3/min)	Exhaust Aspirator Inlet Diameter in (mm)	Exhaust Aspirator Length in (mm)	Typical Exhaust Diameter in (mm)	Typical Engine Exhaust Flow CFM @ 900 °F (m3/min @ 482 °C)	Check Valve Diameter in (mm)	Part Number		
								A Aspirator	B Aspiration Check Valve	C Optional Exhaust Adapter
6L-7L	Mid-Range	500 (14.2)	5 (127)	22 (559)	4 (102)	1259 (36)	1.5 (38)	SP1267	SP1375	SP1281
		600 (17.0)	5 (127)	22 (559)	4 (102)	1511 (43)	1.5 (38)	SP1267	SP1375	SP1281
7L-10L	Mid-Range	500 (14.2)	5 (127)	22 (559)	4 (102)	1259 (36)	1.5 (38)	SP1267	SP1375	SP1281
		600 (17.0)	5 (127)	22 (559)	4 (102)	1511 (43)	1.5 (38)	SP1267	SP1375	SP1281
		700 (19.8)	5 (127)	22 (559)	4 (102)	1763 (50)	1.5 (38)	SP1267	SP1375	SP1281
10L-13L	Heavy Duty	600 (17.0)	5 (127)	22 (559)	5 (127)	1511 (43)	1.5 (38)	SP1267	SP1375	N/A
		700 (19.8)	5 (127)	22 (559)	5 (127)	1763 (50)	1.5 (38)	SP1267	SP1375	N/A
		800 (22.7)	5 (127)	22 (559)	5 (127)	2015 (57)	2 (51)	SP1266	SP1376	N/A
		900 (25.5)	5 (127)	22 (559)	5 (127)	2267 (64)	2 (51)	SP1266	SP1376	N/A
		1000 (28.3)	6 (152)	24 (610)	5 (127)	2519 (71)	2 (51)	SP1265	SP1376	SP1282
		1100 (31.2)	6 (152)	24 (610)	5 (127)	2770 (78)	2 (51)	SP1264	SP1376	SP1282
13L-15L	Heavy Duty	800 (22.7)	5 (127)	22 (559)	5 (127)	2015 (57)	2 (51)	SP1266	SP1376	N/A
		900 (25.5)	5 (127)	22 (559)	5 (127)	2267 (64)	2 (51)	SP1266	SP1376	N/A
		1000 (28.3)	6 (152)	24 (610)	5 (127)	2519 (71)	2 (51)	SP1265	SP1376	SP1282
		1100 (31.2)	6 (152)	24 (610)	5 (127)	2770 (78)	2 (51)	SP1265	SP1376	SP1282
		1200 (34.0)	6 (152)	24 (610)	5 (127)	3022 (86)	2 (51)	SP1264	SP1376	SP1282
		1300 (36.8)	6 (152)	24 (610)	5 (127)	3274 (93)	2 (51)	SP1264	SP1376	SP1282

Should I change my air filter element on a distance, time, appearance, or weight basis?

Air filters should be changed according to the engine manufacturer's recommendation on air flow restriction as measured by an air filter restriction indicator gauge.

Does the efficiency of an air filter element change while it is being used?

Yes, air filter element efficiency changes over time. Air filter elements are least efficient when they are new. The build up of contaminant (dirt) on the medium will make it more efficient over time.

What is the difference between the Fleetguard® Magnum RS™ and the Standard line of air filters?

Magnum air filters have a larger surface area of filter medium and will therefore hold more contaminant, resulting in a longer service life.

What is the meaning of the "M" suffix used on some air filter part numbers?

The 'M' stands for Magnum, designating it as a long life element.

How often should I change my secondary air filter element?

Secondary or inner elements should be changed every third time the primary (main/outer) element is changed. The secondary (safety/inner) element should not be disturbed until this interval has been reached.

What is your recommended air filter element change interval?

We recommend changing Fleetguard air filter elements when they have reached about 80% of the engine manufacturer's maximum allowable restriction. As a general guide, this ranges from 375 to 500 mm (15 to 20") of water gauge restriction for naturally aspirated engines and 500 to 700 mm (20 to 30") for turbocharged engines.

What is the micron rating of Fleetguard air filter elements?

The performance of air filter elements is measured by testing their ability to remove particles across a broad spectrum of particle sizes using standard test dust and reporting the results as the percent efficiency for the given test dust.

How much should I tighten the clamps on the outlet tube connections?

The maximum clamp torque is 40 in-lb (4.5 N-m) on the outlet.

What is the meaning of the "K" suffix used on some air filter part numbers?

The "K" denotes that the filter is equipped with fins. The fins provide pre-cleaning by centrifuging out much of the contaminant before it reaches the air filter element. These elements are generally used in off-highway equipment (agriculture, construction, mining, etc.).

Conventional air filter elements are generally held in place inside the air cleaner housing by a wing nut on a threaded center post. This also seals the element to the housing by compressing a rubber seal (gasket), which is glued to the metal endplate of the filter against the base plate of the housing. In the case of Radial Sealing air filter elements, the sealing is complete by pushing the molded rubber (polyurethane) open end over a short tube built into the base of the air cleaner body. The filter is retained by the housing cover sitting against the closed upper endplate.

What is the advantage of a Radial Sealing style air cleaner housing/filter elements compared to a more conventional air cleaner?

The major advantages of the Radial Sealing filters are the ease and speed of service. Generally, Radial Sealing air filter elements can be changed without needing to use tools. The air cleaner cover usually twists off or is removed by undoing "flip over" clips or catches, and the element is simply pulled off. Conventional housings often require wing nuts to be undone and, in some cases, a whole series of nuts has to be undone before the element can be removed.

Can I use a Radial Sealing air filter element in a standard (conventional) air cleaner housing?

No, the conventional air cleaner housings are not designed to create a complete seal with the Radial Sealing air filters.

Can I use a conventional secondary/inner air filter element with a Radial Sealing primary filter and vice versa?

No. Conventional primary/outer air filters have to be used with conventional secondary/inner elements and housings. Radial Sealing primary/outer air filters have to be used with Radial Sealing secondary/inner elements and housings.

What does Two-Stage/Dual-Stage Air Cleaner mean?

A two-stage air cleaner has a pre-cleaner integral to the system. Most heavy duty applications, the air cleaner will have a dust ejection valve. The majority of the heavy dust particles are removed from the air cleaner by this valve (stage 1). The remaining dust is then removed from the air by the primary filter element (stage 2).

For a two-stage air cleaner, does the orientation of the dust ejection valve make a difference?

Yes. The dust ejection valve must be pointed within 15° of straight down to have proper pre-cleaning abilities.

What is the Radial Sealing Type air filter element?



Service and Maintenance Tips

Does it matter if the Dust Ejection Valve is cracked, torn, or remains open?

Yes. The dust ejection valve does not work as efficiently if it is not in good condition, which can reduce the efficiency of the pre-cleaner as it shortens its service life. Replace cracked, torn or otherwise damaged dust ejection valves for optimal performance.

Are OptiAir™ filter elements interchangeable with Radial Sealing filter elements?

No. Although the sealing on both styles of products is done radially, the sealing surface on the OptiAir products is located at a larger outer diameter for similar sizes of air housings.

What information is required to select a Fleetguard pre-cleaner™ ?

You will need to know the air flow rate (m³/min or CFM). If you are not sure of the engine air flow rate, please contact your Fleetguard distributor for further information. Do not size by the diameter of the intake piping.

If the Fleetguard pre-cleaner outlet size does not match the air cleaner intake diameter, what do I do?

There is a range of adapter kits available to convert the pre-cleaner to the size required.

How fast does the rotor of a Fleetguard pre-cleaner spin, and are the bearings shielded or sealed?

The rotor spins at about 3000 RPM on average and the bearings are sealed with an O-Ring to prevent contamination.

Does the top cap of a Fleetguard pre-cleaner come off for repairs? What maintenance is required?

No, there are no serviceable components inside the Fleetguard pre-cleaner. These units are self-cleaning ejective pre-cleaners that eject the contaminant they remove. They are maintenance free. Fleetguard pre-cleaners are covered by a two year unlimited hours warranty.

At what height should a Fleetguard pre-cleaner be mounted?

It should not be mounted flush against any part of the machine because space is needed beneath the unit to allow the air to enter.

What is a Fleetguard pre-cleaner made of?

They are manufactured from an engineering polymer that is more durable, lighter, and less expensive than any metal product.

Should I play it safe and go to the next size (higher flow rate) up when selecting a Fleetguard pre-cleaner unit?

No. These units work most efficiently within their stated flow range. Selecting an "oversized" unit can result in a lower pre-cleaning efficiency due to lower turbine speed. Select a pre-cleaner where the added initial restriction stays within acceptable limits to obtain maximum service life.

Can the Fleetguard pre-cleaner units be mounted vertically as

well as horizontally?

Yes, these units can be mounted at any angle up to 90° from the horizontal.

Should I pay attention to the orientation of the Fleetguard pre-cleaner dust ejector slot during installation on the equipment?

Yes. For mobile equipment, make sure the ejector slot is oriented opposed to the most common driving direction. In cases where the Fleetguard pre-cleaner is not installed vertically, be sure that the ejector slot is oriented downward, as water may enter the air intake system. Where more than one unit is installed, make sure none of the units are expelling at each other. Also, face slots in the direction of the prevailing wind to avoid expelled air blowing back at the unit.

The main reason for washing heavy duty air filter cartridges is to reduce the overall cost of filtration. However, this is often not the end result. Several studies have been conducted over the past few years, all with the similar conclusions, as follows:

Cleaning air filters reduces the dust holding capacity compared to a new filter. Dust holding capacity can drop by up to 25% after the first cleaning, with additional capacity loss after each subsequent cleaning. Loss of dust capacity shortens the usable service life of the filter, which leads to more frequent service – which in turn adds additional risk of mis-service and/or accidental dust ingress.

The air filter media can be weakened as a result of cleaning, which could cause ruptures. Even the smallest rupture will cause the filter to be less efficient and may allow enough dust into your engine/equipment to cause serious damage, downtime, and rebuilds.

On-highway air filters should not be cleaned since the contamination encountered over the road (fine particles and soot material) is very difficult to remove from the air filter media.

Secondary air filters should never be cleaned since the secondary element is the last barrier to contaminants before they reach your engine.

Standard leak testing (light bulb) is not always conclusive in detecting faults in pleated filter elements.

“Inside-out” washers are often used to wash opposite flow filters, actually bringing impurities to the clean air side of the filter during the washing process.

The filter assembly and/or gaskets can be damaged in the washing process.

A new, quality filter is about 99.9% efficient over its lifetime. A cleaned filter with an efficiency of 95% would actually allow 50 times more dirt to pass through to the engine than a typical good filter.

However, if you decide to clean your air filters, remember that there are a few risks. **Do-it-yourself cleaning techniques and improvised cleaning tools offer considerable risk to the air filter integrity and should be avoided.** Commercially available air filter cleaning services are most likely to be better equipped and have more reliable techniques for cleaning air filters than most maintenance shops.

Select a reputable commercial cleaning service that uses cleaning and handling practices proven to be effective for your filters and applications. It is recommended that this business offer a warranty for the cleaned filter, since Cummins Filtration® and most other air filter manufacturers, will not warrant a cleaned air filter.

Glossary of Terms

AA – Prefix denoting a Dual Pack Air Kit which is usually a package of two air filter elements in the Fleetguard® product line.

AF – Prefix denoting an Air Filter within the Fleetguard product line.

AH – Prefix denoting an Air Housing within the Fleetguard product line.

AK – Prefix denoting an Air Kit within the Fleetguard product line.

AS – Prefix denoting an Air Oil Separator Filter within the Fleetguard product line.

AP – Prefix denoting an Air Pre-cleaner unit within the Fleetguard product range.

Air Cleaner (Housing) – The assembly consisting of a housing usually made from metal or polymer/plastic containing one or more air filter elements to clean the air going into an engine.

CFM (ft³/min) – Volume of air flow expressed in cubic feet per minute.
1 ft³/min = 0.02831685 m³/min

Dual Stage Air Cleaner/ 2-Stage – An air cleaner where a pre-cleaner removes most of the contaminant before it reaches the primary filter. The primary filter is then the second means of contaminant removal.

Dust Ejection/Unloader Valve – A rubber valve that allows contaminant removed by the pre-cleaner stage to be removed from the air cleaner body.

Efficiency – The ability of an air cleaner/element to remove contaminant from the incoming air flow.

Heavy Duty – A two stage air cleaner/filter with a pre-cleaner and a secondary element. Typical applications would be construction, mining and agricultural equipment in a heavy dust environment.

ISO – International Standards Organization, the body that publishes many standards and oversees many of the national standards setting organizations around the World such as AFNOR, BSI, ANSI, etc.

ISO Ultra Fine – Very fine grade test dust used for special cases where an engine is consistently exposed to very small particles.

ISO Fine – Fine grade test dust generally used for single stage air cleaner evaluation.

ISO Medium – Medium grade test dust which is rarely used.

ISO Coarse – Coarse grade test dust generally used for dual stage air cleaner evaluation.

Initial Restriction – The resistance created by the air cleaner/filter element(s) to the air flow required by the engine measured under steady state flow conditions with a clean element (Ref. ISO 5011).

Inner Filter/Element – See “Secondary Element/Filter.”

K – Suffix denoting an Air Filter within the Fleetguard product range which has pre-cleaning fins attached.

Light Duty – A single stage air cleaner/filter. Typical applications would be on-highway and stationary engine applications exposed to light dust conditions.

Life (Capacity) – Quantity of test dust removed by the air cleaner under test conditions with a terminal restriction of

25 in H₂O/6.23 kPa. Ref. ISO 5011.

M – Suffix denoting a Magnum Air Filter within the Fleetguard product line.

Magnum – An Air Filter element within the Fleetguard product line with pleated media to increase the filtration area and therefore increase the dirt holding capacity and filter service life.

Medium Duty – A two-stage air cleaner/filter with an inertial or centrifugal first stage. Typical applications would be light industrial, on/off-highway vehicles, etc. which are used occasionally in a heavy dust environment.

Minder Gauge – See “Restriction indicator.”

m³/min – Volume of air flow expressed in cubic meters per minute.
1 m³/min = 35.31467 CFM

Outer Filter/Element – See “Primary Element/Filter.”

Primary Element/Filter – The replaceable filter element which the contaminant reaches first and accumulates.

Rain Cap – See “Weather Hood.”

Restriction Indicator – Gauge used to monitor the service life of an air filter element. Gauge notifies user of terminal restriction when filter element should be changed.

Safety Filter/Element – See “Secondary Element/Filter.”

Secondary Element/Filter – A replaceable filter element that usually fits inside the primary filter element. Purpose is to prevent contaminant that may fall off the primary element from getting into the clean air

ducting when servicing the primary. A secondary element is generally less efficient than the corresponding primary and should typically be changed once for every 3-5 primary change-outs.

Single Stage Air Cleaner – An air cleaner (with no pre-cleaner) where the primary filter element removes all the contaminant from the intake air.

Spark Arrestor – Unit that is connected to the intake pipe in place of an intake filter. It's purpose is to prevent any sparks from exiting the intake in the case of a backfire situation. This product is used mostly on marine applications where intake contaminants are of little concern, but fire is an ongoing risk.

Terminal Restriction – The maximum restriction across the air cleaner/filter element(s) recommended by the engine manufacturer, usually 5.0 - 6.2 kPa (20 to 25") water gauge.

Test Dust – Contaminant used under laboratory conditions to evaluate the performance of an air cleaner and filter assembly in terms of particle removal efficiency and filter life. These are “calibrated” test dusts where the chemical composition and particle size distribution is very carefully controlled and are available in different grades (see “ISO”).

Clean-Air Duct (Trunking) – the tube which connects the air intake to the air cleaner body and the air cleaner body to the engine.

Weather Hood – Cover or cowl to prevent rain and large debris from entering the air intake system.

Revisions

Revision	Date	Description
A	05-21-2018	Added Revision Block, LT36500 was LT32599
B	10-25-2019	Added Direct Flow Sections DF200, DF390, DF585, DF1800 and DF2100 Added Pre-Cleaners, Maintenance Free and Radial Fin Added Filter Efficiency specifications to Air Cleaners
C	01-13-2020	Updated charts for Air Intake Components: Reducing 90° Elbows, 90° Elbows, Reducing 45° Elbows, 45° Elbows, and Reducer Inlet Sleeves. Corrected Letter references on graphics for 45° and 90° Rubber Reducing Elbows
D	03-24-2020	AK55695 said AH55695 in ordering section. DF390 section of DF Selection Chart said DF900. Fixed these typos.
E	06-02-2020	Corrected DF 1800 graph, Discontinued part 3316633 S Inlet Sleeve Reducer

Revisions